

Perturbative renormalization factors of bilinear quark operators for improved gluon and quark actions in lattice QCD

Sinya Aoki,^{1,2} Kei-ichi Nagai,³ Yusuke Taniguchi,¹ and Akira Ukawa¹

¹*Institute of Physics, University of Tsukuba, Tsukuba, Ibaraki-305, Japan*

²*Max-Planck-Institut für Physik, Föhringer Ring 6, D-80805 München, Germany*

³*Center for Computational Physics, University of Tsukuba, Tsukuba, Ibaraki-305, Japan*

(Received 2 March 1998; published 2 September 1998)

We calculate one-loop renormalization factors of bilinear quark operators for the gluon action including six-link loops and an $O(a)$ -improved quark action in the limit of a massless quark. We find that finite parts of the one-loop coefficients of renormalization factors diminish monotonically as either of the coefficients c_1 or $c_2 + c_3$ of the six-link terms is decreased below zero. Detailed numerical results are given, for general values of the clover coefficient, for the tree-level improved gluon action in the Symanzik approach ($c_1 = -1/12, c_2 = c_3 = 0$) and for the choices suggested by Wilson ($c_1 = -0.252, c_2 = 0, c_3 = -0.17$) and by Iwasaki ($c_1 = -0.331, c_2 = c_3 = 0$ and $c_1 = -0.27, c_2 + c_3 = -0.04$) from renormalization-group analyses. Compared with the case of the standard plaquette gluon action, the finite parts of the one-loop coefficients are reduced by 10–20 % for the Symanzik action, and approximately by a factor of 2 for the renormalization-group improved gluon actions. [S0556-2821(98)04517-2]

PACS number(s): 11.15.Ha, 12.38.Aw, 12.38.Bx, 12.38.Gc

I. INTRODUCTION

Lattice QCD calculations of hadron matrix elements require values of renormalization factors which relate operators on the lattice to those in the continuum. For the standard plaquette gluon action, the perturbative calculation of renormalization factors for a massless quark has been carried out to one-loop order for bilinear and four-quark operators, both for the Wilson quark action [1–6] and for the $O(a)$ -improved ‘‘clover’’ action [7–14] originally suggested by Sheikholeslami and Wohlert [15,16]. With development of our full QCD simulations [17] employing an improved gluon action [18], we find it necessary to extend these calculations. In this article we report results for renormalization factors of bilinear quark operators at the one-loop level for the gluon action improved by the addition of six-link loops to the plaquette term. For the quark action we treat both the Wilson and $O(a)$ -improved actions, taking the limit of a massless quark. We evaluate numerical values of the one-loop coefficients of renormalization factors for the case of the tree-level improved action in the Symanzik approach [19,20] and for several cases of renormalization-group improved actions [18,21]. We also examine how the one-loop coefficients vary for general values of the coefficients of the six-link loop terms.

In Sec. II we write down the action we treat and the Feynman rules to fix our conventions. The structure of renormalization factors related to the fermion self-energy is discussed in Sec. III and that for bilinear quark operators in Sec. VI. Numerical results for one-loop coefficients are given in Sec. V. Since the procedure of calculation is by now standard, we shall be brief on this point. Expressions for one-loop integrands are listed in Appendix A. In Appendix B we collect one-loop results for the relation between the renormalized and bare coupling constants for various choices of gluon and quark actions.

II. ACTION AND FEYNMAN RULES

The gluon action we consider is defined by

$$S_{\text{gluon}} = \frac{1}{g^2} \left\{ c_0 \sum_{\text{plaquette}} \text{Tr} U_{pl} + c_1 \sum_{\text{rectangle}} \text{Tr} U_{rtg} + c_2 \sum_{\text{chair}} \text{Tr} U_{chr} + c_3 \sum_{\text{parallelogram}} \text{Tr} U_{plg} \right\}, \quad (1)$$

where the first term represents the standard plaquette term, and the remaining terms are six-link loops formed by a 1×2 rectangle, a bent 1×2 rectangle (chair), and a three-dimensional parallelogram. The coefficients c_0, \dots, c_3 satisfy the normalization condition

$$c_0 + 8c_1 + 16c_2 + 8c_3 = 1. \quad (2)$$

For the quark action we consider

$$S_{\text{quark}} = S_W + S_C, \quad (3)$$

where S_W is the Wilson action given by

$$S_W = a^3 \sum_n \frac{1}{2} \sum_{\mu} [\bar{\psi}_n(-r + \gamma_{\mu}) U_{n,\mu} \psi_{n+\hat{\mu}} + \bar{\psi}_n(-r - \gamma_{\mu}) U_{n-\mu,\mu}^{\dagger} \psi_{n-\hat{\mu}}] + (am_0 + 4r) \bar{\psi}_n \psi_n, \quad (4)$$

with a the lattice spacing, and S_C represents the ‘‘clover’’ term defined by

$$S_C = -c_{\text{SW}} a^3 \sum_n \sum_{\mu,\nu} i g \frac{r}{4} \bar{\psi}_n \sigma_{\mu\nu} P_{\mu\nu}(n) \psi_n. \quad (5)$$

For the field strength $P_{\mu\nu}$ we adopt the definition given by

$$P_{\mu\nu}(n) = \frac{1}{4} \sum_{i=1}^4 \frac{1}{2ig} [U_i(n) - U_i^\dagger(n)], \quad (6)$$

$$U_1(n) = U_{n,\mu} U_{n+\hat{\mu},\nu} U_{n+\hat{\nu},\mu}^\dagger U_{n,\nu}^\dagger, \quad (7)$$

$$U_2(n) = U_{n,\nu} U_{n-\hat{\mu}+\hat{\nu},\mu}^\dagger U_{n-\hat{\mu},\nu}^\dagger U_{n-\hat{\mu},\mu}, \quad (8)$$

$$U_3(n) = U_{n-\hat{\mu},\mu}^\dagger U_{n-\hat{\mu}-\hat{\nu},\nu}^\dagger U_{n-\hat{\mu}-\hat{\nu},\mu} U_{n-\hat{\nu},\nu}, \quad (9)$$

$$U_4(n) = U_{n-\hat{\nu},\nu}^\dagger U_{n-\hat{\nu},\mu} U_{n+\hat{\mu}-\hat{\nu},\nu} U_{n,\mu}^\dagger. \quad (10)$$

Our γ matrix convention is as follows:

$$\gamma_i = \begin{pmatrix} 0 & -i\sigma^i \\ i\sigma^i & 0 \end{pmatrix}, \quad \gamma_4 = \begin{pmatrix} 0 & 1 \\ 1 & 0 \end{pmatrix}, \quad (11)$$

$$\gamma_5 \equiv \gamma_1 \gamma_2 \gamma_3 \gamma_4 = \begin{pmatrix} 1 & 0 \\ 0 & -1 \end{pmatrix}, \quad (12)$$

$$\sigma_{\mu\nu} = \frac{1}{2} [\gamma_\mu, \gamma_\nu]. \quad (13)$$

Weak-coupling perturbation theory is developed by writing

$$U_{n,\mu} = \exp \left[ig a A_\mu \left(n + \frac{1}{2} \hat{\mu} \right) \right]. \quad (14)$$

We adopt a covariant gauge fixing with a gauge parameter α defined by

$$S_{\text{GF}} = a^4 \sum_n \frac{1}{2\alpha} \left[\nabla_\mu A_\mu^a \left(n + \frac{1}{2} \hat{\mu} \right) \right]^2, \quad (15)$$

where $\nabla_\mu f_n \equiv (f_{n+\hat{\mu}} - f_n)/a$. The free part of the gluon action takes the form

$$S_{\text{gluon}} = \frac{1}{2} \int_{-\pi/a}^{+\pi/a} \frac{d^4 k}{(2\pi)^4} \sum_{\mu,\nu} A_\mu^a(k) G_{\mu\nu} A_\nu^a(-k), \quad (16)$$

where

$$G_{\mu\nu} = \hat{k}_\mu \hat{k}_\nu + \sum_p (\hat{k}_p \delta_{\mu\nu} - \hat{k}_\mu \delta_{p\nu}) q_{\mu p} \hat{k}_p, \quad (17)$$

with

$$\hat{k}_\mu = \frac{2}{a} \sin \frac{k_\mu a}{2} \quad (18)$$

and $q_{\mu\nu}$ is defined as

$$q_{\mu\nu} = (1 - \delta_{\mu\nu}) [1 - (c_1 - c_2 - c_3) a^2 (\hat{k}_\mu^2 + \hat{k}_\nu^2) - (c_2 + c_3) a^2 \hat{k}^2]. \quad (19)$$

The gluon propagator can be written as

$$D_{\mu\nu} = (\hat{k}^2)^{-2} \left[\hat{k}_\mu \hat{k}_\nu + \sum_\sigma (\hat{k}_\sigma \delta_{\mu\nu} - \hat{k}_\nu \delta_{\mu\sigma}) \hat{k}_\sigma A_{\sigma\nu} \right] - (1 - \alpha) \frac{\hat{k}_\mu \hat{k}_\nu}{(\hat{k}^2)^2} \quad (20)$$

$$= (\hat{k}^2)^{-2} \left[(1 - A_{\mu\nu}) \hat{k}_\mu \hat{k}_\nu + \delta_{\mu\nu} \sum_\sigma \hat{k}_\sigma^2 A_{\nu\sigma} \right] - (1 - \alpha) \frac{\hat{k}_\mu \hat{k}_\nu}{(\hat{k}^2)^2}, \quad (21)$$

where $A_{\mu\nu}$ is a function of $q_{\mu\nu}$ and \hat{k}_μ whose form we refer to the original literature [18,19].

The free quark propagator is given by

$$S_q(p) = \frac{-i \sum_\mu \gamma_\mu \bar{p}_\mu + W(p)}{\sum_\mu \bar{p}_\mu^2 + W(p)^2}, \quad (22)$$

where

$$\bar{k}_\mu = \frac{1}{a} \sin k_\mu a, \quad (23)$$

$$W(p) = m + \frac{r}{a} \sum_\mu (1 - \cos ap_\mu). \quad (24)$$

To calculate renormalization factors of bilinear quark operators to one-loop order, we need only one- and two-gluon vertices with quarks. The vertices originating from the Wilson quark action are given by

$$V_{1\mu}^a(k,p) = -ig T^a \left\{ \gamma_\mu \cos \frac{a}{2} (-k_\mu + p_\mu) - ir \sin \frac{a}{2} (-k_\mu + p_\mu) \right\}, \quad (25)$$

$$V_{2\mu\nu}^{ab}(k,p) = \frac{a}{2} g^2 \frac{1}{2} \{ T^a, T^b \} \left\{ i \gamma_\mu \sin \frac{a}{2} (-k_\mu + p_\mu) - r \cos \frac{a}{2} (-k_\mu + p_\mu) \right\} \delta_{\mu\nu}, \quad (26)$$

and the interaction due to the clover term has the form

$$V_{\text{C1}\mu}^a(k,p) = -c_{\text{sw}} g \frac{r}{2} \left(\sum_\nu \sigma_{\mu\nu} \sin a(p_\nu + k_\nu) \right) \times \cos \frac{a}{2} (p_\mu + k_\mu) T^a. \quad (27)$$

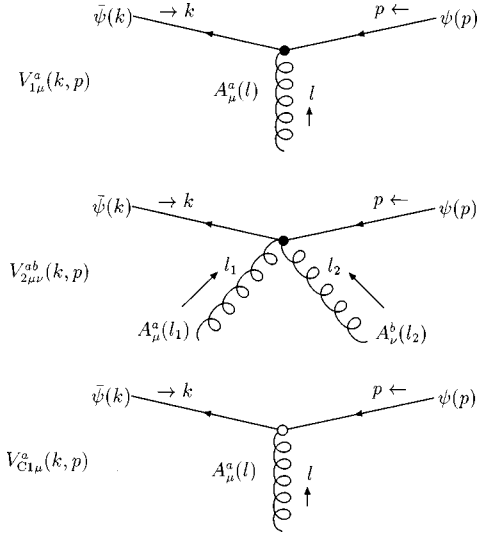

FIG. 1. Quark-gluon vertices needed for our one-loop calculations.

Our momentum assignments for the vertices are depicted in Fig. 1. The two-gluon vertex with quarks from the clover term gives no contribution to diagrams we evaluate, and is hence omitted.

III. QUARK SELF-ENERGY

Let us write the inverse full quark propagator as

$$S_q^{-1}(p) = i\gamma_\mu \bar{p}_\mu + W(p) - \Sigma(p). \quad (28)$$

Calculating the quark self-energy $\Sigma(p)$ to one-loop order on the lattice and making an expansion of form

$$\Sigma(p) = \Sigma(0) + \frac{\partial \Sigma(0)}{\partial p_\mu} p_\mu + O(p^2), \quad (29)$$

we find

$$\begin{aligned} S_q^{-1}(p) = i\gamma_\mu p_\mu \left[1 - \frac{g^2}{16\pi^2} C_F \{ \log(\lambda a)^2 + \Sigma_1 \right. \\ \left. + (\alpha - 1)[\log(\lambda a)^2 + \Sigma_\alpha] \right] \\ + m \left[1 - \frac{g^2}{16\pi^2} C_F \{ 4 \log(\lambda a)^2 + \Sigma_2 \right. \\ \left. + (\alpha - 1)[\log(\lambda a)^2 + \Sigma_\alpha] \right], \quad (30) \end{aligned}$$

where

$$m = m_0 - \frac{g^2}{16\pi^2} C_F \frac{\Sigma_0}{a}. \quad (31)$$

In Eq. (30) the coefficients of $i\gamma_\mu p_\mu$ and m are evaluated with $m_0 = 0$. The infrared divergence that appears in this case is regularized by a gluon mass λ introduced in the gluon propagator as described in Appendix A. Of the finite constants $\Sigma_i (i=0,1,2,\alpha)$, Σ_α is independent of the clover coefficient c_{SW} ; nor does it depend on the improved part of the gluon action. The other constants $\Sigma_i (i=0,1,2)$ depend quadratically on the clover coefficient c_{SW} , and we write

$$\Sigma_i = \Sigma_i^{(0)} + c_{SW} \Sigma_i^{(1)} + c_{SW}^2 \Sigma_i^{(2)}. \quad (32)$$

Let us recall that the hopping parameter K is related to the bare quark mass m_0 through

$$K = \frac{1}{2(m_0 a + 4)}. \quad (33)$$

The critical hopping parameter corresponding to a massless quark is given by

$$K_c = \frac{1}{8} \left(1 - \frac{g^2}{16\pi^2} C_F \frac{\Sigma_0}{4} \right). \quad (34)$$

In the continuum we employ the modified minimal subtraction $\overline{\text{MS}}$ scheme with naive dimensional regularization. The one-loop self-energy in the continuum has the same form as Eq. (30) with, however, the replacements

$$\log(\lambda a)^2 \rightarrow \log(\lambda/\mu)^2, \quad (35)$$

$$\Sigma_1 \rightarrow \Sigma_1^{\overline{\text{MS}}} = 1/2, \quad (36)$$

$$\Sigma_2 \rightarrow \Sigma_2^{\overline{\text{MS}}} = -2, \quad (37)$$

$$\Sigma_\alpha \rightarrow \Sigma_\alpha^{\overline{\text{MS}}} = -1. \quad (38)$$

Let us define the quark wave function renormalization factor needed for converting the lattice field to the continuum field in the $\overline{\text{MS}}$ scheme by

$$\psi^{\overline{\text{MS}}} = \sqrt{Z_\psi} \psi^{lat}. \quad (39)$$

To one-loop order we then find that

$$\begin{aligned} Z_\psi(\mu a) = 1 + \frac{g^2}{16\pi^2} C_F \{ -\log(\mu a)^2 + z_\psi \\ + (\alpha - 1)[-\log(\mu a)^2] \}, \quad (40) \end{aligned}$$

where

$$z_\psi = \Sigma_1^{\overline{\text{MS}}} - \Sigma_1 + (\alpha - 1)(\Sigma_\alpha^{\overline{\text{MS}}} - \Sigma_\alpha). \quad (41)$$

The quark mass renormalization factor defined by

$$m^{\overline{\text{MS}}}(\mu) = Z_m(\mu a) m \quad (42)$$

is given by

$$Z_m(\mu a) = 1 + \frac{g^2}{16\pi^2} C_F [-3 \log(\mu a)^2 + z_m], \quad (43)$$

with

$$z_m = (\Sigma_2^{\overline{\text{MS}}} - \Sigma_2) - (\Sigma_1^{\overline{\text{MS}}} - \Sigma_1). \quad (44)$$

It is worth noting that the critical hopping parameter K_c and the quark mass renormalization factor Z_m do not depend on the gauge parameter α .

IV. BILINEAR OPERATORS

We consider bilinear quark operators in the following form [10]:

$$O_\Gamma(z) = [1 + ram_0(1-z)] \bar{\psi} \Gamma \psi + z \bar{\psi} \Gamma^\otimes \psi - z^2 \bar{\psi} \Gamma' \psi. \quad (45)$$

Here Γ denotes the appropriate γ matrices, and the additional operators in the second and the third terms needed for improvement are defined by

$$\begin{aligned} \bar{\psi} \Gamma^\otimes \psi \equiv & \frac{r}{4} [(\bar{\psi}_{n+\mu} U_{n,\mu}^\dagger - \bar{\psi}_{n-\mu} U_{n-\mu,\mu}) \gamma_\mu \Gamma \psi_n \\ & - \bar{\psi}_n \Gamma \gamma_\mu (U_{n,\mu} \psi_{n+\mu} - U_{n-\mu,\mu}^\dagger \psi_{n-\mu})], \quad (46) \end{aligned}$$

$$\begin{aligned} \bar{\psi} \Gamma' \psi \equiv & \frac{r^2}{16} [(\bar{\psi}_{n+\mu} U_{n,\mu}^\dagger - \bar{\psi}_{n-\mu} U_{n-\mu,\mu}) \\ & \times \gamma_\mu \Gamma \gamma_\nu (U_{n,\nu} \psi_{n+\nu} - U_{n-\nu,\nu}^\dagger \psi_{n-\nu})]. \quad (47) \end{aligned}$$

At one-loop order, on-shell matrix elements of $O_\Gamma(z)$ do not have terms of $O(a)$ or $O(g^2 a \log a)$ [16]. To remove terms of $O(g^2 a)$, the coefficients of the added operators as well as that of am_0 in Eq. (45) have to be corrected by an $O(g^2)$ term. For vector and axial vector currents, an addition of a total derivative operator with an $O(g^2)$ coefficient is also necessary [13]. Evaluating these coefficients is outside the scope of this article.

We calculate the renormalization factor of $O_\Gamma(z)$ for a massless quark. The on-shell vertex functions for the three operators in Eq. (45), for a quark and an antiquark with momenta $p=p'=0$ as external states, take the form

$$T_\Gamma = \left[1 + \frac{g^2 C_F}{16\pi^2} \left\{ -\frac{h_2(\Gamma)}{4} \log(\lambda a)^2 + V_\Gamma + (\alpha - 1) [-\log(\lambda a)^2 + V_\alpha] \right\} \right] \Gamma \quad (48)$$

$$T_{\Gamma^\otimes} = \frac{g^2 C_F}{16\pi^2} V_{\Gamma^\otimes} \Gamma, \quad (49)$$

$$T_{\Gamma'} = \frac{g^2 C_F}{16\pi^2} V_{\Gamma'} \Gamma, \quad (50)$$

where λ is the gluon mass, and $h_2(\Gamma)$ is an integer given by

$$h_2(\Gamma) = 4(A), 4(V), 16(P), 16(S), 0(T) \quad (51)$$

for various Dirac channels. The finite constants V_i ($i = \Gamma, \Gamma^\otimes, \Gamma'$) depend quadratically on the clover coefficients c_{SW} , and we write

$$V_\Gamma = V_\Gamma^{(0)} + c_{SW} V_\Gamma^{(1)} + c_{SW}^2 V_\Gamma^{(2)}, \quad (52)$$

$$V_{\Gamma^\otimes} = V_{\Gamma^\otimes}^{(0)} + c_{SW} V_{\Gamma^\otimes}^{(1)} + c_{SW}^2 V_{\Gamma^\otimes}^{(2)}, \quad (53)$$

$$V_{\Gamma'} = V_{\Gamma'}^{(0)} + c_{SW} V_{\Gamma'}^{(1)} + c_{SW}^2 V_{\Gamma'}^{(2)}. \quad (54)$$

The constant V_α satisfies $V_\alpha = -\Sigma_\alpha$.

In the continuum, the on-shell vertex function to one-loop order is given in the $\overline{\text{MS}}$ scheme by

$$T_\Gamma^{\overline{\text{MS}}} = \left[1 + \frac{g^2 C_F}{16\pi^2} \left\{ \frac{h_2(\Gamma)}{4} \log(\mu/\lambda)^2 + V_\Gamma^{\overline{\text{MS}}} + (\alpha - 1) [\log(\mu/\lambda)^2 + 1] \right\} \right] \Gamma, \quad (55)$$

with

$$V_\Gamma^{\overline{\text{MS}}} = \frac{3h_2(\Gamma)}{8} + j(\Gamma), \quad (56)$$

where

$$j(\Gamma) = -2(-6)(A), -2(-2)(V), -4(4)(P), -4(-4)(S), 0(0)(T) \quad (57)$$

for the anticommuting and 't Hooft–Veltman definition of γ_5 , with values for the latter in parentheses.

Combining the above results and including self-energy corrections, the relation between the continuum operator in

the $\overline{\text{MS}}$ scheme and the lattice operator is given by

$$O_\Gamma^{\overline{\text{MS}}}(\mu) = Z_\Gamma \{ [1 + ram_0 a(1-z)] \bar{\psi} \Gamma \psi + z \bar{\psi} \Gamma^\otimes \psi - z^2 \bar{\psi} \Gamma' \psi \}, \quad (58)$$

TABLE I. Finite constants for the quark self-energy. Coefficients of the term $c_{SW}^n (n=0,1,2)$ are given in the column marked as (n) . Tadpole contributions are also listed.

Gauge action		Σ_0					Σ_1			Σ_2		Σ_α	
c_1	c_{23}	(0)	tad	(1)	(2)	(0)	tad	(1)	(2)	(0)	(1)	(2)	
0	0	-51.435	-48.932	13.733	5.715	13.352	12.233	-2.249	-1.397	-2.100	-9.987	-0.017	-4.793
-1/12	0	-40.444	-40.518	11.948	4.663	9.731	10.130	-2.015	-1.242	-2.376	-8.851	0.125	
-0.331	0	-26.073	-29.928	9.015	3.106	4.825	7.482	-1.601	-0.973	-2.533	-6.902	0.293	
-0.27	-0.04	-27.214	-30.754	9.283	3.219	5.208	7.689	-1.644	-1.005	-2.552	-7.098	0.287	
-0.252	-0.17	-24.688	-28.937	8.698	2.884	4.294	7.234	-1.566	-0.963	-2.572	-6.731	0.324	
$\overline{\text{MS}}$		0	-	-	-	1/2	-	-	-	-2	-	-	-1

where

$$Z_\Gamma = 1 + \frac{g^2 C_F}{16\pi^2} \left[\left(\frac{h_2(\Gamma)}{4} - 1 \right) \log(\mu a)^2 + z_\Gamma \right] \quad (59)$$

and

$$z_\Gamma = Z_\Gamma^{\overline{\text{MS}}} - Z_\Gamma^{\text{lat}}, \quad (60)$$

with

$$Z_\Gamma^{\overline{\text{MS}}} = \frac{3h_2(\Gamma)}{8} + j(\Gamma) + 1/2, \quad (61)$$

$$Z_\Gamma^{\text{lat}} = V_\Gamma + \Sigma_1 + (1-z)r\Sigma_0 + zV_{\Gamma^\otimes} - z^2V_{\Gamma'}, \quad (62)$$

For evaluating values of the renormalization factors, estimating the renormalized coupling constant for a given value of the bare coupling constant often becomes necessary. We collect the one-loop results needed for such an estimation for various choices of gluon and quark actions in Appendix B.

V. NUMERICAL RESULTS

A. Computational procedure

We calculate the renormalization factors of bilinear quark operators for a massless quark with the Wilson parameter $r = 1$. Two methods are employed to calculate the finite parts of lattice amplitudes. In the first method the Dirac algebra of Feynman integrands is carried out by hand, and the momentum integration is performed by a mode sum for a periodic box of size L^4 after transforming the momentum variable through $p_\mu = q_\mu - \sin q_\mu$. We employ the size $L=48$ for integrals which are infrared finite, and sizes up to $L=128$ for those whose infrared divergence is regularized by subtraction of the leading singular terms for small loop momenta. In the second method, a MATHEMATICA program is written to perform the Dirac algebra. The output is converted into a FORTRAN code, also by MATHEMATICA, and the momentum integration is carried out by the Monte Carlo routine VEGAS, using 10 samples of 50 000 points each. The agreement of results from the two methods is used as a check of our calculations. In Appendix A we list explicit forms of integrands, and explain how we regularize the infrared divergence.

B. Results for representative gluon actions

At the one-loop level, the choice of gluon action is specified by the pair of numbers c_1 and $c_{23} = c_2 + c_3$. As representative cases, we report numerical results for renormalization factors for (i) the tree-level improved action in the Symanzik approach $c_1 = -1/12, c_{23} = 0$ [19,20] and (ii) three choices suggested by an approximate renormalization-group analysis, $c_1 = -0.331, c_{23} = 0$ and $c_1 = -0.27, c_{23} = -0.04$ by Iwasaki [18] and $c_1 = -0.252, c_{23} = -0.17$ by Wilson [21]. We also include results for the standard plaquette action $c_1 = 0, c_{23} = 0$ to facilitate comparison with the cases above and also as a check of our results with those in the literature [1–3,8–12,22] with which we find good agreement using the same definition of the improved operator and renormalization scheme.

Since one-loop renormalization factors are quadratic polynomials in the clover coefficient c_{SW} , we tabulate results for the coefficients of the polynomial.

In Table I we list the finite constants for the quark self-energy for the choices of gluon action described above. The contribution of the tadpole diagram is also listed for Σ_0 and Σ_1 . Errors from numerical integration are at most in the last digit. Combining values in this table, we find the finite part z_m for the quark mass renormalization factor, which is tabulated in Table II.

Results for finite parts for lattice bilinear operators are given in Tables III (V_Γ), IV (V_{Γ^\otimes}), and V ($V_{\Gamma'}$). For local operators [$z=0$ in Eqs. (45) and (58)], these values lead to the finite part z_Γ listed in Table VI where we adopt the anti-commuting definition for γ_5 .

TABLE II. Finite part z_m of the renormalization factor for the quark mass. Coefficients of the term $c_{SW}^n (n=0,1,2)$ are given in the column marked as (n) .

Gauge action		z_m		
c_1	c_{23}	(0)	(1)	(2)
0	0	12.953	7.738	-1.380
-1/12	0	9.607	6.835	-1.367
-0.331	0	4.858	5.301	-1.267
-0.27	-0.04	5.260	5.454	-1.292
-0.252	-0.17	4.366	5.166	-1.287

TABLE III. Finite part V_Γ for local operators. Coefficients of the term $c_{SW}^n (n=0,1,2)$ are given in the column marked as (n) . Terms proportional to c_{SW}^1 are zero for the pseudoscalar P . Values for the $\overline{\text{MS}}$ scheme are for anticommuting and 't Hooft–Veltman definition of γ_5 (the latter in parentheses).

Gauge action		V			A					
c_1	c_{23}	(0)	(1)	(2)	(0)	(1)	(2)			
0	0	7.265	-2.497	0.854	2.444	2.497	-0.854			
-1/12	0	6.872	-2.213	0.778	2.808	2.213	-0.778			
-0.331	0	6.275	-1.725	0.637	3.367	1.725	-0.637			
-0.27	-0.04	6.332	-1.775	0.652	3.315	1.775	-0.652			
-0.252	-0.17	6.231	-1.683	0.625	3.414	1.683	-0.625			
$\overline{\text{MS}}$		-1/2	-	-	-1/2	-	-			
		(-1/2)	-	-	(-9/2)	-	-			
Gauge action		S			P		T			
c_1	c_{23}	(0)	(1)	(2)	(0)	(2)	(0)	(1)	(2)	
0	0	2.100	9.987	0.017	11.743	3.433	4.166	-1.665	-0.575	
-1/12	0	2.376	8.851	-0.125	10.502	2.987	4.307	-1.475	-0.477	
-0.331	0	2.533	6.902	-0.293	8.348	2.254	4.615	-1.150	-0.327	
-0.27	-0.04	2.552	7.098	-0.287	8.584	2.321	4.575	-1.183	-0.339	
-0.252	-0.17	2.572	6.731	-0.324	8.208	2.175	4.633	-1.122	-0.309	
$\overline{\text{MS}}$		2	-	-	2	-	0	-	-	
		(2)	-	-	(10)	-	(0)	-	-	

Looking at numerical values in these tables we observe that the one-loop coefficients are reduced by 10–20 % for the tree-level Symanzik action compared to those for the plaquette action. The reduction of magnitude is enhanced to a factor of about 2 for the renormalization-group improved actions.

C. Dependence on c_1 and c_2+c_3

The results above lead to a natural question as to how renormalization factors vary on the (c_1, c_{23}) plane. To examine this point, we calculate the lattice part of the one-loop coefficients for $-1 \leq c_1, c_{23} \leq 0$ in steps of 0.05. Choosing the tree-level value $c_{SW}=1$ and adding the three terms of the quadratic polynomial in c_{SW} , we find the results plotted in Figs. 2–4. These plots show that the renormalization factors are monotonic functions of c_1 and c_{23} , becoming smaller as either c_1 or c_{23} is decreased below zero.

TABLE IV. Finite part V_{Γ^\otimes} for improved operators. Coefficients of the term $c_{SW}^n (n=0,1,2)$ are given in the column marked as (n) . Values for the pseudoscalar P are zero.

Gauge action		V			A			S			T		
c_1	c_{23}	(0)	(1)	(2)	(0)	(1)	(2)	(0)	(1)	(2)	(0)	(1)	(2)
0	0	-9.786	3.416	0.885	-19.372	10.317	-0.885	-19.172	13.801	-3.538	-16.244	6.855	0.590
-1/12	0	-8.234	3.112	0.756	-15.852	8.836	-0.756	-15.235	11.448	-3.025	-13.518	6.058	0.504
-0.331	0	-5.881	2.547	0.546	-10.741	6.468	-0.546	-9.720	7.842	-2.183	-9.461	4.703	0.364
-0.27	-0.04	-6.085	2.608	0.564	-11.156	6.675	-0.564	-10.143	8.135	-2.257	-9.804	4.833	0.376
-0.252	-0.17	-5.640	2.498	0.521	-10.189	6.200	-0.521	-9.098	7.403	-2.084	-9.036	4.565	0.347

ACKNOWLEDGMENTS

Part of the numerical calculations for the present work has been carried out at Center for Computational Physics, University of Tsukuba. S.A. thanks Dr. S. Sint for providing us with his unpublished report. This work was supported in part by Grants-in-Aid for Scientific Research from the Ministry of Education, Science and Culture (Nos. 2373, 08640349, 08640350, 09246206). Y.T. was supported by the Japan Society for the Promotion of Science.

APPENDIX A

In this appendix we list explicit forms of the one-loop integrands for the quark self-energy and vertex functions. The lattice spacing is set $a=1$ for simplicity.

We first consider the quark self-energy. Using the same notation as in the main text we find

TABLE V. Finite part $V_{\Gamma'}$ for improved operators. Coefficients of the term $c_{SW}^n(n=0,1,2)$ are given in the column marked as (n) .

Gauge action		V			A		
c_1	c_{23}	(0)	(1)	(2)	(0)	(1)	(2)
0	0	-3.525	1.973	-0.412	3.296	-1.973	0.412
-1/12	0	-2.717	1.575	-0.338	2.549	-1.575	0.338
-0.331	0	-1.646	1.007	-0.225	1.552	-1.007	0.225
-0.27	-0.04	-1.715	1.045	-0.233	1.613	-1.045	0.233
-0.252	-0.17	-1.496	0.921	-0.209	1.402	-0.921	0.209

Gauge action		S			P		T			
c_1	c_{23}	(0)	(1)	(2)	(0)	(1)	(2)	(0)	(1)	(2)
0	0	4.981	-2.177	0.288	-8.660	5.715	-1.361	0.461	-0.590	0.179
-1/12	0	3.751	-1.638	0.205	-6.780	4.663	-1.145	0.393	-0.504	0.157
-0.331	0	2.171	-0.923	0.097	-4.225	3.106	-0.804	0.280	-0.364	0.118
-0.27	-0.04	2.260	-0.962	0.102	-4.396	3.219	-0.831	0.288	-0.376	0.121
-0.252	-0.17	1.925	-0.801	0.078	-3.870	2.884	-0.758	0.261	-0.347	0.113

$$\Sigma_0^{(n)} = -16\pi^2 \left[4rT\delta_{n,0} + \int \frac{1}{F_0} I_0^{(n)} \frac{1}{G_0} \right]$$

$$T = \int \frac{\sum_{\nu} \hat{k}_{\nu}^2 \bar{A}_{\mu\nu}}{2G_0},$$

for $n=0, 1, 2$, where

$$\int = \int_{-\pi}^{\pi} \frac{d^4k}{(2\pi)^4}, \quad G_0 = (\hat{k}^2)^2,$$

$$F_0 = \sum_{\nu} \sin^2 k_{\nu} + M^2, \quad W = r \sum_{\nu} (1 - \cos k_{\nu}).$$

Here T represents the tadpole integral for the improved action, which is given by

where $\bar{A}_{\mu\nu} = \delta_{\mu\nu} + A_{\mu\nu}$ with $A_{\mu\nu}$ as defined in the main text. The integrand $I_0^{(n)}$ is expressed as

$$I_0^{(0)} = -8r^3\Delta_1^3 - 16r\Delta_3\Delta_1 + 32r\Delta_1\Delta_{1,0}^{\mu},$$

$$I_0^{(1)} = 16\Delta_3^2 - 4\Delta_{1,1}^{\mu} - 16(4\Delta_3 - s_{\mu}^2)\Delta_{1,0}^{\mu},$$

$$I_0^{(2)} = \frac{r}{2}\Delta_1 I_0^{(1)},$$

where we define

TABLE VI. Finite part z_{Γ} of the renormalization factor for local bilinear quark operators [$z=0$ in Eqs. (45) and (58)]. Coefficients of the term $c_{SW}^n(n=0,1,2)$ are given in the column marked as (n) .

Gauge action		V			A		
c_1	c_{23}	(0)	(1)	(2)	(0)	(1)	(2)
0	0	30.817	-8.988	-5.172	35.638	-13.981	-3.464
-1/12	0	23.841	-7.720	-4.199	27.904	-12.146	-2.642
-0.331	0	14.974	-5.689	-2.770	17.881	-9.140	-1.496
-0.27	-0.04	15.674	-5.865	-2.866	18.691	-9.414	-1.562
-0.252	-0.17	14.163	-5.450	-2.546	16.981	-8.815	-1.297

Gauge action		S			P		T			
c_1	c_{23}	(0)	(1)	(2)	(0)	(1)	(2)	(0)	(1)	(2)
0	0	38.482	-21.471	-4.335	28.839	-11.484	-7.751	34.417	-9.820	-3.743
-1/12	0	30.837	-18.784	-3.296	22.710	-9.933	-6.408	26.905	-8.458	-2.944
-0.331	0	21.215	-14.316	-1.840	15.400	-7.414	-4.387	17.134	-6.264	-1.806
-0.27	-0.04	21.954	-14.737	-1.927	15.922	-7.639	-4.535	17.931	-6.456	-1.875
-0.252	-0.17	20.322	-13.864	-1.597	14.687	-7.133	-4.096	16.261	-6.011	-1.613

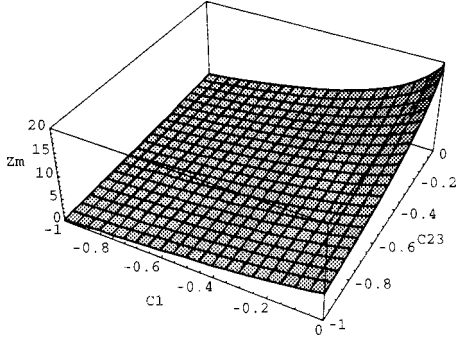

FIG. 2. Lattice finite part z_m for the quark mass renormalization factor as a function of c_1 and c_{23} for the clover quark action with $c_{SW}=1$.

$$s_\mu = \sin k_\mu, \quad c_\mu = \cos k_\mu, \quad c = \sum_\nu c_\nu,$$

$$\Delta_1 = \frac{1}{4} \hat{k}^2, \quad \Delta_3 = \frac{1}{4} \sum_\nu s_\nu^2, \quad \Delta_4 = \sum_\nu c_\nu s_\nu^2,$$

$$\Delta_{1,1}^\mu = \sum_\nu \bar{A}_{\mu\nu} s_\mu^2 s_\nu^2, \quad \Delta_{1,0}^\mu = \sum_\nu \bar{A}_{\mu\nu} \cos^2 \frac{k_\mu}{2} \sin^2 \frac{k_\nu}{2}.$$

Note that no sum is taken over the index μ for $\Delta_{1,1}^\mu$ and $\Delta_{1,0}^\mu$. Similarly we find

$$\begin{aligned} \Sigma_2^{(n)} = & -16\pi^2 \int \left[\frac{1}{F_0} \left\{ I_2^{(n)} - \frac{4r\Delta_1 I_0^{(n)}}{F_0} \right\} \frac{1}{G_0} \right. \\ & \left. - \frac{4}{(k^2)^2} \theta(\pi^2 - k^2) \delta_{n,0} \right] - 4 \log \pi^2 \delta_{n,0}, \end{aligned}$$

where

$$I_2^{(0)} = -4r^2 \Delta_1^2 + 16\Delta_{1,0}^\mu, \quad I_2^{(1)} = 0, \quad I_2^{(2)} = \frac{I_0^{(1)}}{4},$$

and

$$\Sigma_\alpha = -16\pi^2 \int \left[\frac{1}{G_0} - \frac{1}{(k^2)^2} \theta(\pi^2 - k^2) \right] - \log \pi^2.$$

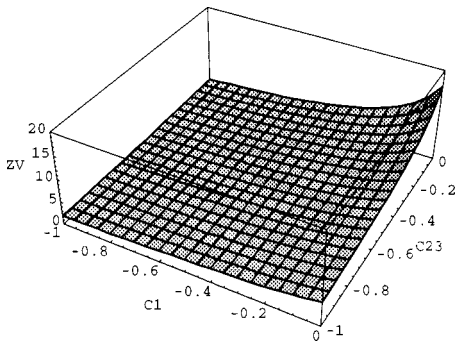

FIG. 3. Lattice finite part z_v for the vector current as a function of c_1 and c_{23} for the clover quark action with $c_{SW}=1$.

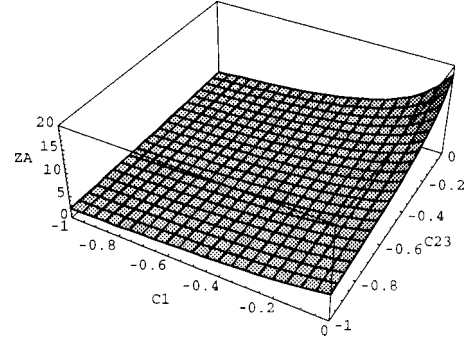

FIG. 4. Lattice finite part z_A for the axial vector current as a function of c_1 and c_{23} for the clover quark action with $c_{SW}=1$.

These formulas illustrate how we regularize the infrared divergence.

Finally we have

$$\begin{aligned} \Sigma_1^{(n)} = & 16\pi^2 T \delta_{n,0} - 16\pi^2 \int \left[\frac{1}{F_0} \left\{ I_1^{(n)} + \frac{J_1^{(n)}}{F_0} \right\} \frac{1}{G_0} \right. \\ & \left. - \frac{1}{(k^2)^2} \theta(\pi^2 - k^2) \delta_{n,0} \right] - \log \pi^2 \delta_{n,0}, \end{aligned}$$

where

$$I_1^{(0)} = 4\Delta_1 \Delta_3 + 4r^2 \Delta_1^3 + r^2 c \Delta_1^2 + 4(c - 4r^2 \Delta_1 - 2c_\mu) \Delta_{1,0}^\mu,$$

$$\begin{aligned} J_1^{(0)} = & (\Delta_4 + 8r^2 \Delta_1 \Delta_3) (2r^2 \Delta_1^2 + 4\Delta_3 - 8\Delta_{1,0}^\mu) \\ & + 4(c_\mu + 2r^2 \Delta_1) (4s_\mu^2 \Delta_{1,0}^\mu - \Delta_{1,1}^\mu), \end{aligned}$$

$$I_1^{(1)} = 2r[-4\Delta_3^2 + \Delta_{1,1}^\mu + (16\Delta_3 - 4s_\mu^2) \Delta_{1,0}^\mu],$$

$$\begin{aligned} J_1^{(1)} = & 4r\Delta_1 [(\Delta_4 + 8r^2 \Delta_1 \Delta_3) (\Delta_3 - 4\Delta_{1,0}^\mu) \\ & + (c_\mu + 2r^2 \Delta_1) (4s_\mu^2 \Delta_{1,0}^\mu - \Delta_{1,1}^\mu)], \end{aligned}$$

$$\begin{aligned} I_1^{(2)} = & \Delta_3 \Delta_4 - c \Delta_3^2 + \left(\frac{1}{4} c - c_\mu \right) \Delta_{1,1}^\mu \\ & + [(4c_\mu - c) s_\mu^2 - 2\Delta_4 + 4\Delta_3 (c - 2c_\mu)] \Delta_{1,0}^\mu, \end{aligned}$$

$$J_1^{(2)} = (\Delta_4 + 8r^2 \Delta_1 \Delta_3) \left[-2\Delta_3^2 + \frac{1}{2} \Delta_{1,1}^\mu + 2(4\Delta_3 - s_\mu^2) \Delta_{1,0}^\mu \right].$$

For quark bilinear operators, we parametrize V_Γ , V_{Γ^\otimes} , and $V_{\Gamma'}$ as follows:

$$\begin{aligned} V_\Gamma = & A^{(1)} + h_1(\Gamma) A^{(2)} + h_2(\Gamma) A^{(3)} + c_{SW} h_3(\Gamma) A^{(4)} \\ & + c_{SW}^2 [h_4(\Gamma) A^{(5)} + h_1(\Gamma) A^{(6)}], \end{aligned}$$

TABLE VII. Factors for γ matrix contractions. Values in parentheses are for the 't Hooft–Veltman definition of γ_5 ; others are for anticommuting γ_5 .

Γ	$h_1(\Gamma)$	$h_2(\Gamma)$	$h_3(\Gamma)$	$h_4(\Gamma)$	$j(\Gamma)$	$3h_2/8+j$	$1+h_1/4$	h_2-16	$h_1-h_4/3$
$\gamma_\mu\gamma_5$	2	4	-6	0	-2(-6)	-1/2(-9/2)	3/2	-12	2
γ_μ	-2	4	6	0	-2	-1/2	1/2	-12	-2
γ_5	-4	16	0	-12	-4(4)	2(10)	0	0	0
1	4	16	-24	-12	-4	2	2	0	8
$\sigma_{\mu\nu}$	0	0	4	4	0	0	1	-16	-4/3

$$\begin{aligned}
 V_{\Gamma^\otimes} = & \left(1 + \frac{1}{4}h_1(\Gamma)\right)B^{(1)} + [h_2(\Gamma) - 16]B^{(2)} \\
 & + c_{SW} \left[h_3(\Gamma)B^{(3)} + \left(1 + \frac{1}{4}h_1(\Gamma)\right)B^{(4)} \right] \\
 & + c_{SW}^2 \left(h_1(\Gamma) - \frac{1}{3}h_4(\Gamma) \right) B^{(5)},
 \end{aligned}$$

$$\begin{aligned}
 V_{\Gamma'} = & C^{(1)} + \frac{1}{4}h_1(\Gamma)C^{(2)} + \frac{1}{12}[h_2(\Gamma) - 16]C^{(3)} \\
 & + \frac{1}{12}h_4(\Gamma)C^{(4)} + c_{SW} \left[\frac{1}{4}h_1(\Gamma)C^{(5)} \right. \\
 & \left. + \frac{1}{12}h_3(\Gamma)C^{(6)} \right] \\
 & + c_{SW}^2 \left[\frac{h_1(\Gamma)}{4}C^{(7)} + \frac{h_4(\Gamma)}{12}C^{(8)} \right],
 \end{aligned}$$

where $h_i(\Gamma)$ ($i=1, \dots, 4$) are given in Table VII. The explicit form of $A^{(n)}$ is given by

$$\begin{aligned}
 A^{(n)} = & 16\pi^2 \int \left[\frac{1}{F_0^2} a^{(n)} \frac{1}{G_0} - \frac{1}{(k^2)^2} \theta(\pi^2 - k^2) \delta_{n,3} \right] \\
 & + \log \pi^2 \delta_{n,3},
 \end{aligned}$$

where

$$a^{(1)} = 16(\Delta_3 + r^2\Delta_1^2)^2 + \frac{16}{3}\{\Delta_3^2 - \Delta_{1,1}^\mu + 4(s_\mu^2 - \Delta_3)\Delta_{1,0}^\mu\},$$

$$a^{(2)} = 4r^2\Delta_1^2[\Delta_3 - 4\Delta_{1,0}^\mu],$$

$$a^{(3)} = \frac{1}{3}[-4\Delta_3^2 + \Delta_{1,1}^\mu + (16\Delta_3 - 4s_\mu^2)\Delta_{1,0}^\mu] = \frac{1}{6r}I_1^{(1)},$$

$$a^{(4)} = -2r\Delta_1 a^{(3)},$$

$$a^{(5)} = -r^2\Delta_1^2 a^{(3)},$$

$$a^{(6)} = -3\Delta_3 a^{(3)}.$$

The $B^{(n)}$ terms have the form

$$B^{(n)} = 16\pi^2 \int \frac{1}{F_0} \left\{ \frac{b_0^{(n)}}{F_0} + b_1^{(n)} \right\} \frac{1}{G_0},$$

with

$$b_0^{(1)} = 32\Delta_3[-r\Delta_3\Delta_1 + 4r\Delta_1\Delta_{1,0}^\mu],$$

$$b_1^{(1)} = 2r\Delta_1(4\Delta_3 - 16\Delta_{1,0}^\mu),$$

$$b_0^{(2)} = 2r\Delta_1 a^{(3)}, \quad b_1^{(2)} = 0,$$

$$b_0^{(3)} = 2(\Delta_3 - r^2\Delta_1^2)a^{(3)}, \quad b_1^{(3)} = 0,$$

$$b_0^{(4)} = 0, \quad b_1^{(4)} = 6a^{(3)},$$

$$b_0^{(5)} = -6r\Delta_1\Delta_3 a^{(3)}, \quad b_1^{(5)} = 0,$$

and the terms $C^{(n)}$ are written as

$$C^{(n)} = -16\pi^2 r^2 \int \frac{1}{F_0} \left\{ \frac{c_0^{(n)}}{F_0} + c_1^{(n)} \right\} \frac{1}{G_0},$$

where

$$c_0^{(1)} = -16r^2\Delta_1^2\Delta_3^2, \quad c_1^{(1)} = 0,$$

$$c_0^{(2)} = 16r^2\Delta_1^2[r^2\Delta_3\Delta_1^2 - 4r^2\Delta_1^2\Delta_{1,0}^\mu], \quad c_1^{(2)} = 0,$$

$$c_0^{(3)} = 4r^2\Delta_1^2[-4\Delta_3^2 + \Delta_{1,1}^\mu - 4s_\mu^2\Delta_{1,0}^\mu], \quad c_1^{(3)} = 0,$$

$$c_0^{(4)} = -64r^2\Delta_1^2\Delta_3\Delta_{1,0}^\mu, \quad c_1^{(4)} = 0,$$

$$c_0^{(5)} = 0, \quad c_1^{(5)} = 6r\Delta_1 a^{(3)}$$

$$c_0^{(6)} = 24r\Delta_1\Delta_3 a^{(3)}, \quad c_1^{(6)} = 0,$$

 TABLE VIII. One-loop corrections for coupling constants d_g, d_f and plaquette c_p .

Gauge action		d_g	c_p
c_1	c_{23}		
0	0	-0.4682	1/3
-1/12	0	-0.2361	0.2442
-0.331	0	0.1000	0.1402
-0.27	-0.04		0.1472
-0.252	-0.17	0.1196	0.1286

$$c_0^{(7)} = -12r^2 \Delta_1^2 \Delta_3 a^{(3)}, \quad c_1^{(7)} = 0,$$

$$c_0^{(8)} = -12\Delta_3^2 a^{(3)}, \quad c_1^{(8)} = 0.$$

APPENDIX B

In this appendix we collect results for the one-loop relation between the $\overline{\text{MS}}$ and the bare coupling constant. This relation has the general form

$$\frac{1}{g_{\overline{\text{MS}}}^2(\mu)} = \frac{1}{g^2} + \left(d_g + \frac{22}{16\pi^2} \log(\mu a) \right) + N_f \left(d_f - \frac{4}{48\pi^2} \log(\mu a) \right),$$

where d_g only depends on the gauge action [23–28] (see

Table VIII), and d_f only depends on the fermion action: $d_f = 0.0066949$ for a massless Wilson quark action [25] and $d_f = 0.0314917$ for a massless clover quark action with $c_{SW} = 1$ [29]. Using the average value of plaquette at one loop,

$$P = 1 - c_p g^2,$$

we may rewrite the relation as [30]

$$\frac{1}{g_{\overline{\text{MS}}}^2(\mu)} = \frac{P}{g^2} + \left(d_g + c_p + \frac{22}{16\pi^2} \log(\mu a) \right) + N_f \left(d_f - \frac{4}{48\pi^2} \log(\mu a) \right).$$

Numerical values of c_p are also collected in Table VIII.

-
- [1] A. Gonzales-Arroyo, F. J. Yndurain, and G. Martinelli, Phys. Lett. **117B**, 437 (1982).
- [2] G. Martinelli and Y. Zhang, Phys. Lett. **123B**, 433 (1983).
- [3] R. Groot, J. Hoek, and J. Smit, Nucl. Phys. **B237**, 111 (1984).
- [4] G. Martinelli, Phys. Lett. **141B**, 395 (1984).
- [5] C. Bernard, A. Soni, and T. Draper, Phys. Rev. D **36**, 3224 (1987).
- [6] G. Curci, E. Franco, L. Maiani, and G. Martinelli, Phys. Lett. **B 202**, 363 (1988).
- [7] H. Hamber and C. M. Wu, Phys. Lett. **133B**, 351 (1983).
- [8] E. Gabrielli, G. Martinelli, C. Pittori, G. Heatlie, and C. T. Sachrajda, Nucl. Phys. **B362**, 475 (1991).
- [9] R. Frezzotti, E. Gabrielli, C. Pittori, and G. C. Rossi, Nucl. Phys. **B373**, 781 (1992).
- [10] A. Borrelli, C. Pittori, R. Frezzotti, and E. Gabrielli, Nucl. Phys. **B409**, 382 (1993).
- [11] S. Capitani, M. Göckeler, R. Horsley, H. Perlt, P. Rakow, G. Schierholz, and A. Schiller, Nucl. Phys. B (Proc. Suppl.) **63**, 874 (1998); hep-lat/9711007.
- [12] B. P. G. Mertens, A. S. Kronfeld, and A. X. El-Khadra, Phys. Rev. D **58**, 034505 (1998).
- [13] M. Lüscher and P. Weisz, Nucl. Phys. **B479**, 429 (1996).
- [14] S. Sint and P. Weisz, Nucl. Phys. **B502**, 251 (1997).
- [15] B. Sheikholeslami and R. Wohlert, Nucl. Phys. **B259**, 572 (1985).
- [16] G. Heatlie, C. T. Sachrajda, G. Martinelli, C. Pittori, and G. C. Rossi, Nucl. Phys. **B352**, 266 (1991).
- [17] CP-PACS Collaboration, S. Aoki, G. Boyd, R. Burkhalter, S. Hashimoto, N. Ishizuka, Y. Iwasaki, K. Kanaya, T. Kaneko, Y. Kuramashi, M. Okawa, A. Ukawa, and T. Yoshi, Nucl. Phys. B (Proc. Suppl.) **60A**, 335 (1998); *ibid.* **63**, 221 (1998).
- [18] Y. Iwasaki, preprint, Report No. UTHEP-118, 1983.
- [19] P. Weisz, Nucl. Phys. **B212**, 1 (1983); P. Weisz, and R. Wohlert, *ibid.* **B236**, 397 (1984); **B247**, 544(E) (1984).
- [20] M. Lüscher and P. Weisz, Commun. Math. Phys. **97**, 59 (1985).
- [21] K. G. Wilson, in *Recent Development of Gauge Theories*, edited by G. 't Hooft *et al.* (Plenum, New York, 1980).
- [22] S. Sint, ‘‘Current normalization in perturbation theory — Wilson’s Lattice QCD with Sheikholeslami-Wohlert improvement,’’ report, 1996 (unpublished).
- [23] A. Hasenfratz and P. Hasenfratz, Phys. Lett. **93B**, 165 (1980); Nucl. Phys. **B193**, 210 (1981).
- [24] R. Dashen and D. Gross, Phys. Rev. D **23**, 2340 (1981).
- [25] H. Kawai, R. Nakayama, and K. Seo, Nucl. Phys. **B189**, 40 (1981).
- [26] P. H. Weisz, Phys. Lett. **100B**, 331 (1981).
- [27] A. Ukawa and S.-K. Yang, Phys. Lett. **137B**, 201 (1984).
- [28] Y. Iwasaki and S. Sakai, Nucl. Phys. **B248**, 441 (1984); Y. Iwasaki and T. Yoshie, Phys. Lett. **143B**, 449 (1984).
- [29] S. Sint and R. Sommer, Nucl. Phys. **B465**, 71 (1996).
- [30] A. X. El-Khadra, G. M. Hockney, A. S. Kronfeld, and P. B. Mackenzie, Phys. Rev. Lett. **69**, 729 (1992).