

Chapter 2

Literature review

2.1 Soil compaction

2.1.1 Definition and nature of soil compaction

Soil compaction is conceptually well-defined as a reduction of the volume occupied by the given mass. Gill and Vandenberg³¹⁾ explained that soil compaction is a static state property of soil. For a specific soil, the material properties generally do not change when the state of compactness is changed; only the static state changes. However, since soil material and state of compactness indicate a probable change in behavioral properties, the soil is affected by compaction.

2.1.2 Causes of soil compaction

Field soil compaction occurs both naturally by weathering and mechanically by operation of agricultural machines. Rainfall is a simple example of the natural causes of compaction of soil. However, it has been reported that the most serious effect of soil compaction is induced by farm machinery. The increase in volume and weight of farm machines in modern mechanized agriculture has been recognized for undesired soil compaction in the field. Particularly, wheel traffic has been recognized as a major source of force causing soil compaction^{13),19),69),72),85)}. Chi *et al.*¹⁹⁾ stated that soil compaction is a complex process which is governed by the weight of equipment, soil-tire contact pressure, soil condition and number of wheel passes. Söhne⁸⁵⁾ concluded from the results of tests on soil compaction under tractor tire, that the degree of soil compaction depends upon the axle load and contact pressure between the soil and tire.

2.1.3 Effects of soil compaction

Deterioration of soil structure due to compaction often leads to a low seedling emergence rate, shallow root establishment, and high water and nutrient stress on plant growth which may transfer into a reduction in yield⁹⁾. Previous researchers have widely studied the reductions of crop yield caused by soil compaction for many kinds of crops such as corn^{28),29),67),69),70),77)}, wheat^{26),95)} and potato^{78),88),89)}.

The impact of soil compaction has been recognized not only in an agricultural aspect but also in an environmental issue. Soane and Van-Ouwerkerk⁸³⁾ investigated the possible serious, widespread and long-term implications of soil compaction for quality of environment. They concluded that soil compaction is shown to result in changes of soil properties which control the emission of greenhouse gases (particularly carbon dioxide, methane and nitrous oxide), the runoff of water and pollutants into surface waters, and the movement of nitrate and pesticides into ground waters. Horn *et al.*³⁶⁾ noted that applied external stress caused physical and chemical processes, such as mass flow and diffusion of water, ions and gases, being at least retarded or even completely altered.

2.1.4 Researches needed on soil compaction

Even though many researches on soil compaction have been widely carried out, further researches are still needed to help explain the complicated behavior of soil compaction. Schafer *et al.*⁷⁵⁾ suggested that future soil compaction researches should include the following objectives:

1. To develop methods of predicting the force systems, from machinery or other sources which influence compaction.
2. To develop methods for predicting the propagation of compaction forces (stress propagation) in the soil as the function of soil texture, soil structure, matrix

potential, time, frequency, and intensity of loading.

3. To develop methods for predicting the soil response to compaction forces (compaction behavior).
4. To develop standard or simple material tests that identify the parameters pertinent to compaction.
5. To develop specifications for the limits of compactness that are required for optimizing the traction and mobility of machine in the field.
6. To develop specifications for the limits of compactness that may be required by the various aspects of cropping system (plant, fluid and gaseous movements, and biological and chemical activities).
7. To develop management systems that include the management of compaction for all aspects of crop production.

2.2 Current situation of researches on soil compaction

In the past, researches on soil compaction could mainly be categorized as follows:

2.2.1 Behavior of traffic-induced soil compaction

Many researches have been conducted to investigate and clarify the behavior of soil compaction induced by machinery traffic. They have confirmed that machinery traffic is a major cause of field soil compaction. The factors involved and levels of their influences have been investigated particularly for major factors: number of passage and axle load. Jorajuria *et al.*⁴⁵⁾ showed that for the same number of traffic passes, the heavier tractor increased greater bulk density compared with the lighter one. However, the lighter tractor with a larger number of passes produced as much or even greater compaction than the

heavier one with fewer passes. Similar results were also observed by Alakukku and Jurkeiwicz⁷⁾, Mikosz⁸²⁾ and Wiermann *et al.*⁹⁴⁾

The occurrence of soil compaction has been reported in both arable and subsoil layers. In arable layer, kneading of the soil aggregate structure that was produced by running devices of a machine caused change of soil structure and totally destroyed soil aggregates and large free pore spaces⁸²⁾. Works of Chamen and Longstaff⁸⁸⁾ represented that average cone resistance over the depth range 0 to 5 cm was higher on trafficked than control plots. The effect of soil compaction persisted even after plowing⁹⁾. In subsoil, Håkkansson *et al.*⁴³⁾ reported that in 17 fields in a region with intensive machinery traffic, the penetration resistance at 40 cm depth was on average 40% higher in the fields than in the control areas.

The behavior of soil compaction was also influenced by type of field operation⁷³⁾, wheel traffic system, tillage system, cropping system and tillage treatment. Douglas and Koppi²¹⁾ presented that the volume of macropores in the soil of a zero traffic system was greater by a factor of two than that in soil after conventional or reduced ground pressure traffic. Bordovsky *et al.*¹⁴⁾ stated that bulk density under a reduced tillage system was higher than the one with the conventional tillage system. However, saturated hydraulic conductivity of the surface soil was increased by reduced tillage practices compared with conventional tillage. This may have been attributable to higher amounts of microaggregates and larger macropores under a reduced tillage system. These coincided with the results proposed by Hussain *et al.*³⁸⁾ in which the higher bulk density in surface layer appeared in a no-tillage system than in a chisel and a moldboard plow system but better soil water storage was found in a no-tillage system. In addition, in different treatment between moldboard plowing to 25 cm and tine chiseling to 10-15 cm, in the

uppermost layer (0-15 cm), the soil properties were more or less identical in the different tillage treatments. However, at a greater depth than 15 cm, the unplowed soil had higher bulk density, greater penetration resistance and greater aggregate tensile strength than the moldboard plowed soil. Nevertheless, the air permeability was higher in the unplowed soil at the same air-filled porosity, suggesting a greater degree of pore continuity⁸⁾.

2.2.2 Methods to estimate soil compaction

Many techniques and instruments have been developed for estimating field soil compaction. To determine the effects of compaction on structure-dependent soil properties, O'Sullivan and Simota⁶³⁾ proposed empirical equations, called pedotransfer function. O'Sullivan *et al.*⁶⁴⁾ also developed a simplified model that allows users to explore some of the main aspects of soil compaction which was intended for non-expert users such as students. Carlos Manoel Pedro Vaz *et al.*¹⁵⁾ introduced the new procedure of gamma-ray attenuation technique for particle size analysis and reported that its advantages included automation of analysis, decreasing time and minimum influence by operator expertise.

For stress-strain relations, Dawidowski²⁰⁾ proposed the equations describing stress-strain relations and the models used to predict mechanical stress distribution profiles and estimate the effect of applied tire pressures on soil compaction. Raper *et al.*⁷¹⁾ used finite element modelling technique to predict and avoid excessive soil compaction. The non-linear stress-strain relationship used showed that soil compaction was a function of both normal and shearing stress. In simulating soil deformation, Oida *et al.*⁶⁵⁾ used the technique of distinct element method (DEM) while Kirby *et al.*⁵⁰⁾ introduced a critical-state finite element model to simulate compaction under single and dual tires and tracks.

Improvement of the soil penetrometer and estimation of penetration resistance have also been widely carried out. Matteo *et al.*⁵⁵⁾ proposed a method to discriminate

penetrometer resistance due to different soil treatments by means of principal component analysis. Kuldip Kumar *et al.*⁵³⁾ conducted tests to estimate penetration resistance from soil physical properties, including soil water content as a dynamic variable, and several soil state variables, namely texture, bulk density, and over-burden pressure, and soil depth and sand content. Foster *et al.*²⁷⁾ developed beneficial Finite Element (FE) to simulate cone penetration in a virtual soil using the commercial FE software MSC/DYTRAN. Shibuya *et al.*⁸⁰⁾ proposed an instrument developed for easy and accurate measurement of penetration resistance to evaluate soil compaction generated by vehicle traffic in meadows. The instrument was adjustable to enable vertical penetration on slopes, but was limited to an inclination of less than 25° and average time required for one measurement was about 2-3 min.

Alexandrou and Earl⁶⁾ developed the method to predict the stress at compaction point by using data collected from stress-sinkage tests which are simply obtained from simple plate sinkage tests. Earl²²⁾ also conducted plate sinkage tests to assess the behavior of field soil during compression. Adam and Erbach¹⁾ established the relationship of tire sinkage depth to depth of soil compaction. Compaction depth (compaction defined by bulk density of 50kg/m³), Y, was found to be related to sinkage depth, X, by the empirical equation, $Y = bX^m$, where b and m are regression constants.

Bailey *et al.*¹⁰⁾ and Bakker *et al.*¹¹⁾ developed the application of a stress state transducer to measure stress state in the soil profile and soil-tire interface stresses in order to represent the soil compaction process and interpret stress paths under agricultural vehicle. Kirby⁴⁸⁾ adopted the finite element method to examine the stresses predicted around transducers in uniformly applied vertical stress fields. He stated that many factors influenced the stresses estimated by soil stress transducer. Kirby⁴⁹⁾ also confirmed that

stresses can be over- or under-estimated depending on conditions, with disturbed zones of soil, degree of elastic as opposed to elastoplastic behavior, depth in the soil, tire size and hardpan affecting the results.

2.2.3 Other parameters affecting soil compaction

Arvidsson⁷⁾ described the influence of soil texture and organic matter content on soil physical properties and crop yield, both in the field and after uniaxial compression. They found that bulk density decreased while air content increased with increasing organic matter content. Besides, they noted that the compression index in the field was virtually unaffected by soil texture and organic matter content in the field. The effect of organic matter on the strength properties of compacted agricultural soil was also reported by Ekwue and Stone²⁴⁾. Sánchez-Girón *et al.*⁸⁴⁾ tried to simulate the soil compaction of five types of soil in a Spanish dry-farming region by adopting the method of confined uniaxial compression. The results showed that the higher the clay content, or the presence of a loam texture, the higher the soil capacity to bear higher normal stresses at higher water contents without reaching a severe state of compactness.

2.2.4 Influences of soil compaction on growing plant

Alakukku and Elonen⁵⁾, who studied the long-term effects of compaction on yield and nitrogen uptake in clay and organic soil, presented that as a mean of the first 8 years, compaction of the clay soil with four passes reduced the yields by 4 % and nitrogen uptake of annual crop by .9%. Ngunjiri and Siemens⁶²⁾ also reported that maize yield with compaction on the entire plot area averaged 9.8 t/ha, which was significantly lower than yields from no compaction, compaction between rows and compaction on the rows, which average 12.5, 12.6 and 12.6 t/ha, respectively.

The impact of soil compaction also appeared on seed emergence and root growth. Nasr and Selles⁶¹⁾ found that the number of seedling emerged and speed of emergence were affected by bulk density and aggregate size of seedling, and by the interaction of both variables. In general, increasing bulk density and aggregate size delayed emergence and reduced total emergence. Montemayor⁶⁰⁾ also confirmed this impact. Moreover, it was found that soil strength enhanced the negative effect of temperature on the shoot growth of maize. According to Weaich *et al.*⁹²⁾, when seedbed strength increased, high temperature stress had reduced the expansion pressure of the first internode of root. Gemtos and Lellis³⁰⁾ additionally reported that plant types should also be taken into consideration for the effect of soil compaction. They showed that emergence and initial growth of sugar beet is more sensitive to compaction than that of cotton.

Soil compaction also has positive effects on plant growing as described by Wade *et al.*⁹⁰⁾ In the rainfed lowlands, a hardpan may be beneficial if leaching loss is reduced. In tests in Thailand, daily water use was halved by subsoil compaction and percolation was reduced by a factor of eight relative to dry tillage. Pradeep *et al.*⁶⁸⁾ confirmed that grain yield increased by 88% after subsoil compaction was created.

2.2.5 Degree of compactness suitable for growing plant

Gemtos and Lellis²⁹⁾ reported that the pressure of 150-250 kPa benefited cotton plants, giving maximum daily growth, final height and maximum production of aerial dry matter. For sugarbeet, a pressure of 50-200 kPa gave best results for growth. Ekeberg and Riley²³⁾ found that the suitable compactness depended on the growing plant. The yields level of cereals and potatoes growing on loam soil in Southeast Norway showed consistent increases of 2-8% with declining tillage intensity, whereas yields of fodder beet were highest after plow tillage. They described that this was due to lower soil temperature under

reduced tillage. According to Pabin *et al.*⁶⁶⁾, the suitable bulk density was also affected by water contents. The results of tests for determining critical bulk density as an indicator of very poor root growth, showed that critical bulk density and strength decrease as soil water content decreases.

Medvedev and Cybulko⁵⁸⁾ proposed six criteria to determine the maximum permissible ground pressure of agricultural vehicle to permit satisfactory crop production on loamy Chernozem soil. It included (1) changes in soil water and physical property; (2) crumbling characteristics; (3) depth of compaction; (4) rut depth; (5) soil strength potential; (6) self-loosening characteristics.

2.2.6 Reduction of soil compaction in a field

Håkansson *et al.*⁴²⁾ stated that the protection of soils from mechanical overloading by establishing limits of stresses caused by heavy vehicles is needed so as to: (1) improve efficiency and resource economy of the crop production system in the short term; (2) ensure soil productivity in the long term; (3) reduce the negative impact of crop production on the environment. Many efforts have been made to reduce the field soil compaction. Tessier *et al.*⁸⁷⁾ modified a one way disker by increasing its diameter in order to reduce soil compaction for eastern Canada conditions. The test results showed that while a plow pan reappeared within 2 years after subsoiling under conventional tillage, the modified one-way disker (MOD) maintained a relative uniform bulk density profile without resulting in the formation of a plow pan. Furthermore, the MOD not only prevented recompaction of the subsoil profile, but also seemed to favor an alleviation of previous subsoil compaction. Ess *et al.*²⁵⁾ reported that in a rye cover plot multiple machine passes produced significantly lower dry bulk densities and higher non-capillary porosities compared to the bare soil plot for soil surface layer (25-75 mm). Soil compaction appeared to be reduced by the

reinforcing created by a network of undisturbed roots within the soil. Adawi and Reeder²⁾ also reported that subsoiling generally improved yields. Subsoiling the compacted plots removed the compaction effect and improved the control substantially.

2.2.7 Effects of soil compaction on the quality of the environment

Soane and Van-Ouwerkerk⁸³⁾ indicated the possible serious, widespread and long-term implication of soil compaction for quality of the environment. Soil compaction results in changes of soil properties which control the emission of greenhouse gases, the runoff of water and pollutants into surface water, and the movement of nitrate and pesticides into ground water. Soil compaction will also affect the amounts of fertilizer and energy used in crop production, which may have additional adverse environmental consequences. Horn *et al.*³⁷⁾ also confirmed that reduced water permeability by soil compaction might result in soil erosion, with serious negative effects on the environment. Compacted soil may also contribute to global atmospheric warming due to increased emission of CO₂, CH₄ and N₂O from such soil. In addition, Lipiec and Stepniewski⁵⁴⁾ stated that the negative effects of soil compaction on components of the environment are due to nutrient leaching, surface runoff and gaseous losses to the atmosphere.

2.2.8 Chemical and biological effects of soil compaction

Matychenkov *et al.*⁵⁶⁾ described that mechanical compaction of Chernozem soils in the Azov region of Russia caused substantial changes in the chemical and electrochemical properties of soil. Soil compaction caused a decrease in the amount of soluble silicon compounds. Polysilicic acids increased and monosilicic acids decreased. These changes were reflected in the agrophysical and agronomical properties of the soil and the decrease in the amount of silica available to plants. Lipiec *et al.*⁵⁴⁾ stated that soil compaction and tillage systems affected the uptake and losses of nutrients. Whalley *et al.*⁹³⁾ considered the

microbial activity and biological interactions from the effects of compaction and found that it depends on its management history. Also, they called for further research on the effect of soil compaction on biological processes in order to develop systems of agriculture which are sustainable and ecological.

2.3 Stress on soil

2.3.1 The stress state on soil

In order to specify the state of stress at a point in soil, nine quantities that are referred to as a tensor by mathematical definition are required³¹⁾. These nine components of a stress tensor at their point are shown in Fig. 2.1. However, certain simplifications are possible with the help of symmetry and equilibrium of some components which can be

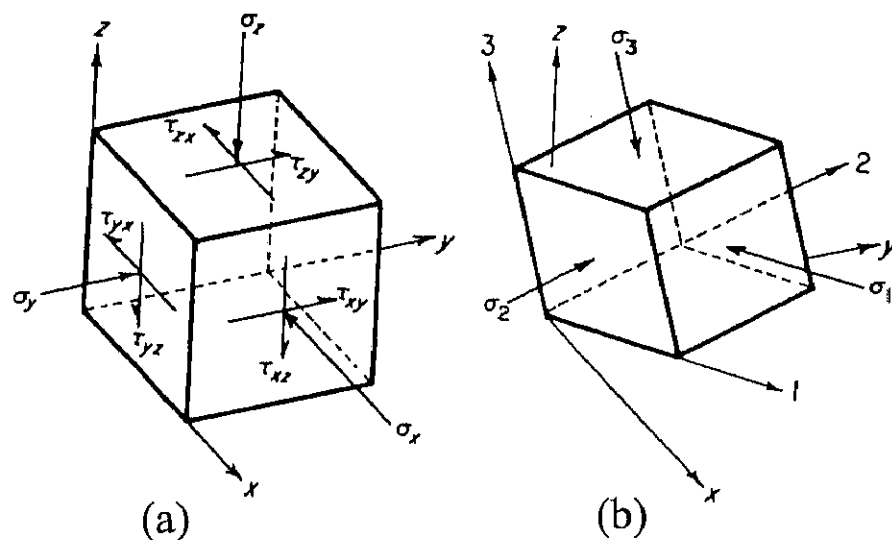

Fig. 2.1 Stress components on a soil element

(a) stress relative to arbitrary axes x, y, z

(b) principal stress cube

expressed with $\tau_{xy} = \tau_{yx}$, $\tau_{xz} = \tau_{zx}$, and $\tau_{yz} = \tau_{zy}$. By utilizing this method, three of the unknowns can be eliminated so that only six independent values must be specified to describe the state of stress at one point in soil.

A property of the stress tensor is that the coordinate axes can always be rotated so that all shear stress will be zero and only normal stresses will act on the three mutually perpendicular planes. The three normal stresses are well-known as principal stresses, and their directions are the principal axes of the stress state. The mean normal stress σ_m can be derived from,

$$\sigma_m = (\sigma_1 + \sigma_2 + \sigma_3)/3 \quad (2.1)$$

where σ_1 , σ_2 and σ_3 are principal stresses.

2.3.1.1 Effective stress

Soil is a discontinuous material. It is composed of three phases: soil particle, water and air in pore space. The fraction of water and air in pore space depends on the degree of saturation. Hence, when load is applied to soil, these three parts share the task of supporting the load. In saturated soil, since there are only soil particle and water, the total stress component σ normal to any plane in the soil is divided into two parts; the pore water pressure, u_w , and the effective stress component, σ' , which must be considered to be effectively carried by the structure of the soil particle. The effective stress is simply calculated as

$$\sigma' = \sigma - u_w \quad (2.2)$$

This equation was first proposed by Terzaghi.

For partially saturated soil, the effective stress can be represented by

$$\sigma' = \sigma - u_a + \chi(u_a - u_w) \quad (2.3)$$

Where u_a is pore air pressure and χ is wetted area per unit gross area of partially saturated

soil³⁴⁾.

Schofield and Wroth⁷⁶⁾ explained that, in nature, when external stress is applied to saturated soil, pore water will carry the entire stress increment at the point of loading. Eventually, at the completion of drainage, the soil skeleton carries the entire load increment.

2.3.1.2 State space

Roscoe *et al.*⁷⁴⁾ developed the Hvorslev's equation for the shear strength to define a surface in a space of three variables p , q and v . The ideas have changed over the years and experimental proof of all propositions has made all the arguments rather long.

The basic theories were first developed from the data obtained from saturated soil. However, for partly saturated soil usefulness was confirmed by Hettiarachi and O'Callaghan³⁴⁾.

The state space is used to determine the state of stress. All possible states of existence of the soil element can be represented by points in p - q - v space. When a soil element undergoes shear deformation ultimately reaching a critical state, it will flow without further change in p , q or v . The locus of such points in p - q - v space is unique for a given soil element and it is called the critical state line. A plot of a critical state line is shown in Fig. 2.2. This is an extremely elegant idea that indicates the ultimate state reached by the loaded soil element and the directions in p - q - v space which the changes in stresses and specific volume must lead to as the soil is being deformed.

Not all combinations of p , q and v are possible in practice and certain boundaries limiting the values of p , q and v have to be identified. Such boundaries will be referred to as state boundaries and the loci of possible values of p , q and v traced out by soil element deformation will be referred to as state paths. Thus state paths must at all times lie within

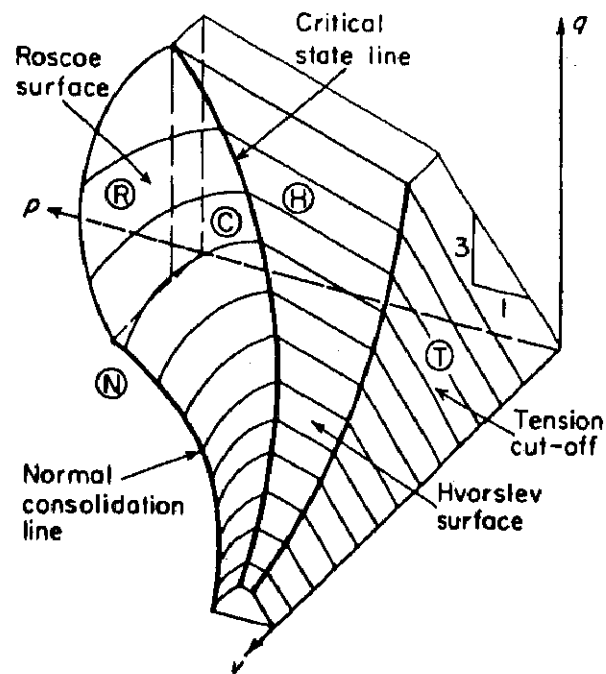

Fig. 2.2 State space.

or traverse the state boundaries but never cross them.

One such state boundary line has already been mentioned as the critical state line. Yet another boundary line is the normal consolidation line, which lies on the $q = 0$ or p - v plane and may be considered as the variation of the largest possible value of v and p during isotropic compression of soil. These two limiting curves are joined by a curved state boundary surface which has been designated as the Roscoe surface. According to experimental work, the space between the critical state line and the origin of co-ordinates of p - q - v space is also limited on its upper end by a state boundary which contains the critical state line and this boundary is a ruled curved surface generated by straight lines which have a fixed gradient H on the $v = 0$ of the p - q plane. This surface is referred to as the Hvorslev surface.

The other surface is T- surface, which is a plane containing the v -axis and inclined

upwards at a slope of 3:1. The sketch shown in Fig. 2.2 illustrates the nature of the state boundaries in p-q-v space and the space enclosed by these boundaries will be referred to as state space.

2.3.2 Stress induced by traffic wheel

2.3.2.1 Estimated stress distribution

The stress distribution on soil under a wheel tire can be predicted by a circular area method.⁵²⁾ In Fig. 2.3, the area of the circle is chosen equal to the area of the soil-tire contact surface and the stress q on the circular area is taken as equal to the mean normal stress in the soil-tire interface. Consider a small horizontal plane below the center of the circular area. Angle α characterizes the depth of plane under consolidation. If $\alpha = 90^\circ$, the plane is at the surface; if $\alpha = 0^\circ$, the plane is infinitely deep. Because of q , there is a normal stress σ_z on the plane. This σ_z is a principle stress and for the depth considered also the

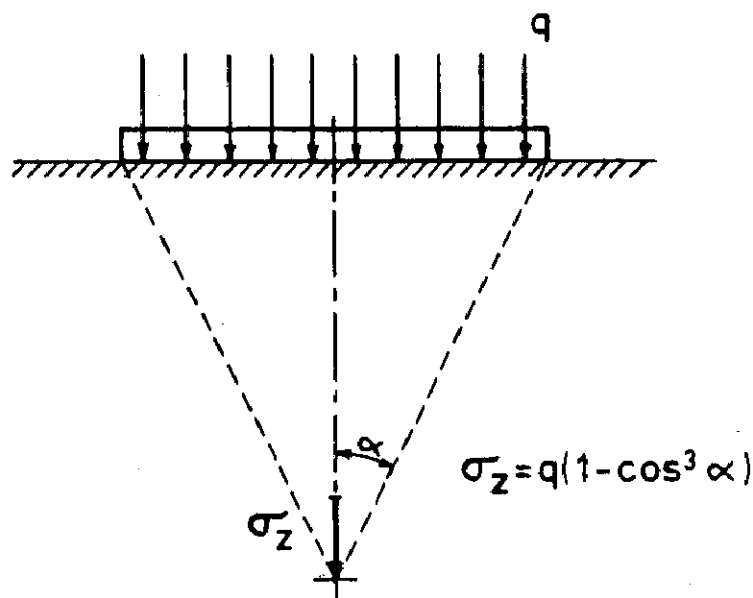

Fig. 2.3 Soil stresses below the center of a uniformly loaded circular area.

greatest stress.

According to Söhne⁸⁵⁾, this stress is firstly given by

$$\sigma_z = q(1 - \cos^3 \alpha) \quad (2.4)$$

If $\alpha = 90^\circ$, $\sigma_z = q$ and if $\alpha = 0^\circ$, $\sigma_z = 0$. This model was, then, modified for differences in soil strength by introducing the concentration factor ν to equation (2.4)

$$\sigma_z = q(1 - \cos^\nu \alpha) \quad (2.5)$$

where $\nu = 3, 4$ or 5 in the case of hard, normal or soft soil, respectively.

2.3.2.2 Stress beneath traffic wheel

Ishihara⁴⁴⁾ described that when the wheel load comes to a position at some distance from the point above the soil element in question, the major component of induced stress is the horizontal shear stress. However, at the instant when the wheel load is located right above the soil element, the horizontal shear stress disappears and in turn the stress difference component dominates. As the wheel load passes by, the soil element again undergoes the horizontal shear stress and eventually becomes free of any stress.

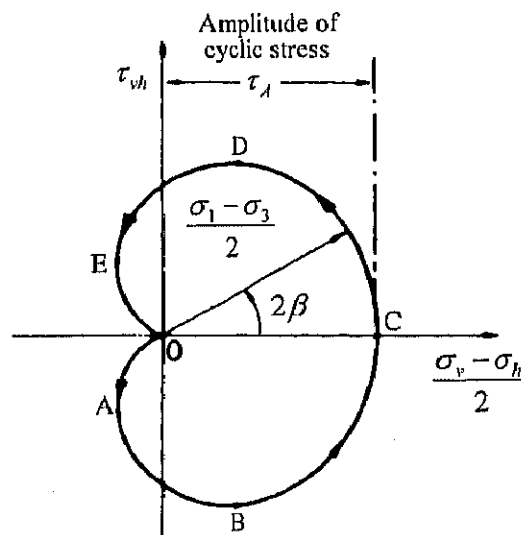

Fig. 2.4 Stress path due to a traveling load.

The stress path during the pass of wheel can be represented in Fig. 2.4. The rotation of principle stress direction takes place first with increasing magnitude and then with decreasing magnitude of deviator stress as the wheel load moves from minus to plus infinity on the ground surface.

Referring to the test result reported by Block *et al.*¹³⁾, peak stress was observed at the axle centerline and tended to decrease according to an increase of distance. Hence, the soil element is loaded with a varying loading magnitude depending on the distance from the wheel. Fig. 2.5 shows stress beneath the wheel obtained by employing a stress state transducer (SST) from tests conducted by Way *et al.*⁹¹⁾ It can be described that the tire approached the transducer from the left (negative distances), and was directly over the transducer at the distance of zero. The vertical pressure was the dominant measured stress.

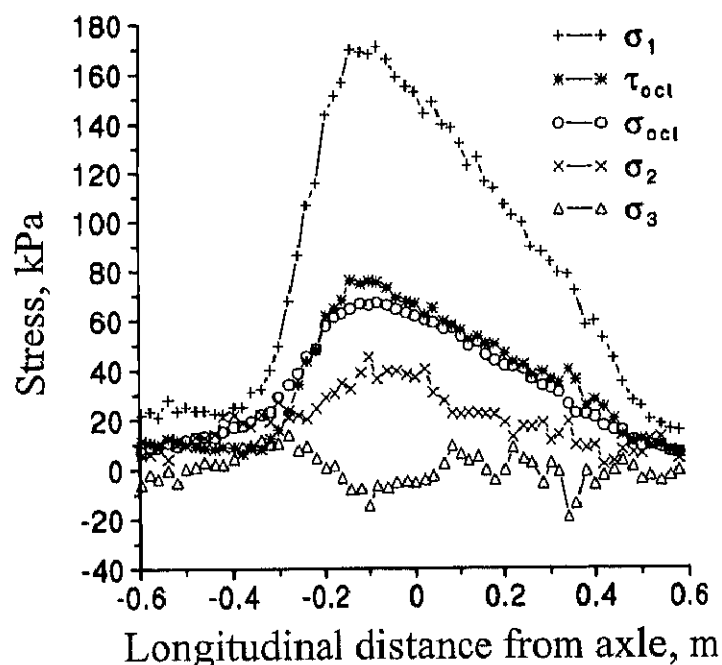

Fig. 2.5 Stresses beneath the centerline of the tire.

After calculation, the representation in terms of corresponding stresses can be provided as shown in the figure. These curves are representative as a general shape and trend of stress beneath the wheel.

Fig. 2.6 presents the stress components when the results from both front and rear wheels were recorded. It shows a typical variation of the stress state in time, with the normal stress, σ_z , reaching a maximum of 130 kPa for the front tire and subsequently 120 kPa for the rear tire, and the shear stresses τ_{xy} , τ_{yz} and τ_{xz} changing in direction during the passage of the wheel³³⁾.

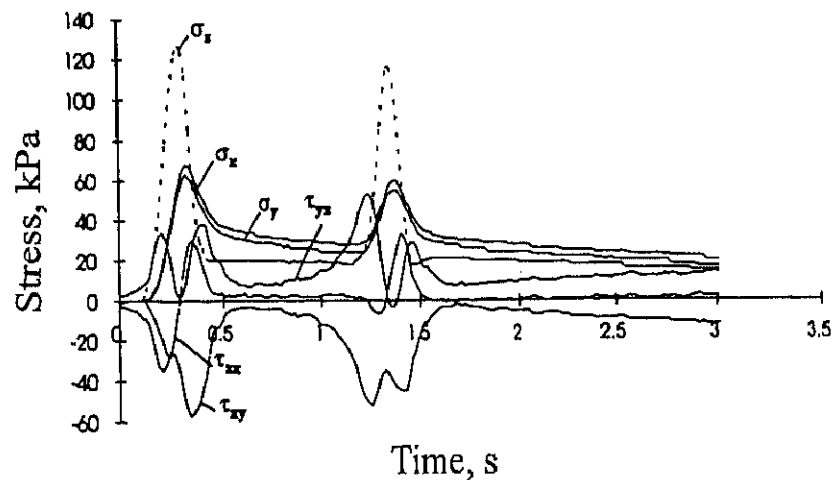

Fig. 2.6 Stress components under front and rear tire.

2.4 The cyclic loading test

The cyclic loading test has been widely performed in the field of civil engineering, particularly against the problems of earthquakes. It is necessary to employ this test to acquire pertinent data for the design of foundations and especially for seismic designs of

critical structures such as large nuclear power storage tanks or high earthfill dams which should be stable even in large earthquake motions. In consideration of earthquake-induced damage to soil structure and foundation in saturated cohesionless soils, two failure modes can be identified. Castro¹⁶⁾, and Castro and Poulos¹⁷⁾ divided the pattern of failure of saturated sands subjected to cyclic shear stresses into liquefaction for contractive samples and cyclic mobility for dilative ones. In the former type of failure, sand deforms continuously in a state of constant stress, termed steady state, as a result of a marked reduction in strength. In the latter case the deformation is the result of progressive stiffness degradation of sand due to a build-up of pore pressure. Significant deformation can develop when the effective stress momentarily becomes zero. These failure characteristics are influenced by initial conditions, such as the initial density and confining pressure³⁹⁾.

Not only for the earthquake, the cyclic loading tests have also been performed extensively for the traffic-induced problem, concerning the investigation of the cumulative deformation characteristics of soil in the subgrade underlying the base course of railways and highways. Ishihara⁴⁴⁾ stated that in many case, the cyclic triaxial test employing a number of load repetitions are conducted for this purpose.

For the liquefaction problem, cyclic loading tests have been widely performed on saturated sand to investigate soil behavior, the liquefaction phenomena and the factors involved. Tatsuoka⁸⁶⁾ carried out the experiment of cyclic undrained stress-strain behavior of dense sands by torsional simple shear test. He established the relationship between consolidated relative density and the number of cyclic loading for several values of cyclic stress ratio amplitude. It was observed that the relative density increased steadily with the increase in the number of loading cycle at constant cyclic stress ratio. The liquefaction strength was reported to be proportional to relative density up to a certain value of relative

density. The effects of initial density¹⁹⁾ and initial static shear stress⁸¹⁾ on liquefaction were also described. The cyclic loading test was also conducted for clay soil. Hyodo *et al.*³⁹⁾ stated that although clay has been considered to be stable in comparison with sand during earthquakes, large ground deformation due to the amplification of seismic motion was recognized as a characteristic of clay behavior.

In the agricultural engineering field, the cyclic loading test is rarely undertaken even though this test seems to be beneficial in solving problems of traffic-induced soil compaction in the field. Normally, laboratory experiments of soil compaction have been conducted in a static condition where the effect of loading speed was controlled by applying load slowly during tests. However, the static test is not suitable to explain the behavior of traffic-induced soil compaction since it provides a different source of external force than would be encountered in field soil during the operation of a tractor.

Among a few tests, Adebisi *et al.*³⁾ conducted cyclic loading tests to investigate the dynamic compaction characteristics of agricultural soil. They reported that the strain produced in the soil by the cyclic excitation was higher at the higher frequency and much higher for the higher cyclic stress ratio at the higher frequency. Moreover, at higher frequency and cyclic stress ratio, a rapid build-up of pore water pressure may result in the rapid yielding of soil. In contrast, a different result on the effect of loading frequency was presented by Koike *et al.*⁵¹⁾. They stated that under the same stress amplitude ratio, the frequency of 0.5 Hz showed greater axial displacement than in the case of 1.0 Hz.

2.5 Rationality of using cyclic torsional shear loading test in simulating traffic-induced loading system

Ishihara⁴⁴⁾ stated that in order to carry out some tests in the laboratory in

simulation of the stress changes during the passage of a wheel load, where a soil element in the ground is subjected to shear stresses involving the rotation of the principal stress axis, the use of a cyclic torsional shear test would be most preferable, because it permits the tests to be run under a controlled combination of torsional shear and axial stresses. First of all, a soil specimen is consolidated under confining stress and then the torsional shear is applied in combination with the axial stress under appropriate drainage conditions for the number of cycles.

In another consideration, this test can simulate directly the torsional shear load that is generated to soil during the turning motion of a wheel where the soil beneath the wheel definitely suffers from this torsional shear action. A similar type of torsional shear load may also appear even in straight running on irregular profile surfaces due to the unavoidable skewing movement of the wheels when corrected manually by the driver to maintain straight driving. Besides, this type of load might be encountered during the work of a machine on hillsides, in particular.