

STUDIES IN LEXICAL NETWORK THEORY

SEIJI IWATA

STUDIES IN LEXICAL
NETWORK THEORY

SEIZI IWATA

寄	贈
岩田	平成
彩志	年
氏	月
	日

98300086

Acknowledgements

"A thesis requires a good amount of help, both spiritual and intellectual." — This phrase, which strikes my fancy, has been borrowed from the acknowledgements of some Ph.D. (Unfortunately, I cannot remember the author's name). I think it is best fitting to start my acknowledgements with this phrase.

I'd like to express my deepest gratitude to Prof. Minoru Nakau, who initially sparked my interest in linguistic semantics and has greatly influenced the direction my research has been taking.

I am also grateful to Shosuke Haraguchi and Yukio Hirose for careful guidance and constant encouragement. Besides reading an earlier version of this dissertation, these three people have taught me a lot of things, both linguistic and extralinguistic, since I was a student of the University of Tsukuba.

In addition to the above-mentioned three, I am really grateful to many of the current and former graduate students of the University of Tsukuba for showing me by example what it is like to pursue one's own ideas without compromising one's beliefs. Among them, Nobuhiro Kaga, Toshifusa Oka, Masaki Sano, to name a few.

I'd also like to thank my colleagues at Gifu University for providing me with a good environment to pursue my studies. Lynne Roecklein has helped me with her sharp intuitions and has been a constant source of encouragement. William Lee generously read earlier versions of all the chapters and gave me detailed comments. John Russell and Barbara Johnston kindly acted as informants.

Earlier versions of some of the chapters were presented at various places. I'd like to thank the audience at these meetings for their comments and criticism.

Seizi Iwata

Gifu-shi, Gifu
November 1995

Table of Contents

Acknowledgements	ii
Introduction	1

PART I

TWO KINDS OF NETWORK

Chapter 1: Multiple Conceptual Structures of a Single Verb: Lexical Abbreviation or Lexical Network?	4
1.0. Introduction	4
1.1. Lexical Abbreviation Analysis	4
1.1.1. Jackendoff (1990)	4
1.1.2. Inadequacies	7
1.2. Analysis	10
1.2.1. Five <u>Hits</u>	10
1.2.2. Relations between <u>Hits</u>	12
1.2.3. Further Senses	16
1.3. Grammatical and Semantic Networks	21
1.3.1. G-Network	21
1.3.2. S-Network	21
1.4. The Necessity of Network	22
1.4.1. <u>Strike</u>	23
1.4.1.1. G-Network	23
1.4.1.2. S-Network	25
1.4.1.3. The Overall Network of <u>Strike</u>	28
1.4.2. Japanese	29
1.4.3. Projection Principle	34
1.5. Conclusion	37
Notes to Chapter 1	37

PART II

G-NETWORK

Chapter 2: Locative Alternation	41
2.0. Introduction	41
2.1. Previous Studies	41
2.1.1. Rappaport and Levin (1988)	42
2.1.2. Pinker (1989)	44

2.2. Analysis	48
2.2.1. L-Meaning and P-Meaning	48
2.2.1.1. <u>Load</u>	48
2.2.1.2. <u>Spray</u>	51
2.2.2. Dative Alternation and Construction Grammar	53
2.2.2.1. Goldberg (1992a)	53
2.2.2.2. Langacker (1986)	54
2.2.3. An Overall Picture	55
2.3. Application	56
2.3.1. <u>Hit</u>	57
2.3.2. <u>Wrap</u>	58
2.4. Means Extension Once Again	60
2.4.1. Why Means Extension?	60
2.4.2. Why Derive One from the Other?	62
2.5. <u>Expect</u>	63
2.6. Conclusion	66
Notes to Chapter 2	66
Chapter 3: The Relevance of Constructions	69
3.0. Introduction	69
3.1. Construction Grammar	69
3.1.1. Goldberg (1992a, 1992b)	69
3.1.2. Fundamental Assumptions	71
3.2. Verbs of Removal	75
3.2.1. Levin and Rappaport (1991)	76
3.2.2. Analysis	78
3.3. Denominal Verbs	83
3.3.1. Locatum Verbs vs. Location Verbs	83
3.3.2. Vagaries of Denominal Verbs	89
3.4. Causative Alternation	91
3.5. Multiple Direct Objects	96
3.5.1. Choice of Object	96
3.5.2. <u>Tie</u>	98
3.6. Concluding Remarks	100
Notes to Chapter 3	101
Chapter 4: Motion and Extent: Two Sides of the Same Coin	103
4.0. Introduction	103
4.1. Analysis	104

4.1.1. Basic Characteristics	104
4.1.2. A Succession of Transitions	107
4.1.3. Eventive GO _{EXT}	110
4.2. Other Approaches	115
4.2.1. Langacker (1986, 1987a, 1987b)	115
4.2.2. Lakoff (1987)	119
4.2.3. Lakoff and Turner (1989)	122
4.3. Further Extensions	125
4.3.1. Mental Scanning Once Again	125
4.3.2. Enriching the Path	128
4.3.2.1. <u>Spread</u>	128
4.3.2.2. <u>Widen, Narrow</u>	130
4.4. Conclusion	132
Notes to Chapter 4	132

PART III

S-NETWORK

Chapter 5: Metaphor and Thematic Relations	136
5.0. Introduction	136
5.1. Characteristics of Metaphor and Thematic Relations	136
5.1.1. Metaphor	136
5.1.2. Thematic Relations	138
5.2. Differences between Metaphor and Thematic Relations	140
5.2.1. Are Thematic Relations Metaphors?	140
5.2.2. Abstract Organizing System	141
5.2.3. Traugott (1985)	141
5.2.4. Jackendoff and Aaron (1991)	142
5.2.5. Jackendoff (1992)	145
5.3. Metaphor as a Set of Correspondences	148
5.3.1. Thematic Relations as Distinct from Metaphor	148
5.3.2. From Invariance Hypothesis to Invariance Principle	149
Notes to Chapter 5	150
Chapter 6: Thematic Parallels and Non-Parallels	152
6.1. Thematic Relations Hypothesis	152
6.2. Non-Spatial Semantic Fields	154
6.2.1. Temporal	154
6.2.2. Possessional	161

6.2.3. Identificational	163
6.2.4. Motion and Path	164
6.2.4.1. Varieties of Motion	165
6.2.4.2. Varieties of Space	165
6.3. Case Studies	166
6.3.1. <u>Between</u> and <u>From-To</u>	166
6.3.1.1. Spatial	166
6.3.1.2. Temporal	168
6.3.1.3. Possessional	169
6.3.1.4. Identificational	170
6.3.2. <u>Over</u>	171
6.3.3. EXTENT	173
6.3.4. <u>Spread</u>	174
6.3.5. <u>Around</u>	175
6.4. Conclusion	177
Notes to Chapter 6	177

PART IV

APPLICATION

Introduction to Part IV	181
Chapter 7: <u>Pass</u>	183
7.1. G-Network	183
7.1.1. Jackendoff (1987)	183
7.1.2. Other Senses	184
7.2. S-Network	185
7.2.1. Temporal	185
7.2.2. Possessional	187
7.2.3. Identificational	188
7.2.4. Existential	188
7.2.5. Linear Scales	188
7.2.6. Conduit Metaphor	188
7.3. Further Senses	191
Notes to Chapter 7	193
Chapter 8: <u>Extend</u>	195
8.1. Two Senses of <u>Extend</u>	195
8.1.1. Jackendoff (1983)	195
8.1.2. Problems	196

8.1.3. Alternative Analysis	198
8.2. Extending the Analysis	201
8.2.1. G-Network	201
8.2.1.1. <u>Extend</u> (C)	201
8.2.1.2. <u>Extend</u> (D)	203
8.2.2. S-Network	204
8.2.2.1. <u>Extend</u> (E)	204
8.2.2.2. <u>Extend</u> (F)	205
8.2.2.3. <u>Extend</u> (G)	205
8.2.2.4. <u>Extend</u> (H)	206
8.2.3. The Network of <u>Extend</u>	206
Notes to Chapter 8	207
Chapter 9: The Story of <u>Cover</u>	209
9.1. Spatial Senses	209
9.2. Further Senses	211
9.2.1. <u>Cover</u> (D), <u>Cover</u> (E), <u>Cover</u> (F)	211
9.2.2. <u>Cover</u> (G)	213
9.2.3. <u>Cover</u> (H)	217
9.3. The Network of <u>Cover</u>	218
Notes to Chapter 9	219
Chapter 10: From Intralexical to Interlexical Relations: Lexical Networks of Verbs with Up-Down Orientation	220
10.0. Introduction	220
10.1. <u>Rise</u>	220
10.1.1. G-Network	220
10.1.2. S-Network	224
10.1.2.1. Extensions of (A)	224
10.1.2.2. Extensions of (B)	227
10.1.2.3. Extensions of (C)	228
10.2. <u>Raise</u>	229
10.2.1. G-Network	229
10.2.2. S-Network	231
10.3. <u>Lift</u>	234
10.3.1. G-Network	234
10.3.2. S-Network	236
10.4. <u>Drop</u>	239

10.4.1. G-Network	239
10.4.2. S-Network	240
10.4.2.1. Extensions of (A)	240
10.4.2.2. Extensions of (B)	240
10.4.2.3. Extension of (C)	242
10.5. <u>Fall</u>	243
10.5.1. G-Network	243
10.5.2. S-Network	244
10.6. Entailment, Synonymy, and Opposition	246
Notes to Chapter 10	248
Summary and Conclusion	250
References	253

Introduction

The purpose of this study is (1) to show that a verb is to be analyzed as a network of interrelated senses, which consists of two kinds of sub-network, and (2) to investigate the links constituting the network. It also aims to explore, through case studies, the possibility of developing a theory which integrates insights of Conceptual Semantics and those of Cognitive Linguistics.

This dissertation is organized into four parts. Part I begins by reviewing Jackendoff's (1990) lexical abbreviation analysis and pointing out its inadequacies. It is argued that a lexical network approach is more viable than a lexical abbreviation approach, and that the network consists of two sub-networks, i.e. a G(rammatical)-network and an S(ematic)-network. The G-network concerns phenomena that come under the label "argument structure alternations" in the generative lexical semantics literature, whereas the S-network is constituted by metaphor in the sense of Lakoff.

Part II examines in detail some of the phenomena falling within the realm of G-network. After showing the lexical extension approach to locative alternation (Rappaport and Levin 1988, Pinker 1989) to be untenable, chapter 2 proposes an alternative analysis based on the form-meaning correspondence model similar to "construction" proposed by Goldberg (1992a, 1992b).

In chapter 3, this form-meaning correspondence model is compared to the construction grammar approach. It is further shown that the model extends to other linguistic phenomena, like locative alternation with verbs of removal (3.2), denominal verbs (3.3), and causative alternation (3.4).

Chapter 4 explores how the motion sense (e.g. Amy went from Denver to Indianapolis.) and the extent sense (e.g. This road goes from Denver to Indianapolis.) are to be related. It is shown that the two semantic functions, i.e. GO and GO_{EXT},

proposed by Jackendoff for motion and extent senses, respectively, are related but distinct functions. It is further shown that the account based on semantic functions can handle phenomena that have so far attracted little attention.

Part III is concerned with S-network. Chapter 5 is devoted to an elucidation of metaphor and thematic relations by making explicit both similarities and differences between the two notions.

Chapter 6 reviews Jackendoff's (1992) claim that the thematic parallelism across semantic domains results from the interaction of an abstract organizing system with domain-specific properties, and then gives substance to this claim by exploring the inherent domain structures of the three non-spatial domains (temporal, possessional, and identification-al). It is shown that the domain-specific properties account for both parallels and non-parallels across domains.

Part IV is devoted to case studies. Chapter 7 shows that multiple senses of pass can be profitably accounted for in terms of the mechanisms already examined: viz. metaphor and GO_{Ext}. Yet other mechanisms are shown to be necessary in the course of discussion, like a reflexive path, profile shift (chapter 8), an image-schema transformation (chapter 9), metonymy and active zones (chapter 10).

While this study takes Jackendoff's (1990) analysis as a starting point and uses formalism of Conceptual Semantics, it is not intended to be either exclusively in the generativist camp or exclusively in the cognitivist camp. As the reader can easily see in Part IV, the lexical network approach proposed in this dissertation is a synthesis of Conceptual Semantics and Cognitive Linguistics.

PART I
Two Kinds of Network

Chapter 1

Multiple Conceptual Structures of a Single Verb: Lexical Abbreviation or Lexical Network?

1.0. Introduction

Quite often, a single verb exhibits a number of different but related senses. In order to treat the multiple senses properly, the theory of lexicon has to determine (1) whether just one entry is sufficient to accommodate them or multiple lexical entries are needed, and (2) how the relatedness among the senses should be captured.

While few serious attempts have been made to address these questions, one possibility is suggested in Jackendoff (1990).

an important problem for the theory of the lexicon ...
is how to unify related uses of a lexical item into a
single entry. (Jackendoff 1990:71)

As this passage clearly shows, Jackendoff tries to collapse multiple senses into a single entry, on the assumption that the relatedness among the senses can be formally expressed in conceptual structure.¹

In the following discussion, I challenge this view. A thorough examination of a particular verb reveals that different senses cannot be unified into a single entry, and instead call for different entries.

1.1. Lexical Abbreviation Analysis

1.1.1. Jackendoff (1990)

Jackendoff's (1990:143-144) lexical abbreviation analysis of hit covers the three senses in (1).²

- (1) a. Sue hit Fred.
- b. The car hit the tree.

c. Pete hit the ball into the field.

The hit in (1b), which is the simplest, is represented as in (2).

(2) The car hit the tree.

[INCH[BE_c([CAR],[AT_c[TREE]])]]

INCH is an operator which maps a State into an Event culminating in that State. c stands for "contact". Thus (2) conveys the car's coming into contact with the tree.

Next, (1a) is represented as in (3) (Irrelevant details are omitted in order to facilitate presentation).

(3) Sue hit Fred with a stick.

[CS⁺([SUE],[INCH[BE_c([STICK],[AT_c[FRED]])]])]

The main function CS⁺, meaning CAUSE, takes SUE as its first argument, and INCH as its second argument. The superscript + concerns a "success parameter", indicating application of force with a successful outcome (Jackendoff 1990:132). STICK is written inside the first argument slot of the embedded BE, because what comes into contact with Fred is the stick.

Finally, (1c) is represented as in (4).

(4) Pete hit the ball into the field <with a stick>.

[CS_{launch}⁺([PETE],[GO([BALL],[TO[IN[FIELD]])]])]
[BY[CS⁺([PETE],[INCH[BE_c([<STICK>],[AT_c[BALL]])]])]]

The main clause means that Peter caused the ball to go into the field, with the subordinate BY clause indicating that this causative event is mediated by Peter's striking a stick against the ball.

Jackendoff maintains that the sense of hit in (2), i.e. that of an object coming in contact with another object, is

the core conceptualization of the verb hit. The sense of hit in (3) elaborates (2) by adding an outer CAUSE (=CS⁺). The sense of hit in (4) elaborates (3) by adding to it still another CAUSE (=CS_{1launch}⁺). In other words, the three senses of hit are the core (2), an outer elaboration (3), and a second layer of outer elaboration (4).

Jackendoff suggests that a notational device can unify the three senses.

The two elaborations together can be combined in the lexical entry of hit, using a double application of the dashed underline notation of section 4.1, suitably generalized. (p.144)

A dashed underline indicates that the material is optional, thereby making it possible to combine multiple conceptual structures. One putative application of this notation to verbs is the causative alternation. Thus the two conceptual structures (6a) and (6b), which correspond to (5a) and (5b), respectively, are unified into (7).

- (5) a. The box slid down the stairs.
 b. Bill slid the box down the stairs.
- (6) a. [Event GO([Thing]₁, [Path]_k)]
 b. [Event CAUSE([Thing]₁,
 [Event GO([Thing]₁, [Path]_k)])]
- (7) [Event CAUSE([Thing], [Event GO([Thing], [Path]_k)])]]

While Jackendoff does not show what the abbreviated entry of hit looks like, the idea expressed in the above quote is implemented by (8), which expresses the three senses in (9).

- (8) [CS_{1launch}⁺(A, GO(B, TO IN C))]
 [BY[CS⁺(A, INCH[BE(D, AT B)])]]]

- (9) a. D hit B. (=1b)
 b. A hit B. (=1a)
 c. A hit B into C. (=1c)

1.1.2. Inadequacies

Jackendoff's analysis amounts to the claim that relations among different senses are purely formal, and that the different senses can therefore be combined by means of formal devices. While seemingly successful, this analysis has a couple of problems. First, his analysis is concerned with spatial senses alone and cannot be easily extended to non-spatial senses. Thus consider (10).

(10) She hit him with bitter words.

Clearly this sense is a non-spatial counterpart for the sense of hit in (1a). A usual strategy taken to capture a cross-field parallelism is to keep the functional structure intact between the two senses,³ so that the conceptual structure for (10) should have the same functional structure as (3), repeated here as (11).

(11) Sue hit Fred with a stick.

[CS⁺([SUE],[INCH[BE_c([STICK],[AT_c[FRED]]))]]]

Notice, however, that in (11) the stick, an Instrument, functions as a Theme as well. If the functional structure is identical across the two senses, then words should count as a Theme in (10). But saying that words moved to him in (10) does not convey the correct meaning.

Next, even within the spatial domain the data coverage is insufficient. There seems to be no reason to exclude the sense of hit in (12) from consideration.

(12) I hit the hammer against the fence.

Moreover, the above analysis misses a distinction masked by surface syntax. Grunau (1985) observes that (13a) is ambiguous, in that hammer can be read as a theme synonymously with (13b) or as an instrument.

- (13) a. I hit the anvil with the hammer.
b. I hit the hammer against the anvil.

(Grunau 1985:153)

Grunau calls the two readings the impinging-theme reading and the instrument reading, respectively, and notes their syntactic and semantic differences.

First, in the instrument reading the entity denoted by the with-phrase is held throughout the action, while in the impinging-theme reading this is not the case.

- (14) a. I hit John with a bullet.
b. I hit John with a stick. (Grunau 1985:154)

(14a) strongly prefers an impinging-theme reading. To obtain an instrument reading, it must be assumed that I was holding the bullet in my hand and striking John with it. On the other hand, both readings are available for (14b): In the instrumental reading, we interpret the stick as being in my hand; in the impinging-theme reading, we interpret the stick as being thrown.

Grunau further argues that all impersonal "agents" as in (15a) are impinging-themes, and that (15b) is acceptable only in the interpretation where the stick was thrown.

- (15) a. The bullet hit John.
b. *The stick hit John. (Ibid.)

Next, Grunau observes that (16a), where the impinging-theme with-phrase precedes the instrument with-phrase, is better than (16b), where the two with-phrases are in the reverse order.

- (16) a. I hit the target with a well-placed arrow with John's bow.
b. *I hit the target with John's bow with a well-placed arrow. (ibid.)

Grunau argues that this is because the impinging-theme with-phrase is at a lower projection than the instrument with-phrase.

In addition to Grunau's observations, a couple of behavioral differences support the distinction between the two readings. Only the instrument reading has a corresponding passive as in (17a). (17b) is just unintelligible.*

- (17) a. John was hit with a stick.
b. *John was hit with a bullet.

Moreover, both instrument and impinging-theme with-phrases will only support their own respective readings after do-so.

- (18) a. I hit John with a stick, and Mary did so with a hammer.
b. I hit John with a bullet, and Mary did so with an arrow.

If we mix the two kinds of with-phrases, the resulting sentences are anomalous, in either order (instrument + impinging-theme (19a), impinging-theme + instrument (19b)).

- (19) a. *I hit John with a stick, and Mary did so with a bullet.

- b. *I hit John with a bullet, and Mary did so with a stick.

All this indicates the need to distinguish the two readings, although Jackendoff identifies the V NP with NP string with a single sense.

Consequently, we have five hits in the spatial domain, exemplified in (20). For convenience, let us henceforth refer to them as hits (A), (B), (C), (D), and (E).

- (20) a. He hit the fence. (A) (=1a)
b. He hit the fence with a bullet. (B)
c. He hit a stick against the fence. (C)
d. A bullet hit the fence. (D) (=1b)
e. He hit the ball into the field. (E) (=1c)

Hit (B) and hit (C) are left out of Jackendoff's analysis. Examining these five senses will show whether the lexical abbreviation analysis works or not.

1.2. Analysis

1.2.1. Five Hits

Hit (D) means that an object comes forcefully into contact with a place, suggesting that it can be analyzed as a GO-verb with the following conceptual structure.

- (21) A bullet hit the fence. (D)
[GO([BULLET],[TO FENCE])]

In hit (C) the against-PP cannot be omitted without substantial meaning change, as Fillmore (1977) observes.

- (22) a. I hit the cane against the fence.
b. ≠I hit the cane. (Fillmore 1977:96)

Besides, this PP falls inside do-so.

- (23) John hit a stick against the fence, and Bill did so, too.

From these observations, I take this PP to be an argument. Hit (C) essentially means that an object designated by the direct object comes into contact with a place denoted by the PP, and the subject NP stands for an instigator. Thus its representation is (24).

- (24) He hit a stick against the fence. (C)
[CAUSE([HE],[GO([STICK],[TO FENCE]])]]

In hit (B), the impinging-theme reading, an object designated by the with-PP comes into contact with a place denoted by the direct object. Its representation is thus (25).

- (25) He hit the fence with a bullet. (B)
[CAUSE([HE],[GO([BULLET],[TO FENCE]])]]

Hit (A) may also take a with-PP, but this PP is instrumental and not an argument. Omitting this PP does not result in ill-formedness or in substantial meaning change, as it would in hit (B).

- (26) a. He hit the fence with a stick.
b. He hit the fence.

Thus only subject and direct object NPs count as arguments.

This might appear to pose a problem for thematic analysis. Unlike other hits, none of the argument NPs of hit (A) is asserted to move: Neither subject nor direct object NP can be construed as undergoing motion as in other cases, so

thematic analysis appears to fail.

This apparent difficulty can be overcome by recourse to lexical decomposition. Notice that hit (A) can be paraphrased as "to give an impact to". On this basis, we get the following representation.

- (27) He hit the fence. (A)
[CAUSE([HE],[GO([IMPACT],[TO FENCE]])]]]

Three argument slots are available in conceptual structure, although only two of them correspond to syntactic positions.

Finally, let us turn to hit (E), which is represented as in (28).

- (28) He hit the ball into the field.
[CAUSE([HE],[GO([BALL],[TO IN FIELD]])]]]
[BY[CAUSE([HE],[GO([IMPACT],[TO BALL]])]]]

(28) means that he hit the ball, thereby causing it to go into the field.

1.2.2. Relations between Hits

Let us now examine how the five hits are related. First compare hits (A) and (B). Section 1.1.2. stressed their distinctness, yet they are related as well: They both have CAUSE-GO in conceptual structure. In fact, their relatedness is reinforced by the following consideration.

Recall that the object denoted by the with-PP of hit (B) must be something that comes suddenly and forcefully of its own force, such as a bullet or an arrow. When an object that is not readily so interpreted (e.g. a stick) appears in the with-PP, it tends to be reinterpreted. Notice that this is the effect of selectional restriction, which is accommodated in Conceptual Semantics as a semantic marker inside a conceptual argument position (See Jackendoff 1987, 1990).

Thus IMPACT is written inside the first argument slot of the embedded GO, and the lexical entry for hit (B) will be (29).

(29) $\left[\begin{array}{l} \text{hit (B)} \\ [-N,+V] \\ \text{--- NP}_1 \text{ <with NP}_k \text{>} \\ [\text{CAUSE}([\text{THING }]_1, [\text{GO} ([\text{IMPACT}]_k, [\text{PATH TO}([]_1)])])] \end{array} \right]$

The third and fourth rows express syntactic and semantic /conceptual information, respectively. The subscripts indicate correspondences between syntactic and conceptual positions. Thus the index k relates the NP after with and the first argument of the embedded GO, indicating that the NP subscripted with k must be an impinging-theme.

Now the semantic parts of the lexical entries for hits (A) and (B) are identical except for their syntactic co-indexes.

(30) a. $[\text{CAUSE}([\text{THING }]_1, [\text{GO} ([\text{IMPACT}], [\text{PATH TO}([]_1)])])]$: (A)
 b. $[\text{CAUSE}([\text{THING }]_1, [\text{GO} ([\text{IMPACT}]_k, [\text{PATH TO}([]_1)])])]$: (B)

They both have IMPACT in the first argument position of the embedded GO, but only (A) indexes that position. That is, with hit (A) IMPACT is an incorporated argument, whereas with hit (B) it serves as a selectional restriction.

Next, observe the contrast between hits (A) and (B) on the one hand and hit (C) on the other in regard to syntactic expression of internal arguments. The direct object NP is a Place with the former, but a Theme with the latter. Thus these senses exhibit complement alternation.

Notice that it is quite common for a single verb to alternate between complement structures that express nearly

identical thematic relations. A well-known class of verbs called locative alternation verbs are a case in point.

- (31) a. Bill loaded hay onto the truck.
b. Bill loaded the truck with hay.

The relationship between hits (A) and (B) and hit (C) is parallel to this alternation. The same mechanism seems to be at work in both cases.

Let us turn to hit (D). As seen in 1.1.2., the subject NP must be an impinging-theme, so that the first argument position of GO contains IMPACT. As just seen above, IMPACT appears in the first argument position of the embedded GO with hits (A) and (B). Probably the same is true of hit (C), which, Grunau argues, is synonymous with hit (B). As a consequence, relevant parts of the conceptual structures are the following:

- (32) a. [CAUSE([], [Event GO([IMPACT], [])])]: (A), (B), (C)
b. [Event GO([IMPACT], [])] : (D)

Hit (D) has a GO, while the other three senses have a CAUSE which embeds a GO as its second argument. Remarkably, the GO-function is identical across the senses: It is eventive and its first argument position has IMPACT inside it.

Here again, this relationship is not unique to hit. The contrast in (32) reminds us of causative-ergative pairs, where a class of verbs called ergatives alternate between monadic and dyadic uses. Sink is a good example (A boat sank/John sank the boat). The transitive can be analyzed as a causative of the intransitive. That is, the intransitive is embedded as a complement of the transitive in conceptual structure.

Although ergatives have monadic and dyadic valencies, and hit has dyadic and triadic ones, the parallel is clear. In

both cases, a single verb has multiple senses, one of which is a causative of another in conceptual structure.

The parallel holds morphologically as well. The switch from causative to ergative (or the other way round) brings about no morphological changes (crack/crack, open/open, tighten/tighten, drop/drop, etc. See Hale & Keyser 1986). And, of course, the four senses of hit are all of the same form.

Thus the relationship observable in (32) parallels that linking the causative-ergative pair. Probably a general process (either causativizing or decausativizing) is operative in the lexicon, relating the multiple uses. The transitivity alternations which ergatives and middles exhibit are particular instances of this process.

Finally, let us turn to hit (E). This sense is what Jackendoff (1987:70) calls a spatial resultative, where addition of a Path-expression creates a sense of movement which is not a necessary component of the verb meaning. Again, spatial resultatives are available for quite a sizable number of verbs. Sentences in (33) are paraphrased in (34).

- (33) a. Bill pushed the piano into the orchestra pit.
b. Beth wiggled the tooth out of her mouth.
c. The critics laughed the show out of town.

- (34) a. Bill made the piano go into the orchestra pit by pushing (on) it.
b. Beth made the tooth come out of her mouth by wiggling it.
c. The critics got the show out of town by laughing (at it). (Jackendoff 1987:70)

We have thus far seen that the five senses of hit are related through general processes. The relationships are described as in Fig. 1.

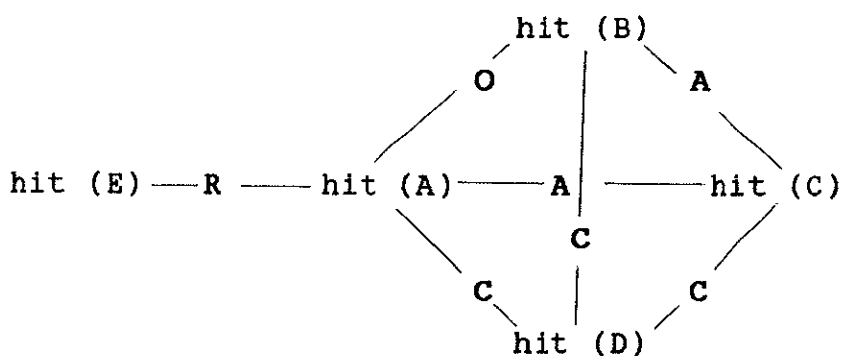

C: causative-pair O: optional mapping
 A: complement R: spatial resultative
 alternation

Fig. 1

1.2.3. Further Senses

Let us now return to the sense of hit in (10), repeated here as (35), which will be referred to as hit (F).

(35) She hit him with bitter words. (F)

As I pointed out in 1.1.2., Jackendoff's analysis cannot be naturally extended to handle hit (F) in a way parallel to hit (A), despite their clear relatedness.

My analysis can straightforwardly accommodate hit (F). Hit (A) is represented as in (36), based on the paraphrase "to give an impact to".

(36) He hit the fence. (A)
 [CAUSE([HE],[GO([IMPACT],[TO FENCE]))]]

Note that hit (F) can be similarly paraphrased as "to give a mental impact to", thus leading to the conceptual structure in (37).

(37) She hit him with bitter words.
 [CAUSE([SHE],[GO([MENTAL IMPACT],[TO HIS MIND]))]]

This analysis relates the two senses just as Conceptual Semantics often achieves a lexical generalization: The two hits share a functional structure, differ only in whether that function is applied to the spatial domain or to the psychological domain.

Because the two domains have different ontologies, the two senses take different entities as arguments. Consequently, the relationship between the two senses can be characterized as a domain shift from spatial to psychological with concomitant changes of arguments, as in (38).⁵

(38)	Spatial		Psychological
	person	—>	percept
	physical impact	—>	mental impact
	concrete place	—>	human mind

This analysis, besides being capable of achieving a lexical generalization, is significant in indicating that further senses can be accounted for by applying the functional structure to different domains. This leads us to expect that the same holds true of spatial senses other than hit (A).

This prediction is in fact borne out. Let us consider hit (D), which is a GO-verb.

(39) [GO([X],[TO Y])]

As already seen, hit (D) means that X comes suddenly and forcefully into contact with Y, where X is a thing and Y a place. When shifted into the psychological domain, it comes to mean "to come suddenly to the mind of", as exemplified in (40).

(40) When did it first hit you that you nearly died? (G)

(Reader's Digest. May.1989)

X is an idea or thought and Y a human mind. This sense will be referred to as hit (G).

The following sense, hit (H), meaning "to affect very badly", is also an extension of hit (D).

- (41) In May a typhoon hit the Phillippines. (H)
(COBUILD)

X is a disaster, a disease, an illness, etc. and Y people or an area.

It might appear that hit (H) is an extension of hit (A) rather than hit (D). Indeed hits (A) and (D) are identical in form (NP V NP), and it seems difficult to tell which of the two senses hit (H) is related to. Yet one piece of evidence that hit (H) is related to hit (D) comes from deletability of direct object. Hit (D), but not hit (A), allows object deletion, as Fillmore (1968) observes.

- (42) a. The bullet hit.
b. *Peter hit. (Fillmore 1968)

Hit (H) allows object deletion.

- (43) In May a typhoon hit.

It thus seems correct to hold hit (H) as related to hit (D).⁶

Now when Y is some element of the communication media, what comes into contact with Y naturally becomes public. Hence the meaning "to appear", as exemplified in (44).

- (44) a. [It] did not hit the newspapers until August.
b. No wonder these stories hit the front page of

The New York Times.

- c. "... the story hit the national wires. ..."
- d. ... the ads hit newspapers, TV and billboards.

(Ruhl 1989:111)

This sense will be referred to as hit (I). Y may also be shops (45a) or markets (45b), which constitute a public sphere.

- (45) a. Time's edition hit the newsstands.
- b. Sweet corn hits the market in New England in midsummer. (ibid.)

Some instances of hit up to this point treat a person as Y, i.e. some kind of abstract place (e.g. hit (G) and hit (H)). Yet it is also possible for a person to be X, i.e. some sort of moving object. Thus in (46) the sense of encounter emerges, and hit comes to mean "to reach, arrive at, find". This sense will be referred to as hit (J).

- (46) We hit the main road two miles further on. (OALD)



Fig. 2

While hit (J) involves a spatial movement, it can be further extended into an abstract domain. The sense of hit in (47), referred to as hit (K), can be also paraphrased as "to reach", but in an abstract sense.

- (47) The new train can hit 150 mph.

This sense takes a linear scale as a Path, and in (47) the

train is asserted to reach a particular point on this Path.

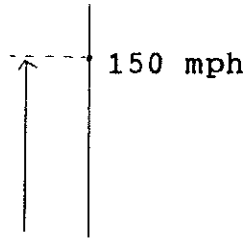

Fig. 3

Hit (K) may take as a Path those related to a linear scale like time (48a), or a stage (48b).

(48) a. The Redskins need to hit the league season with everyone healthy.

b. He's hit the stage of incredible enthusiasm.

(Ruhl 1989:110)

We have so far seen extensions of hit (A) and hit (D), whose relationships are summarized as in Fig. 4.

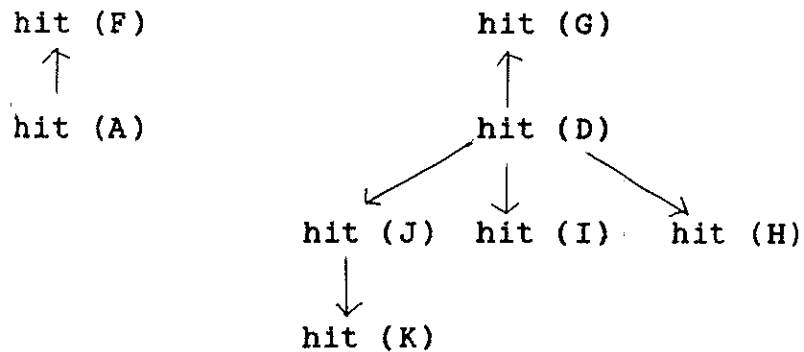

Fig. 4

By combining Fig. 4 with Fig. 1, we get Fig. 5.

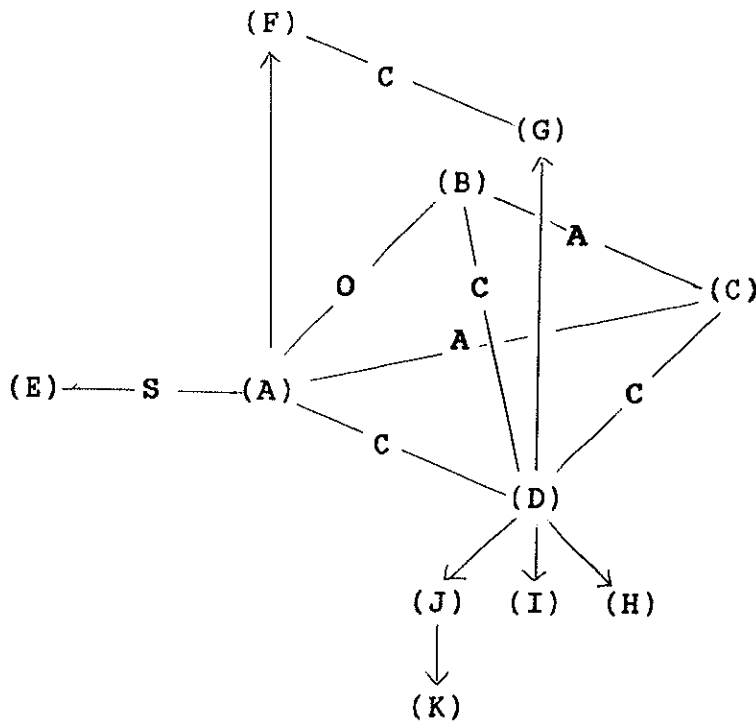

Fig. 5

1.3. Grammatical and Semantic Networks

The last section has shown that various senses of hit form the complex network in Fig. 5, comprising two networks, a Grammatical (G-) Network in the horizontal plane linking the senses in 1.2.1., and a Semantic (S-) Network in the vertical plane which links those in 1.2.2.

1.3.1. G-Network

The G-network covers what is called "argument structure alternations" in the literature (Hale & Keyser 1986, Lévin & Rapoport 1988, Levin & Rappaport 1988, Pinker 1989, Levin 1993, among others). Recall that in 1.2.1. the five senses are differentiated by semantic function or indexing: (a) how many arguments each sense requires, and (b) how the arguments are syntactically realized, "lexical properties" in GB theory.

1.3.2. S-Network

The S-network is characterized by domain shift, which subsumes metaphorical mapping (Lakoff & Johnson 1980, Lakoff 1987, 1990, 1992, 1993, Norvig & Lakoff 1987) and also what the Thematic Relations Hypothesis (Jackendoff 1983) is intended to capture.⁷ Thus each link between the senses can be regarded as a metaphor in the sense of Lakoff. In fact, the following metaphor is just the link between hits (A) and (F).⁸

(49) EMOTIONAL EFFECT IS PHYSICAL CONTACT

His mother's death hit him hard. That idea bowled me over. She's a knockout. I was struck by his sincerity. That really made an impression on me. He made his mark on the world. I was touched by his remark. That blew me away.

(Lakoff and Johnson 1980:50)

Lakoff (1990, 1992) argues that a metaphorical mapping includes both ontological and epistemic correspondences: The former maps entities, and the latter a knowledge structure, across conceptual domains. In conceptual structure a la Jackendoff the number of arguments (i.e. participants in an event) is explicit, and in this sense the representation makes the ontological correspondences explicit.⁹

1.4. The Necessity of Network

We are now in a position to tell whether the lexical abbreviation analysis is tenable or not. Our investigation indicates that it is practically impossible to unify multiple senses of hit into a single entry. The dashed underline notation, which Jackendoff uses in relating the three senses (i.e. (A), (D), and (E)), is not capable of handling hit (B) or hit (C).

One might argue that hits (B) and (C) can be accommodat-

ed by introducing new notational devices. But even if one succeeds in concocting such devices to unify into one entry the senses in the G-network, the notational trick won't work for the senses in the S-network. There seem to be no general principles that predict extensions in the S-network.

In what follows, we will see further arguments for a network approach.

1.4.1. Strike

1.4.1.1. G-Network

Strike is certainly very similar to hit, but the two verbs are not identical. First, Jackendoff (1987) observes that the spatial resultative sense is not available for strike.

- (50) a. The car struck the tree.
b. Sue struck Fred with the stick.
c. *Pete struck the ball into center field
(with a stick). (Jackendoff 1987:402)

Next, recall that when hit appears in the V NP with NP string, the with-PP is ambiguous between instrument and impinging-theme readings.

- (51) a. I hit John with a stick. (=instrument)
b. I hit John with a bullet. (=impinging-theme)

But the impinging-theme reading is not available for strike.

- (52) a. I struck John with a stick.
b. *I struck John with a bullet.

The with-PP is exclusively an Instrument. It can be omitted without affecting grammaticality.

- (53) a. He struck the fence with a stick.
 b. He struck the fence.

Moreover, the with-PP appears after do-so (54a) and can be topicalized (54b).

- (54) a. John struck Mary with that hammer, and Bill did so with another hammer.
 b. With that hammer, I believe he struck Mary.

(Oka 1986:141-46)

(Oka (1986) analyzes the with-PP of strike as adjunct within the framework of GB syntax. For details, see Oka (1986).)

Thus while hit has five senses in the spatial domain, two of them are lacking in strike. The remaining three senses are available for strike, as exemplified in (55).

- (55) a. He struck the fence. (A)
 b. He struck a stick against the fence. (B)
 c. A bullet struck the fence. (C)

Strike (C) is analyzed as a GO-verb and is represented as in (56).

- (56) A bullet struck the fence. (C)
 [GO([BULLET],[TO FENCE]])

Strike (B) takes an against-PP, which counts as an argument. It cannot be omitted without substantial meaning change (57), and it falls inside do-so (58).

- (57) a. He struck a stick against the fence.
 b. *He struck a stick.
 (58) John struck a stick against the fence, and Bill did so, too.

Therefore, strike (B) is represented as in (59).

- (59) He struck a stick against the fence. (B)
 [CAUSE([HE],[GO([STICK],[TO FENCE]))]]

Finally, strike (A) can be lexically decomposed as "to give an impact to", yielding the conceptual structure in (60).

- (60) He struck the fence. (A)
 [CAUSE([HE],[GO([IMPACT],[TO FENCE]))]]

Let us examine the relationships between the three senses. Strikes (A) and (B) are causatives of strike (C), as shown in (61).

- (61) a. [CAUSE([],[Event GO([IMPACT],[])]): (A),(B)
 b. [Event GO([IMPACT],[])] : (C)

Strike (A) and strike (B) exhibit a complement alternation: The former realizes a Place, and the latter a Theme, as direct object. Consequently, the relationships are described as in Fig. 6.

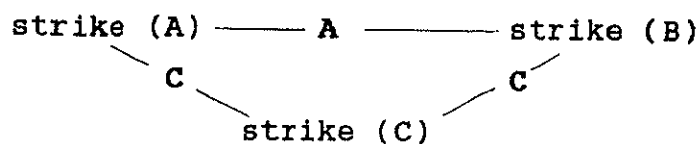

A: complement alternation C: causative-pair

Fig. 6

1.4.1.2. S-Network

The conceptual structure of strike (A) is roughly as in (62), where X is a person and Y a place.

(62) [CAUSE([X],[GO([IMPACT],[TO Y]])]]

When shifted into the psychological domain, (62) comes to mean "to give a mental impact to, to impress".

(63) What he said really struck me.
[CAUSE([WHAT HE SAID],
[GO([MENTAL IMPACT],[TO MY MIND]])]]

This sense will be referred to as strike (D).

Now consider the following, which will be referred to as strike (E).

(64) John strikes me as being honest.

Note the affinity between strike (D) and strike (E). Syntactically they both take a human NP as direct object, their difference being the presence vs. absence of as-PP. Semantically they can be paraphrased as "to give a mental impact to one's mind", and "to give a particular impression to one's mind", respectively, suggesting the possibility of analyzing them by means of the same function. Consequently, strike (E) is represented as in (65).

(65) John strikes me as being honest.
[CAUSE([JOHN_i],[GO([i HONEST],[TO MY MIND]])]]

Both strikes (D) and (E) indicate the transmission of a mental object to a human mind, a mental impact with the former and a particular impression with the latter. The mental object appears in the first argument position of the embedded GO, which is an incorporated argument with the former and is realized by the as-PP with the latter (See Iwata 1988, 1989).

Let us now turn to strike (C), which is a GO-verb and which has extensions parallel to those of hit (D).

(66) [GO([X],[TO Y])]

When the functional structure in (66) is applied to the psychological domain, it comes to mean "to come suddenly to the mind of".

- (67) a. An idea struck me. (= An idea occurred to me)
b. It struck me that John would win.

This sense will be referred to as strike (F).

When something unpleasant like an illness or a disaster is construed as a kind of moving object, the meaning becomes "to affect very badly".

(68) The earthquake struck Fiji last Tuesday.

This sense will be referred to as strike (G).

Finally, when a person is construed as a moving object, the meaning "to reach" obtains, which will be referred to as strike (H).

(69) We've struck the road. (LDCE)

The relationships are expressed as in Fig. 7.

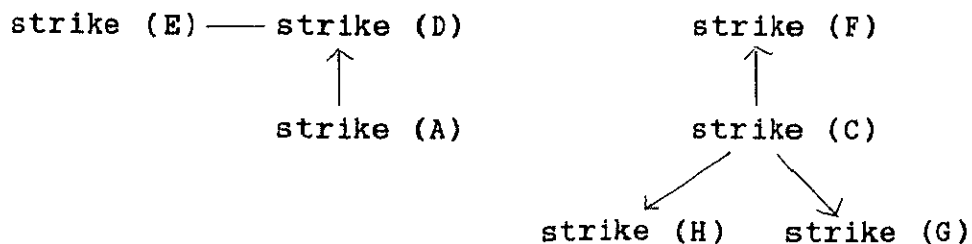

Fig. 7

1.4.1.3. The Overall Network of Strike

We have so far seen eight senses of strike. Their relationships are described by Figs. 6 and 7, but not completely. Consider once again strikes (D), (E), and (F), which can be collectively called 'psychological strikes'. The lexical entries for strikes (D) and (E) will be (70) and (71), respectively.

- (70) $\left[\begin{array}{l} \text{strike (D)} \\ [-N, +V] \\ \text{--- NP}_1 \\ [\text{state CAUSE}([\]_1, [\text{Event GO}([\text{IMPACT}], \\ \text{[Path TO}([\]_1)])])] \end{array} \right]$
- (71) $\left[\begin{array}{l} \text{strike (E)} \\ [-N, +V] \\ \text{--- NP}_1 \text{ as XP}_k \\ [\text{state CAUSE}([\]_1, [\text{Event GO}([\]_k, \\ \text{[Path TO}([\]_1)])])] \end{array} \right]$

Strikes (D) and (E) differ as to the syntactic realization of the first argument of GO. This conceptual position is unindexed with the former but is related to an as-PP by k with the latter.

Next, strike (F) is a GO-verb, and strikes (D) and (E) embed GO as the second argument of CAUSE. In this sense, strikes (D) and (E) can be said to be causatives of strike (F). Consequently, the relationships between the three senses are described as in Fig. 8.

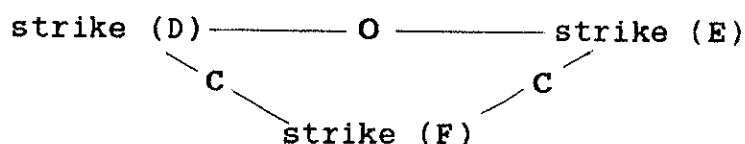

Fig. 8

Now Figs. 6, 7, and 8 are combined into Fig. 9.

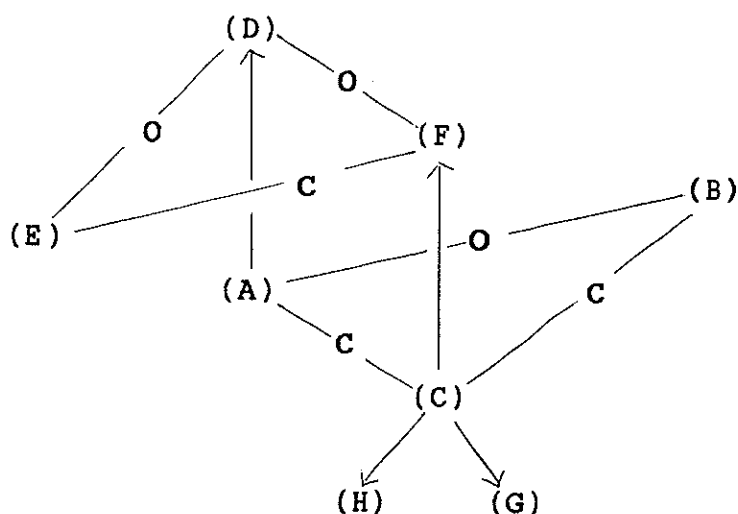

Fig. 9

Remarkably, the network of strike is not identical to that of hit. That hit and strike, which appear to be nearly synonymous, should exhibit different networks indicates that it seems quite difficult, if not impossible, to predict the entirety of senses from a single sense. Different senses need to be specified in the lexicon in any way, suggesting the futility of the lexical abbreviation analysis.

1.4.2. Japanese

In this section I will consider Japanese counterparts for hits and strikes. Let us start with G-network senses of hit. Japanese has several verbs of physical impact that are often used to translate hit: utsu, butsu, tataku, naguru, ateru, and butsukeru. They appear in the following syntactic frames.¹⁰

- (72) a. Taro-wo (sutekki-de) { utsu (butsu)
 acc. stick instr. | tataku
 | naguru

- | | | |
|--|--|------------|
| | | *ateru |
| | | *butsukeru |
- 'hit Taro (with a stick)'
- | | | | |
|----|------------|---------|----------------|
| b. | Sutekki-wo | Taro-ni | *utsu (*butsu) |
| | stick | acc. | *tataku |
| | | loc. | *naguru |
| | | | ateru |
| | | | butsukeru |
- 'hit a stick against Taro'

Japanese marks grammatical relations by means of particles or postpositions. (72a) and (72b), where wo marks direct object, correspond to V NP₁ with NP₂ and V NP₂ against NP₁ frames, respectively. In (72a) direct object Taro expresses a target place and an instrumental phrase sutekki-de (with a stick) optionally appears. On the other hand, in (72b) direct object sutekki (a stick) expresses a Theme, with the oblique phrase Taro-ni indicating the target place. Thus verbs that are acceptable in (72a) and (72b) correspond to hit (A) and hit (C), respectively.

The counterpart for hit (D) is (73), where the Theme bohru (a ball) is marked by a nominative marker ga.

- (73) bohru-ga kabe-ni ataru.
 ball nom. wall loc. butsukaru.

'A ball hit the wall.'

Hit (B) and hit (E) can be translated as (74) and (75), respectively.

- (74) mato - wo ataru
 target acc.
 'hit the target'

- (75) bohru-wo sentaa-e uchi-tobasu
 ball acc. center to hit make-fly
 'hit and make-fly a ball into center field'

The correspondences are summarized as in (76).

- (76) (A): utsu(butsu), tataku, naguru
 (B): ateru
 (C): ateru, butsukeru
 (D): ataru, butsukaru
 (E): uchi-tobasu

Remarkably, the semantic relationships between the five senses of hit are overtly expressed in the Japanese counterparts. Verbs corresponding to hit (C), ateru and butsukeru, are morphologically related to those to hit (D), ataru and butsukaru. In fact, the vowel change a/e is often a marker of causative pair, making explicit the semantic relationship. This is not the case with verbs corresponding to hit (A), which lack such morphologically related variants. Instead, they can be all paraphrased by 'shougeki-wo ataeru', literally 'to give an impact'. Thus these verbs can be regarded as incorporating IMPACT in conceptual structure. And the Japanese counterpart for hit (E), which is a spatial resultative, is a complex verb uchi-tobasu, literally 'to hit and make-fly', again reflecting the complex conceptual structure for hit (E).

Let us turn to S-network senses. The sentences in (76) are Japanese counterparts for hit (F).

- (77) a. Taro-no - kokoro-wo utsu.
 gen. mind acc.
 'hit Taro's mind'
- b. kokoro-ni seishinteki-shougeki-wo ataeru
 mind loc. mental impact acc. give

'give a mental impact to one's mind'

(77a) is the most straightforward translation of hit (F), consisting of utsu along with kokoro 'mind'. Note that utsu is a counterpart for hit (A). Unlike hit, however, utsu requires the presence of kokoro 'mind' in order to express a psychological meaning. The same meaning can be also conveyed periphrastically as in (77b), where either kokoro or seishin-teki is necessary, and the whole expression directly reflects the conceptual structure for hit (F).

Japanese makes use of different verbs to express the meanings covered by hits (G), (H), and (I). The counterpart for hit (G) is ukabu 'to surface' as in (78), that for hit (H) osou 'to attack' as in (79), and that for hit (I) deru or arawareru, which are verbs of appearance, as in (80).

- (78) kangae-ga kokoro-ni ukabu
idea nom. mind loc. surface
'An idea surfaces to my mind'
- (79) taifu - ga sono-machi-wo osotta
typhoon nom. def. city acc.
'The typhoon attacked the city'
- (80) sono-kiji - ga shimbun - ni deta/?arawareta
def. story nom. newspaper in
'The story appeared in the newspaper'

The sense of hit (J) is conveyed by iki-ataru, literally 'to go and hit', or buttsukaru, a counterpart for hit (D).

- (81) shuyou-douro-ni iki-ataru/butsukaru
main road loc. go hit/hit
'go-hit/hit the main road'

Hit (K) can be translated by tassuru 'to reach'.

- (82) 150-kiro-ni tassuru
 kilo loc. reach
 'reach 150 Kph'

Now let us turn to strike. Many of the senses of strike are also available for hit, and it seems correct to match the senses of strike with Japanese verbs seen above to correspond to senses of hit. One sense that is available for strike but not for hit is strike (E). There seems to be no Japanese lexical verb that perfectly corresponds to strike (E). One must resort to a periphrastic expression in order to express the intended meaning.

- (83) Taro-wa shoujiki-da-to-iu-insho wo ataeru.
 nom. honest be comp. impression acc. give
 'Taro gives me an impression of being honest'

Insho-wo ataeru is literally 'to give an impression', again directly reflecting the conceptual structure for strike (E).¹¹

Now the overall correspondences are summarized in Table 1.

hit (A):	strike (A):	utsu, butsu, tataku, naguru
hit (B):		ateru
hit (C):	strike (B):	ateru, butsukeru
hit (D):	strike (C):	ataru, butsukaru
hit (E):		uchitobasu
hit (F):	strike (D):	kokoro-wo utsu, kokoro-ni shougeki-wo ataeru
	strike (E):	insho-wo ataeru
hit (G):	strike (F):	kokoro-ni ukabu
hit (H):	strike (G):	osou
hit (I):		arawareru, deru
hit (J):	strike (H):	iki-ataru, butsukaru
hit (K):		tassuru

Table 1

Japanese uses different verbs to express the meanings covered by hit and strike, and Japanese verbs tend to reflect the conceptual structures more directly than hit and strike.

The multiplicity of Japanese counterparts indicates that there is no logical necessity for the various senses to be encoded by one and the same verb (hit or strike), although they happen to be so in English. If there were, hit would have to have just a single counterpart in Japanese.

Thus there does not seem to be much point in attempting to collapse multiple senses into a single entry by notational tricks, as does the lexical abbreviation analysis.

1.4.3. Projection Principle

The distinction among the senses is supported by theoretical consideration as well. In the Extended Standard Theory framework, the interrelationship between lexical properties and syntax is regulated by the Projection Principle.

the projection principle ... states that lexical structure must be represented categorically at every syntactic level. (Chomsky 1986:84)

This principle ensures that lexical properties of a verb are unaltered in the course of a derivation.

The natural intuitive sense of this principle is that every syntactic representation (i.e., LF-representation and S- and D-structure) should be a projection of the thematic structure and the properties of subcategorization of lexical entries, similar but not identical requirements. (Chomsky 1981:36)

Notice that the Projection Principle draws a line between

two senses of a single verb. Given that the Projection Principle guarantees the identity of lexical properties in the course of a derivation, it follows that two uses of a given verb are to be treated as distinct senses if they have different lexical properties: "thematic structure and the properties of subcategorization". These properties are what distinguish among senses in the G-network: The thematic structure determines the arguments of a sense, and subcategorization properties determine their syntactic realization. In order to maintain the Projection Principle, therefore, the distinctions among the senses in the G-network cannot be neglected.

Unfortunately, in many cases distinctions among the senses and their relevance to the Projection Principle have gone unnoticed, leading to confusion. One instance of confusion is found in Chomsky's (1981) analysis of strike. Chomsky notes a complementary distribution of a reflexive and a pronominal in the as-phrase of strike: A reflexive can be coreferential with the subject, but not the direct object, while a pronominal can be coreferential with the direct object, rather than the subject.

- (84) John strikes Mary as angry at himself (*him, her, *herself). (Chomsky 1981:290)

In order to give a binding theoretic account of these facts, Chomsky assumes a clausal as-complement and takes strike to be a raising predicate as in (85).

- (85) John_i strikes Mary [t_i as angry at himself]
(Chomsky 1981:291)

However, this analysis immediately encounters a problem, as Chomsky himself seems to admit. The sentences in (86) contain non-referential expressions as the subject of the

embedded clauses: there in (86a), idiom chunks in (86b), and the weather it in (86c).

- (86) a. It strikes me that there is a hole in that argument.
b. It struck me that tabs were kept on Melvin.
c. It struck me that it $\left\{ \begin{array}{l} \text{snowed} \\ \text{was foggy} \end{array} \right\}$ in Vermont.
(Postal 1974:296)

If strike is truly a raising predicate, the raised versions of these sentences ought to be well-formed. But in fact they aren't.

- (87) a. *There strikes me as being a hole in that argument.
b. *Tabs struck me as having been kept on Melvin.
c. *It struck me as having $\left\{ \begin{array}{l} \text{snowed} \\ \text{been foggy} \end{array} \right\}$ in Vermont.
(Ibid.)

Chomsky himself uses these non-referential expressions as diagnostics to test the clausal structure, so the ill-formedness of (87) is indeed a serious problem for Chomsky.¹²

Yet from my viewpoint, the ill-formedness of (87) comes as no surprise. Notice that the strikes in (86) and those in (87), which Chomsky attempts to relate by the operation of raising, are actually different senses: Those in (86) are strike (F), and those in (87) strike (E), which have different conceptual structures.

- (88) John strikes me as honest. (E)
[CAUSE([JOHN_i],[GO([i HONEST],[TO MY MIND]])])
(89) It struck me that S. (F)
[GO([S],[TO MY MIND]])]

Crucially, with strike (E) the subject position is a theta-position, where non-referential expressions cannot possibly occur. Hence the ill-formedness of (87).

The failure of the raising analysis ultimately stems from the failure to recognize the distinction between the two strikes. Since the two senses have different thematic properties,¹³ they undergo different derivations, as shown in (90).

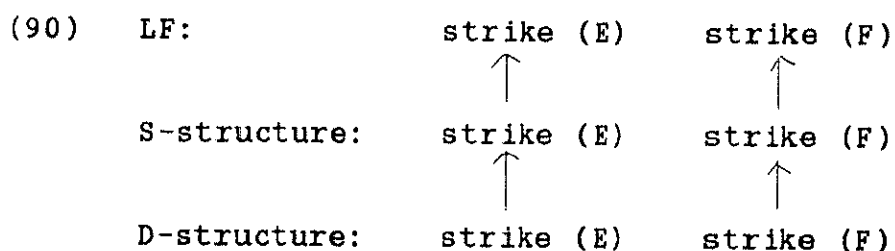

To recapitulate, distinctions with regard to lexical properties are essential to maintain the Projection Principle. Here again, distinctions among the senses are called for, but nothing requires the multiple senses to be collapsed into a single entry.

1.5. Concluding Remarks

It has been shown that multiple senses of a single verb form two kinds of network, i.e. G-network and S-network, which together constitute the overall network. A number of considerations argue for a network approach, rather than a lexical abbreviation analysis or its analogue.

In what follows, some of the links constituting G- and S-networks will be closely examined.

Notes to Chapter 1

1. Jackendoff uses the term 'use' to refer to the relevant distinctions. But I use the term 'sense', because the

distinctions in question are lexically significant.

2. Jackendoff (1987b) presents basically the same analysis of hit, which is open to the same criticisms as given in 1.1.2.

3. See Jackendoff (1987a:156).

4. I am indebted to Lynne Roecklein for this observation.

5. Professor Nakau has suggested this characterization.

6. This does not mean that deletability always counts as a reliable diagnostic, of course. It seems that the property concerning deletability is not preserved when the two domains are semantically distant. See Lakoff (1993).

7. This does not entail that metaphor and thematic relations are identical. Chapter 5 will discuss differences between these two notions.

8. Furthermore, examples in (44) can be characterized in terms of the conduit metaphor (Reddy 1979), and those in (47) and (48) in terms of the LINEAR SCALES ARE PATHS metaphor (Lakoff 1990).

9. One important difference between G- and S-networks is that the distinctions between S-network senses are not always clear-cut and are more difficult to determine.

10. There are subtle meaning differences among these verbs. The direct object is construed as a movable object with utsu, but as a stable place with tataku. Both butsu (a variant of utsu) and naguru are used to indicate causing damage to animate beings (cf. Kunihiro (1970)). Thus, naguru and butsu cannot occur in the following environment.

(i)	kabe	wo	(sutekki	de)	}	utsu
	wall	acc.	stick	with		tataku
						*naguru
						*butsu

'hit a wall with a stick'

11. Insho consists of two chinese characters in "mark" and sho "image". This is interesting in view of the fact that in English impress, which conveys a similar meaning, originally meant "to imprint".

12. Tanaka (1987) argues against this raising analysis, proposing that the underlying structure for the as-phrase consists of the preposition as and its clausal complement: [[PAS][S][NPPRO][INFLing][VP]]]. This seems to be a viable alternative. Note that this analysis, based on independent grounds, can also account for the binding facts by assuming a clausal structure. For details, see Tanaka (1987).

13. If we follow Jackendoff (1987, 1990) in defining thematic roles over structural configurations in conceptual structure (e.g. Theme as the first argument of GO, Causer as the first argument of CAUSE, etc.), then strike (E) takes Causer, Theme, and Goal roles, whereas strike (F) Theme and Goal roles. Or maybe the Experiencer is preferable over the Goal role.

PART II
G-Network

Chapter 2
Locative Alternation

2.0. Introduction

A class of verbs called locative alternation verbs exhibit two variants, a locative variant and a with variant in the terms of Rappaport & Levin (1988).

- (1) a. Jack sprayed paint on the wall. (locative variant)
- b. Jack sprayed the wall with paint. (with variant)
- (2) a. Bill loaded cartons onto the truck.
- b. Bill loaded the truck with cartons.

It is widely accepted in the literature that the locative variant denotes a change of location, and the with variant a change of state. The contrast between the two becomes clear when adverbials are added. The locative variant, but not the with variant, is compatible with one by one as in (3), while the with variant, but not the locative variant, can be modified by up in the perfective sense as in (4).

- (3) a. The boy loaded the boards one by one onto the wagon.
- b. *The boy loaded the wagon with the boards one by one.
- (4) a. He loaded up the wagon with the goods.
- b. *He loaded up the goods onto the wagon.

(Fraser 1971:607)

The locative alternation has attracted much attention because of a number of characteristics.¹ The following discussion is concerned with the very question of why a single verb appears in more than one syntactic frame.

2.1. Previous Studies

2.1.1. Rappaport and Levin (1988)

Rappaport and Levin (1988) posit the semantic structures in (5), where (5a) is for a locative variant and (5b) for a with variant.

- (5) a. LOAD: [x cause[y to come to be at z]/LOAD]
b. LOAD:
[[x cause[z to come to be in STATE]] BY MEANS OF
[x cause [y to come to be at z]]/LOAD]

Crucially, (5a) is embedded under BY MEANS OF in (5b), meaning that a change of state is brought about by means of a change of location. In other words, a with variant is an extension of a locative variant, the main clause of (5a) becoming a subordinate clause in (5b).

This analysis raises a number of problems. First, it ensures only deriving the with variant from the locative variant, but another derivation is also necessary. In addition to locative alternation verbs, a derivation from a locative variant would permit a class of verbs with only a locative version as in (6), but not the class of verbs having only the with version, as in (7).

- (6) a. Irv poured water into the glass.
b. *Irv poured the glass with water.

- (7) a. *John filled water into the glass.
b. John filled the glass with water.

Accordingly, there must be a derivation from the with variant as well. But Rappaport & Levin say nothing about this derivation. Even if they tried to find an appropriate one, it would be quite difficult to do so in their framework. A conceivable solution is to reverse the means relation, as Inagaki (1989) does. To accommodate a derivation from the

with variant, Inagaki (1989) proposes the following representations for the two variants of stuff.

- (8) a. STUFF: [x cause[y to come to be STUFFED with z]]
b. STUFF:
[[x cause [z to come to be at y]/STUFF] IN ORDER
THAT [x cause [y to come to be STUFFED with z]]]
(Inagaki 1989:222)

(8b) is to be read as: A change of location is brought about in order for a change of state to take place. For instance, stuffing feathers into the pillow is brought about in order for stuffing the pillow with feathers to obtain.

This analysis does not work, however. Even apart from its clumsiness, this paraphrase fails to convey the correct meaning. Stuffing feathers into the pillow is not necessarily done for the purpose of stuffing the pillow. Moreover, IN ORDER THAT entails that stuffing the pillow is not actually realized. Thus appeal to a purpose relation is unsatisfactory in these respects, and it seems quite difficult to come up with an appropriate extension relation that forms a locative variant from a with variant.

Second, the means extension analysis cannot be easily extended to other complement alternations. As is well-known, verbs other than locative alternation verbs also exhibit two variants.

verbs of inscribing

- (9) a. The jeweler inscribed a motto on the ring.
b. The jeweler inscribed the ring with a motto.

verbs of presenting

- (10) a. The judge presented a prize to the winner.
b. The judge presented the winner with a prize.

verbs of forceful contact

- (11) a. Kevin hit the stick against the wall.

b. Kevin hit the wall with the stick.

(Rappaport and Levin 1988:28-29)

The parallelism between complement and locative alternations is undoubtedly clear. But the means extension analysis creates bizarre readings for the with variants: Inscribing the ring with a motto is brought about by means of inscribing a motto on the ring; presenting the winner with a prize is brought about by means of presenting a prize to the winner; hitting the wall with the stick is brought about by means of hitting the stick against the wall. The means extension analysis as it stands is hardly convincing here.²

2.1.2. Pinker (1989)

Pinker (1989), essentially following the analysis of Rappaport & Levin (1988), argues that the locative alternation is effected by a lexical rule that operates on a semantic structure:

it is a rule that takes a verb containing in its semantic structure the core "X causes Y to move into/onto Z," and converts it into a new verb whose semantic structure contains the core "X causes Z to change state by means of moving Y into/onto it." (Pinker 1989:79)

The semantic structures are as shown below:

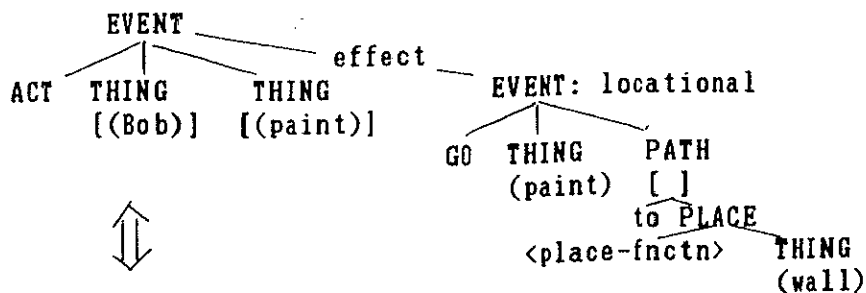

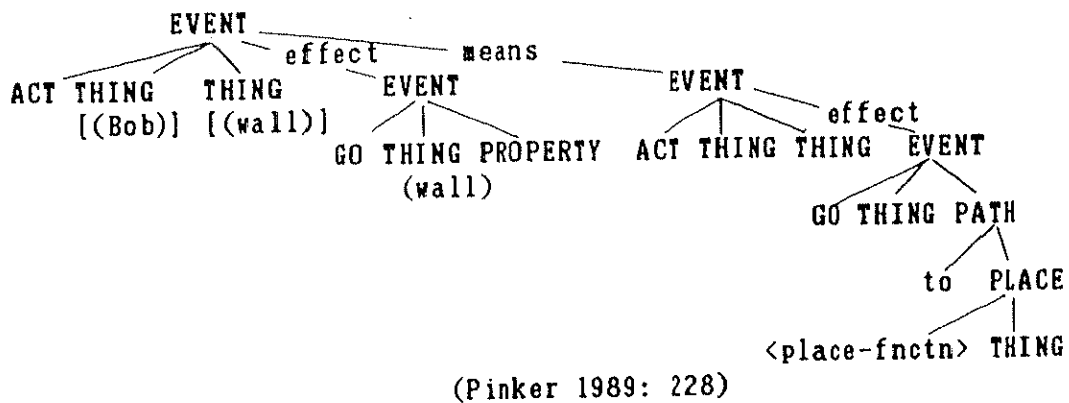

The relevant parts are shown as in (12). The whole EVENT structure for the locative variant (12a) is embedded in the means clause in (12b).

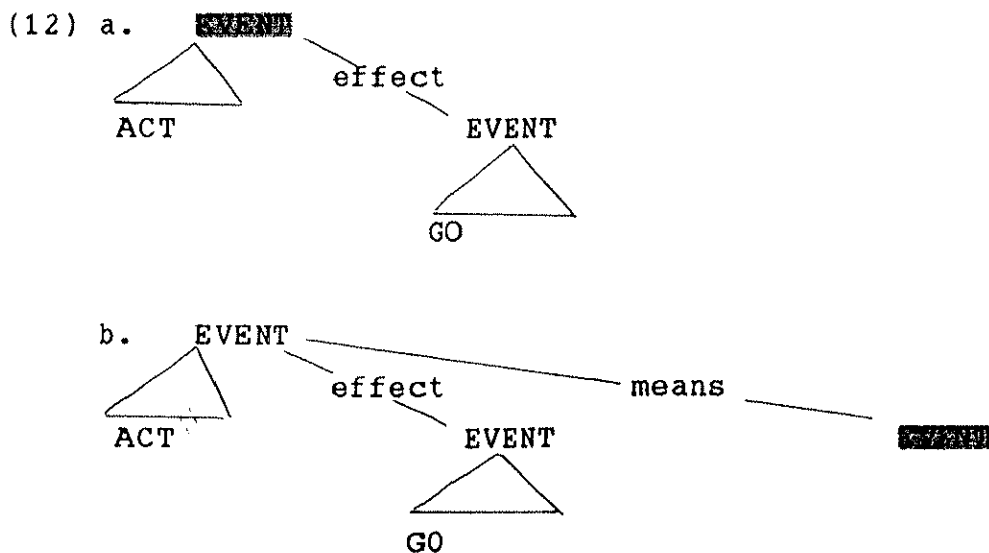

The two semantic structures are linked by a bidirectional arrow, because Pinker assumes that the derivation proceeds in either direction: from the locative variant to the with variant, or from the with variant to the locative variant. Directionality of the derivation is determined by the possibility of the direct argument standing as sole complement. If the theme NP, but not the goal NP, stands alone, then the derivation is from the locative variant to the with variant as in (13). If the goal NP, but not the theme NP, stands alone, then the derivation is from the with

variant to the locative variant as in (14). When either argument can stand as sole complement as in (15), the derivation can go in either direction.

- (13) a. He piled the books.
b. *He piled the shelf.
- (14) a. *He stuffed the breadcrumbs.
b. He stuffed the turkey.
- (15) a. He loaded the gun.
b. He loaded the bullets. (Pinker 1989:125)

Pinker's analysis differs from that of Rappaport & Levin in accommodating the derivation that goes from the with variant as well. But the very mechanism that Pinker introduces so as to guarantee the bidirectionality of derivation is problematic. First, it is rather doubtful whether the possibility of standing as sole complement truly serves as a diagnostic for the derivational base. As Pinker himself points out, some verbs allow neither the theme nor the goal argument to stand alone as in (16), and some verbs allow either argument to stand alone as in (17).

- (16) a. John heaped books on the shelf.
b. John heaped the shelf with books.
c.*?John heaped the books.
d. *John heaped the shelf.
- (17) a. John packed books into the box.
b. John packed the box with books.
c. John packed the books.
d. John packed the box. (Pinker 1989:38-39)

Thus the possibility of sole complement does not always serve as a diagnostic.

Moreover, the sole complement analysis seems hardly relevant to an account of locative alternation. It is true

that sole complement plays a significant role in a number of linguistic phenomena, such as adjectival passives, -able adjectives, middles, process -ing nominals, and verbal compounds (Itoh 1981, Levin & Rappaport 1986, Endo 1986, Iwata et al. 1987, Carrier & Randall 1992). These phenomena form a natural class, in that they all involve a category change or suppression of an external argument of the base verb. But the locative alternation involves neither; It is simply a matter of multiple subcategorization frames and is quite different in character from the above class.

The second problem concerns the plausibility of "extension". For clarity, I repeat (12) as (18).

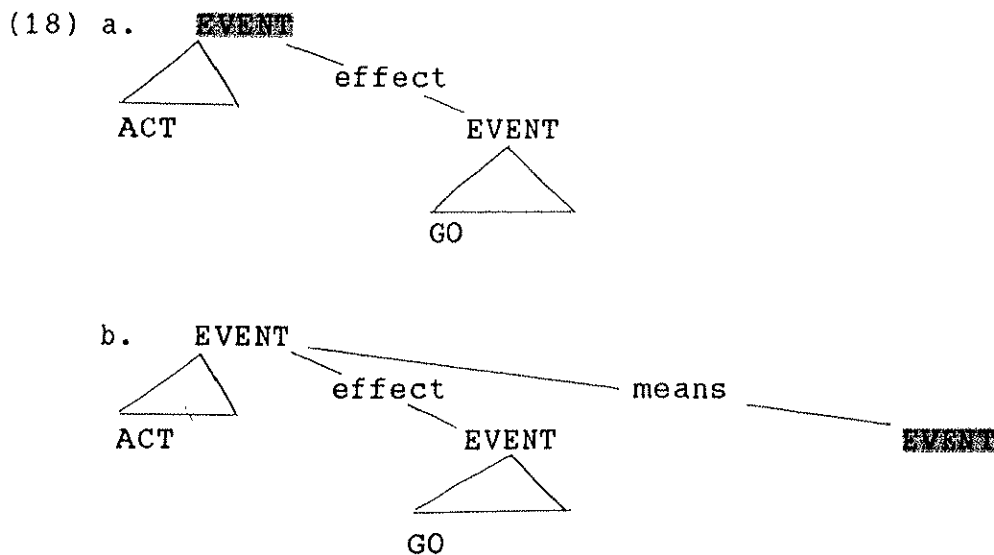

Pinker maintains that there are both a lexical rule that changes (18a) into (18b) and one that turns (18b) into (18a). While the former amounts to lexical subordination, the latter should be an "inverse of subordination." This means that verbs like stuff originally have the semantic structure of (18b), and that the putative lexical rule deletes the main clause, thereby promoting the erstwhile subordinate clause into the main clause. This derivation is too powerful and peculiar, and finds no analogue in other linguistic phenomena.

Finally, Pinker treats locative alternation as a special relationship between two variants. But the alternation is not restricted to the two alternants. Wrap allows three variants.

- (19) a. She wrapped the baby in a towel.
b. She wrapped the baby with a towel.
c. She wrapped a towel around the baby.

(Nakau 1986:624)

Pinker's analysis has difficulty in handling (19).

2.2. Analysis

2.2.1. Lexical Meaning and Phrasal Meaning

Both Rappaport & Levin (1988) and Pinker (1989) attempt to derive the semantic structure of one variant from that of the other, and both have difficulty with the derivation starting from the with variant. Both analyses hold the implicit assumption that semantic structure can, and should, fully account for the locative alternation. Yet nothing guarantees that every aspect of meaning can be fully represented in semantic structure.

2.2.1.1. Load

Fillmore (1971) says that certain instances of verbal polysemy seem to have developed in the following way:

Where one kind of activity is a possible way of carrying out another kind of activity, the verb which identifies the former activity has superimposed onto it certain syntactic and semantic properties of the verb which identifies the second or completing activity.³

(Fillmore 1971:385)

He claims that locative alternation is an instance of this superimposition.

The verb load, let us say, means to transfer objects onto or into a container of some sort. The activity of loading can lead to the filling of that container, and so the verb load has taken on the additional syntactic and semantic functions of fill.

- (20) a. He loaded bricks onto the truck.
b. He loaded the truck with bricks.
c. He filled the truck with bricks.

(ibid:386)

This indicates that the verb load has a meaning component that is very similar to fill, and that this similarity leads load to acquire a syntactic frame of fill. Building upon Fillmore's insight, then, the locative alternation can be described as follows:

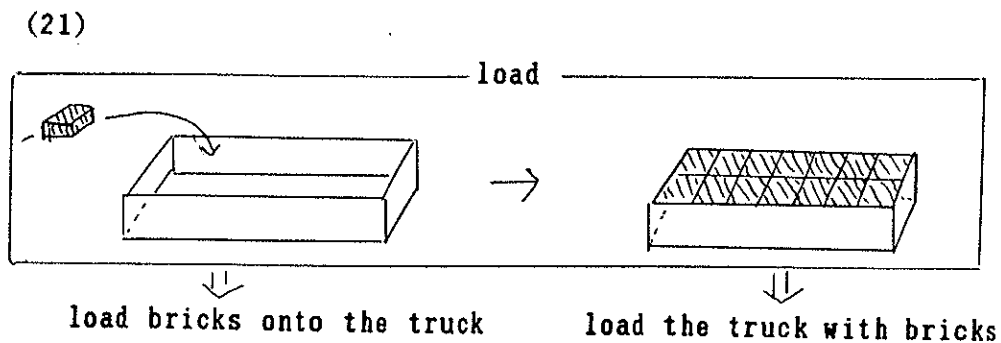

(21) reveals a crucial distinction between loading and loading bricks onto the truck. The meaning of loading is all that is enclosed in (21). That is to say, the verb load means to transfer objects onto a container and to fill that container. By contrast, loading bricks onto the truck denotes that part of the meaning of load which corresponds to transferring bricks onto the truck.

The denotation of a lexical head (Lexical meaning or L-meaning) is distinguished from that of a phrasal constituent (Phrasal meaning or P-meaning). An L-meaning pertains to a lexical verb per se, and is wider and more general than a P-meaning, which is associated with a particular syntactic frame (e.g. V NP onto NP, V NP with NP). In other words, when a lexical verb is combined with a syntactic frame, the L-meaning narrows down to the P-meaning associated with that frame. The locative alternation arises when the L-meaning is general enough to accommodate more than one P-meaning.

The L-meaning/P-meaning distinction reveals a serious flaw in the previous analyses reviewed in the last section. Rappaport & Levin (1988) and Pinker (1989) both derive loading the truck with hay from loading hay onto the truck, not from loading. That is to say, they attempt to derive one P-meaning from another, although what is actually going on is that a single L-meaning gives rise to two P-meanings, an entirely different matter.

Interestingly enough, Pinker says much the same:

Basically, it is a gestalt shift: one can interpret loading as moving a theme (e.g., hay) to a location (e.g., a wagon), but one can also interpret the same act in terms of changing the state of a theme (the wagon), in this case from empty to full, by means of moving something (the hay) into it. (Pinker 1989:79)

A gestalt shift means that objectively the same scene is open to two different interpretations.* If we substitute an L-meaning for the scene and P-meanings for two interpretations, then the above remarks make perfect sense; in the passage '... one can interpret loading as ...', Pinker speaks of loading, not of loading hay onto the wagon. Also, in the passage '... one can also interpret the same act ...', 'the same act' refers to the act of loading, not of loading hay

onto the wagon. Thus the L-meaning/P-meaning distinction is recognized, albeit implicitly. Consider further the following:

The constraints or criteria governing the locative alternation stem, to a first approximation, from the ability of a predicate to support this gestalt shift.

(Pinker 1989:79)

Here '... the ability of a predicate to support this gestalt shift' is another way of saying that the predicate has a meaning general enough to be interpreted in two ways.

Pinker's recognition of the locative alternation as a gestalt shift is consonant with my claim, but its formalization as a lexical rule creates problems revealed in his analysis of spray.

2.2.1.2. Spray

Pinker describes his conception of the locative alternation of (22) as (23).

- (22) a. Bob sprayed paint onto the wall.
 b. Bob sprayed the wall with paint.

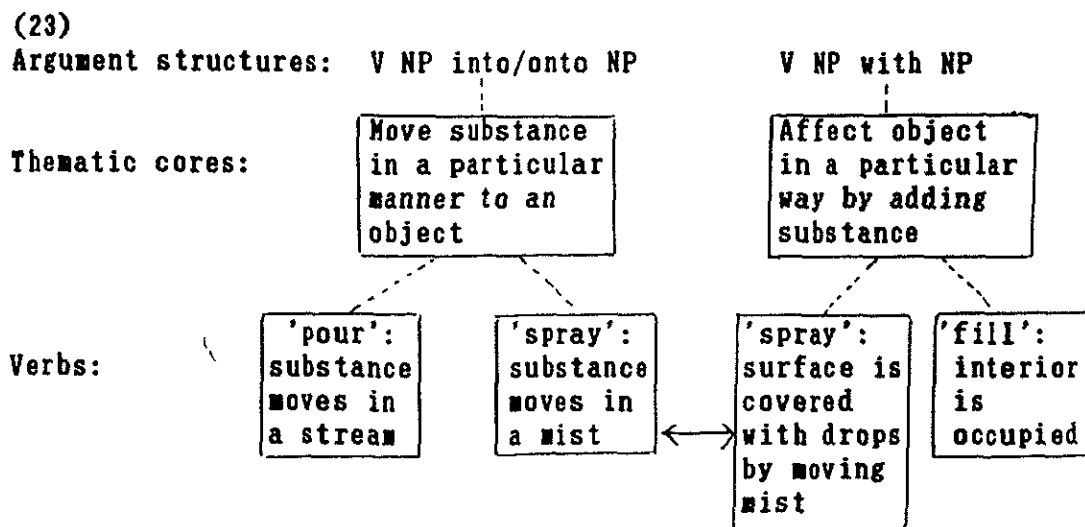

Lexical
rule
(Pinker 1989:80)

The term "argument structure" refers to a verb's syntactic frame. Each argument structure has one or more thematic cores: a schematization of a type of event or relationship that constitutes the core of the meaning of a class of possible verbs. Verbs like spray and pour contain the thematic core "X causes Y to move into/onto Z," with the argument structure V NP into/onto NP. A lexical rule converts the semantic structure into "X causes Z to change state by means of moving Y onto Z." The resulting verb is subsequently linked to the argument structure V NP with NP, sharing a class with fill.

Now let us consider (22) from our point of view.

(24)

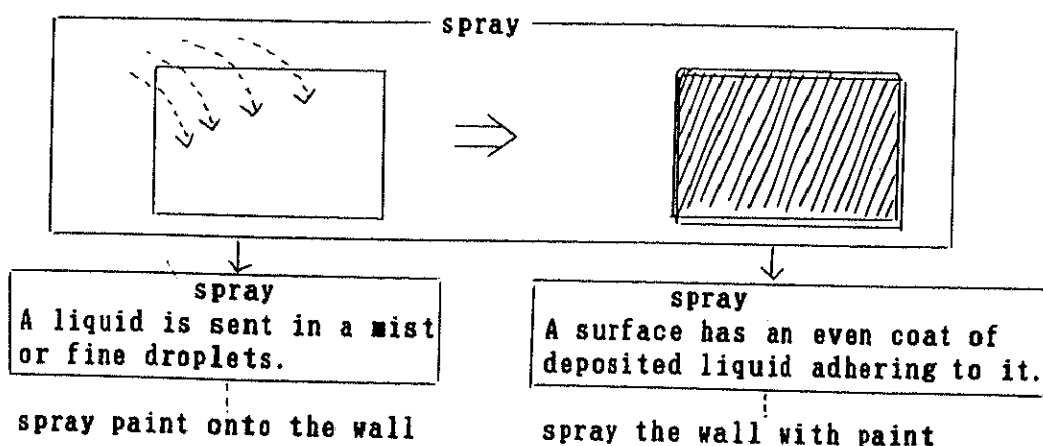

The L-meaning of spray is to send a liquid in a mist or fine droplets, and, as a result of this movement, a surface to which it moves has an even coat of deposited liquid adhering to it. If we focus upon the activity of sending, thereby choosing to encode that part of meaning, then spray appears in the frame V NP onto NP. On the other hand, when the completing activity is focused upon, spray ends up in the frame V NP with NP.

(23) as it stands is different from (24), but the basic

idea underlying the former is compatible with the latter. It is possible to integrate (23) and (24) into a coherent whole:

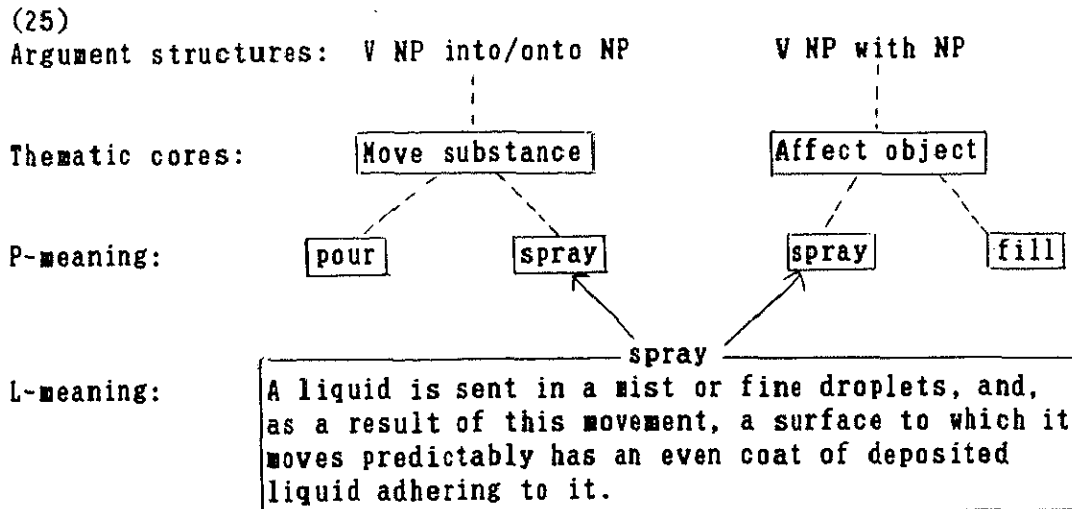

Comparison of (23) and (25) reveals the flaw in Pinker's formalization. Pinker is right in recognizing the locative alternation arises from the interaction of the verb's semantics with the syntactic frame. But confusing L-meaning with P-meaning leads to a lexical rule relating the two semantic structures.⁵

2.2.2. Dative Alternation and Construction Grammar

The idea that a single L-meaning gives rise to two P-meanings is not new, although not phrased exactly this way in the literature. Essentially the same idea has been put forth by Goldberg (1992) and Langacker (1986).

2.2.2.1. Goldberg (1992)

Gropen et al. (1989) analyze dative alternation in terms of a semantic operation on lexical structure, parallel to Pinker's (1989) analysis of locative alternation: A lexical rule takes as input a verb with the semantics X causes Y to go to Z (the prepositional expression) and produces the semantic structure X causes Z to have Y (the dative expression).

Goldberg (1992) rejects Gropen et al's analysis for three reasons. First, there appears to be little empirical evidence to show that the prepositional expression is more basic than the dative expression. Second, many verbs participating in dative alternation do not mean "X causes Y to go to Z" (e.g. bake, make, promise, permit, deny). Third, many verbs do not come to mean "cause to have" (e.g. bake Sally a cake, draw Sally a picture).

The alternative that Goldberg proposes is "to attribute the semantics directly to the construction instead of to the specific verbs involved," where a construction is a form-meaning correspondence that exists independent of individual verbs. That is, the semantics of "X causes Y to have Z" is attributed directly to the skeletal syntax [Subj [Verb Obj Obj2]]. On this account, Goldberg argues, "the dative alternation itself can be seen to be a result of semantic overlap between the two constructions". Thus we have only one verb send in (26).

- (26) a. I sent a package to him.
b. I sent him a package.

Goldberg goes on to say as follows:

The sending scene referred to in both sentences is compatible with a description in terms of I caused a package to go to him or I caused him to receive a package, with little if any noticeable change in meaning so either construction is licensed. (Goldberg 1992:46)

Clearly, Goldberg's account in terms of construction is in the same spirit of my analysis of the locative alternation.⁶

2.2.2.2. Langacker (1986)

Langacker (1986) argues that neither of the sentences in (27) is derived from the other.

- (27) a. Bill sent a walrus to Joyce.
 b. Bill sent Joyce a walrus.

Instead, the two sentences represent "alternate construals of the profiled event." That is, they employ subtly different images to structure the same conceived situation. The essentials of his analysis are sketched in (28), where the small circles represent Bill, Joyce, and the walrus; the large circles stand for the regions over which Bill and Joyce exercise dominion; and boldface indicates a certain degree of relative prominence. In (27a) the path followed by the walrus is prominent, whereas in (27b) the possessive relationship between Joyce and the walrus is given more prominence.

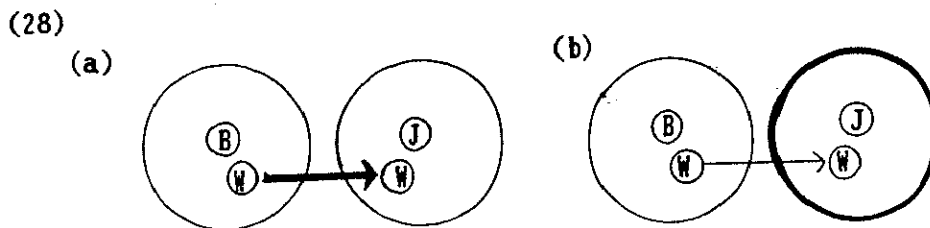

Langacker's analysis amounts to the claim that the dative alternation results from a gestalt shift.

2.2.3. An Overall Picture

Now an overall picture emerges as in (29).

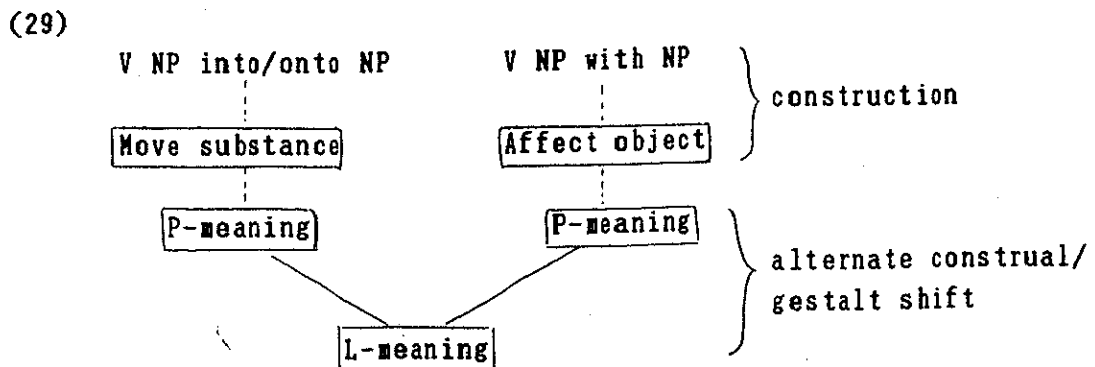

Syntactic frames are associated with identifiable meanings, and this pairing of form and meaning amounts to "construction" in the sense of Goldberg (1992). A verb can appear in a syntactic frame when its L-meaning is compatible with the semantics of a construction. The verb spray, whose L-meaning includes both manner of motion and effect, is thus capable of taking both into/onto and with forms. Which syntactic frame is chosen is determined by which aspect of the L-meaning is given more prominence, this process being a gestalt shift or "alternate construal of the same situation" in the sense of Langacker (1986).

On this account, the locative alternation verbs are no different from non-alternating verbs in their basic form-meaning correspondences. As pointed out in 2.1.1., there are both a class of verbs that occur only as a locative variant (e.g. pour) and a class of verbs that occur only as a with variant (e.g. fill). The two classes are distinguished by the difference in their L-meanings. The L-meaning of pour, which specifies pure manner of motion, only gives rise to a P-meaning associated with the into/onto form (locative variant). By contrast, the L-meaning of fill, which specifies pure effect, gives rise to a P-meaning associated with the with form (with variant) alone.

Crucially, this account has the advantage of circumventing the problem posed by one of the putative derivations. As seen in Section 2.1., neither Rappaport & Levin (1988) nor Pinker (1989) can offer a plausible account of the derivation from the with variant. But since locative alternation is not a matter of deriving one variant from the other, no lexical rules are needed in my account.

2.3. Application

As pointed out in Section 2.1., the means extension

analysis of Rappaport & Levin (1988) and Pinker (1989) is not plausible for verbs like hit. Nor can it straightforwardly account for verbs like wrap involving three alternants. My account can systematically handle these problematic cases as well.

2.3.1. Hit

Verbs of physical contact like hit alternate as in (30), like locative alternation verbs. Pinker (1989:105) points out that this alternation is contingent upon the verb meaning.

- (30) a. I hit the bat against the wall.
[cf. I hit the wall with the bat]
She bumped the glass against the table.
Bill slapped the towel against the sink.
- b. *I cut the knife against the bread.
[cf. I cut the bread with the knife]
*He split the ax against the log.
*Phil shattered the hammer against the glass.
*I broke a spoon against the egg.
*I touched my hand against the cat.
*I kissed my lips against hers.

Pinker observes that verbs of motion followed by contact can alternate, but not verbs of motion followed by contact and a specific effect (a cut, a break, a split) or verbs of contact without motion (touch, kiss).

This suggests that two constructions are at work here: the "change of location" sense in the against form; the "affect" sense in the with form. Verbs of hitting, which specify both motion and contact in their L-meanings, can fit into the semantics of either construction. Consequently they can occur in either syntactic frame. By contrast, verbs of breaking specify in their L-meanings a specific effect, as well as motion and contact, thus rendering the "affect" sense

more salient. Consequently, they are compatible only with the semantics of "affect". Verbs of touching simply lack the meaning component of change of location, so that they fit into only the semantics of "affect", too.

This supposition is confirmed by Dowty, who contrasts the classes of verbs that take only the with form and those that take only the against form (1991:596).

- (31) a. swat the boy with a stick
 b. *swat the stick at/against the boy
 Likewise: smack, wallop, swat, clobber, smite, etc.
- (32) a. *dash the wall with the water
 b. dash the water against the wall
 Likewise: throw, slam, bat, lob, loft, bounce, etc.

He further observes that verbs in (31) imply a pain-inflicting or punishing action, but those in (32) are used only when the change of position of the ball or projectile is important, not any effect of the action upon the location.

Thus the alternation hit enters into is described as follows:

(33)

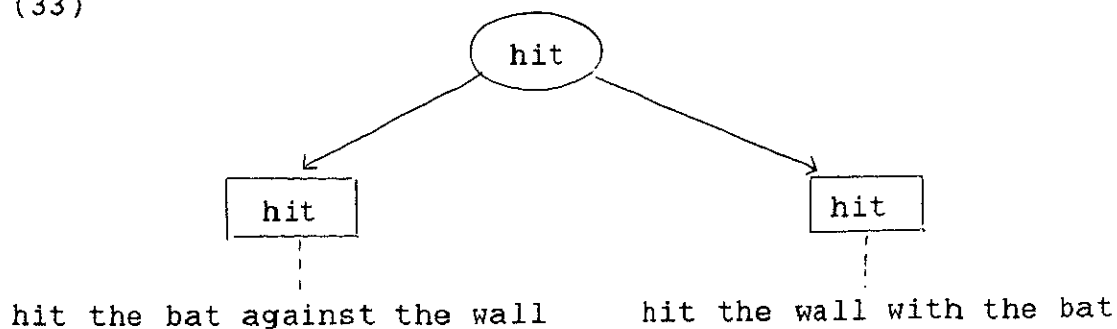

2.3.2. Wrap

The verb wrap has three variants as in (34).

- (34) a. She wrapped the baby in a towel.
 b. She wrapped the baby with a towel.

c. She wrapped a towel around the baby.

(Nakau 1986:624)

My account for the locative alternation is consistent throughout: The L-meaning of wrap is compatible with the semantics of each of the three constructions underlying their respective forms. The in form is found with verbs like plant or sow.

(35) a. The workers planted the trees in the garden.

b. The workers planted the garden with (*the) trees.

(Fraser 1971:605)

The around form is found with the following class of verbs.

(36) a. He coiled the chain around the pole.

b. *He coiled the pole with the chain.

coil, spin, twirl, twist, whirl, wind

(Pinker 1989:126)

And, of course, the with form is typically employed with verbs like cover. Thus the alternation is described as follows:⁷

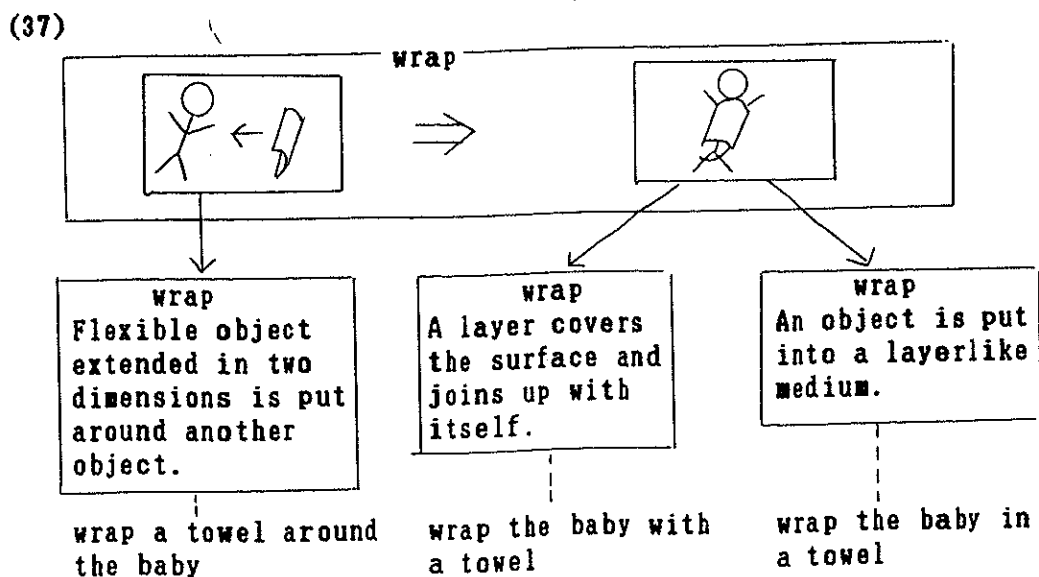

The L-meaning of wrap is to fold a flexible object around another object, with the result that the flexible object conforms to part of the shape of the enfolded object along two or more orthogonal dimensions. When prominence is given to that part of meaning corresponding to folding an object around another object, wrap takes the around form. If, on the other hand, the change of state is focused upon, two possibilities emerge. It is possible to regard the baby as being covered with a towel or as being put into a towel. Accordingly, wrap can take either the with or in form. The idea is summarized in (38).

(38)

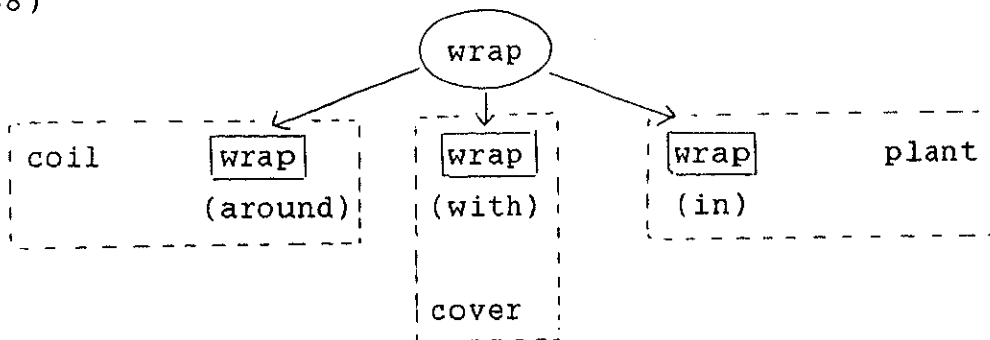

2.4. Means Extension Once Again

While the means extension analysis of Rappaport & Levin (1988) and Pinker (1989) is mistaken, it is nevertheless plausible at first sight. What makes the means extension analysis look plausible? and what led both Rappaport & Levin and Pinker to adopt the means extension analysis?

2.4.1. Why Means Extension?

In the means extension analysis, the with variant subordinates the locative variant. Rappaport & Levin (1988:26) base this complex structure on an entailment relation: Henry loaded the wagon with hay entails Henry loaded hay onto the wagon, but not vice versa.

While the means extension analysis is one way to capture the entailment relation, it is not the only one. In my

account, the two variants are obtained by attaching prominence to different components of the same L-meaning. What's crucial is that events have distinct stages, which are both temporally and causally ordered. Obtaining the two P-meanings from the L-meaning of load amounts to partitioning the activity of loading into two components in accord with this order. Thus the change of location, i.e. transferring objects onto a container, precedes the change of state, i.e. the container being full, both in a temporal order and a causal chain: The time at which the change of location takes place is necessarily prior to the time at which the change of state takes place. Also, the change of state cannot take place without the change of location. The former presupposes the latter. This precedence relation, holding between a change of location and a change of state, is the origin of the entailment relation which Rappaport & Levin note.

Its similarity to this precedence relation makes the means extension analysis look plausible. A means relation connects two distinct events, one of which precedes the other both temporally and causally. With locative alternation verbs, the things undergoing a change of location being typically mass or multiplex entities, the activities denoted by the verbs tend to have some temporal duration: One usually does not load the wagon with hay by transferring a load of hay onto the wagon just once. Rather, repeated transferring activities are usually involved. Because of this temporal interval, the activity of transferring hay onto a wagon and that of filling the wagon are apparently temporally distinct from each other. By contrast, the activities of inscribing, presenting, and hitting do not take much time. For instance, hitting being punctual, it is rather difficult to regard hitting a stick against the wall as being temporally distinct from hitting the wall with a stick. This is the reason why to say that loading the wagon with hay is brought about by means of loading hay onto the wagon is more tolerable than to say

that hitting the wall with a stick is brought about by means of hitting a stick against the wall.

2.4.2. Why Derive One from the Other?

Why does Pinker formalize the locative alternation gestalt shift as a lexical derivation? First, Pinker assumes that semantic structures are the only syntactically relevant aspects of meaning; thus, he ignores Lexical meanings, which fall outside the realm of semantic structures. I argue, however, that semantic structures can deal with P-meanings but not with L-meanings. If anything, pictorial representations are more suitable for L-meanings of locative alternation verbs.⁸ Second, I argue that lexical items are natural sense categories and like other such categories they are frequently but mistakenly represented metonymically by members or subcategories, particularly by prototypical members. (Lakoff 1987:84, 418) Since P-meanings stand in a member-category relationship to their respective L-meanings, it is natural to construe loading hay onto the wagon, a member of the category load, as the category itself, especially since the verb load almost never appears without phrasal complements.

Pinker does not question the assumption that a relationship between two variants implies that one is derived from the other. This assumption in turn finds its roots in the classical notion of categorization that category members all share a "core" of properties:

CLASSICAL CATEGORIZATION: All the entities that have a given property or collection of properties in common form a category.⁹ (Lakoff 1987:161)

If one of the category members is taken as the core meaning itself, the only relation that can hold between that variant and all others is a derivational one. The underlying logic is

as follows: There are two variants of load. The only way to relate them is to derive one from the other. Therefore, there must be lexical rules that do so. Yet as we have seen, relationships between variants need not depend on one's derivation from another; instead, they may all derive from a common base.

2.5. Expect

Distinguishing L-meaning from P-meaning and subjecting the former to 'construction' is essential in accounting for syntax-semantics correspondences in general. While mainly concerned with spatial verbs, my account of form-meaning correspondences seems to extend to verbs of non-spatial, abstract meanings.

Take expect as a good illustration. Bresnan (1979) points out that the following three sentences have different underlying structures, although they share the V NP to VP sequence in surface form.

- (39) a. I wanted him to be better than he was.
 b. I believed him to be better than he was.
 c. I challenged him to be better than he was.

(Bresnan 1979:150)

A number of syntactic differences suggest that challenge has a V NP S configuration, whereas want and believe have a V S configuration.

(40)

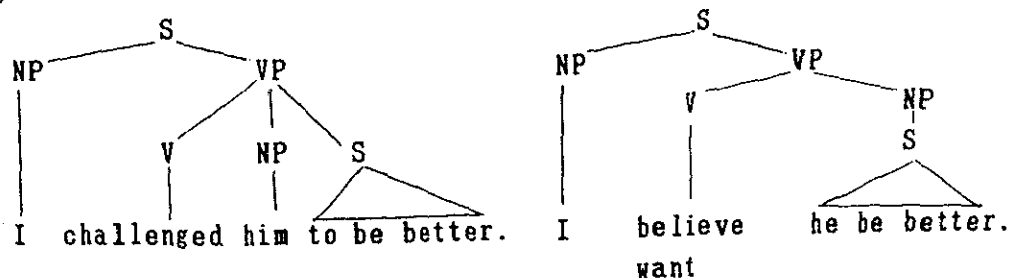

Bresnan argues that want- and believe-type verbs are distinguished from each other by the following four parameters:

(41)	<u>want</u> -type	<u>believe</u> -type
I) takes <u>for</u> -complement	+	-
II) permits passivized subject of infinitive	-	+
III) permits Equi	+	-
IV) permits reflexive subject of infinitive	-	+

What is striking is that the verb expect has properties of want, believe, and challenge. Thus, in (42), expect behaves like want, allowing a for-complement and permitting Equi.

- (42) a. I don't expect at all for you to believe me.
b. I don't expect to be believed.

In (43), expect behaves like challenge: It has a compulsive sense and requires an animate object, and its direct object can be passivized, as with challenge.

- (43) a. As long as I'm boss, I will expect everybody to have a share in the office work.
b. As long as I'm boss, everybody will be expected to have a share in the office work.

In (44), expect has a predictive sense, and can be passivized as can believe.

- (44) a. I expect her friend to be quite tall.
b. Her friend is expected to be quite tall.

Thus, the behavior of expect falls into three patterns:

the "compulsive" expect takes a direct object NP followed by an S like challenge; the "intentional" expect takes a for-complement like want; the "predictive" expect has the syntactic properties of epistemic verbs like believe (Bresnan 1979:163-65).

The existence of three types of expect is not surprising from our point of view. There are three constructions that link want-, believe-, and challenge-type verbs with their respective syntactic structures. The L-meaning of expect fits into the semantics of any of the three constructions, yielding the three P-meanings. Thus, the "compulsive" expect means 'to have a desire for somebody to do something and try to cause him to do it,' similar to challenge. The "intentional" expect means 'to have a desire for something to happen and try to cause it to happen,' similar to want. The "predictive" expect means 'to have a desire that something be the case,' similar to believe.

(45)

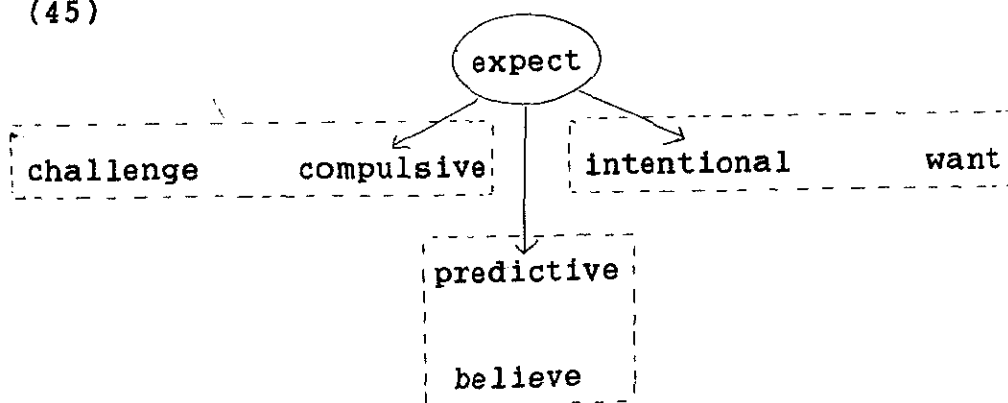

On the other hand, the means extension analysis or some version of it has little to say about the three types of expect. It makes little sense to claim that one of the three is basic, from which the rest are derived by a means extension.

2.6. Conclusion

It has been shown that an adequate analysis of locative alternation has to recognize (a) the L-meaning/P-meaning distinction and (b) the form-meaning correspondences which exist independent of particular lexical items. Locative alternation arises from the interaction of L-meanings with the form-meaning correspondence mechanism, and thus locative alternation verbs are no different from other verbs in this respect.

This suggests that the form-meaning correspondence model arrived at in this chapter can be extended to other linguistic phenomena, a possibility to be explored in the next chapter.

Notes to Chapter 2

1. In the literature a holistic interpretation has often been tied up with the with variant (Fillmore 1968, Anderson 1971). In fact, Rappaport and Levin (1988) cite the holistic interpretation as one of the issues which an adequate analysis must handle. However, it is mistaken to attribute a holistic reading directly to the with variant (See Jeffries & Willis (1984) and Jackendoff (1990:172) among others). Thus this issue will not be addressed in the present chapter.

2. Still another problem is that the putative paraphrase relations are unconstrained and quite arbitrary. Marantz (1992:187), in arguing against the lexical extension approach a la Levin & Rappaport, points out that the semantic structure proposed for the "extended" sense can be applied to almost any change-of-state verbs in English: "X hits Y" can be paraphrased as "X makes contact with Y by hitting"; "X walks" can be paraphrased as "X goes by walking"; and so on.

3. The same idea is put forth in Fillmore & Atkins (1992).

4. Recall celebrated examples of gestalt shift like "Rubin's vase" or "duck-rabbit". In all these cases, one and the same

environmental input may receive two different interpretations.

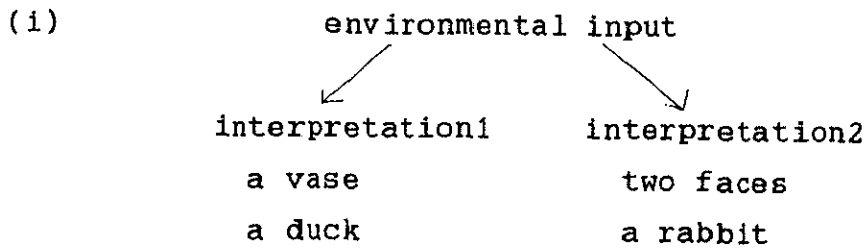

A gestalt shift does not in any way derive one of the interpretations from the other.

5. Some might argue that with some verbs, one of the variants seems more basic than the other. But this does not mean that the two variants must be derivationally related. It is conceivable that even when the L-meaning fits more than one thematic core, it fits one of them more comfortably. The seeming asymmetry is due to the shift from a more comfortable fit to a less comfortable fit when the L-meaning is assessed, and not to derivational directionality.

6. I will return to this issue in Chapter 3.

7. This account is compatible with Nakau's (1986) observation that with the with and around forms it is the towel that was moved, while with the in form it is the baby.

8. Hale and Keyser (1987) allude to a level prior to semantic structure, which they call the Primitive Conceptual Structure (PCS). The PCS is claimed to be the most elemental representation of lexical conceptual structure, possibly "pre-linguistic." Their idea is described as in (i).

(i)

PCS of 'break':

[cause [separation in material integrity, of rigid or
taut entity]]



+event position, argument variable

LCS of 'break':

[x cause [y, rigid or taut entity, develop separation in
material integrity], (by ...)]

It might be argued that PCS can be the level for L-meanings. However, Hale & Keyser do not discuss the L-meaning/P-meaning distinction or a gestalt shift.

9. Actually, this is the first half of the original statement in Lakoff (1987), which continues as:

Such properties are necessary and sufficient to define the category. All categories are of this kind.

(Lakoff 1987:161)

Chapter 3
The Relevance of Constructions

3.0. Introduction

In the last chapter, I argued against the means extension approach and proposed an alternative account that can be summarized in Fig.1.

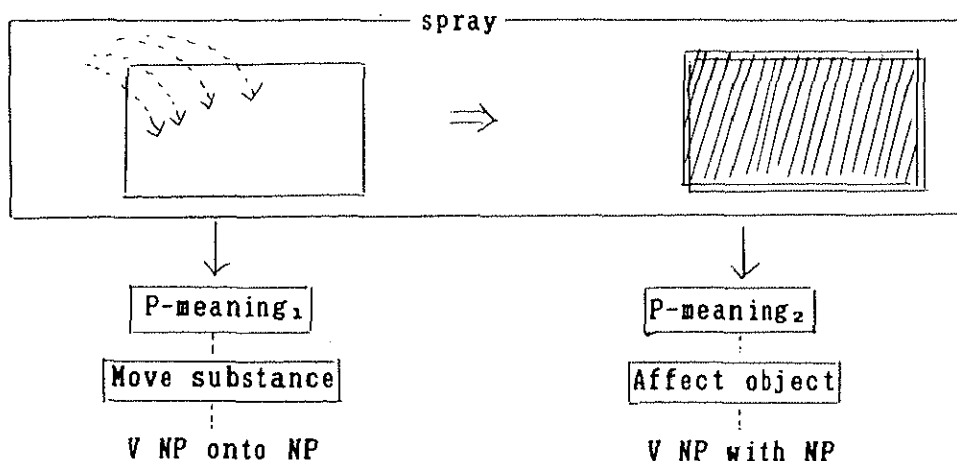

Fig. 1

The single L-meaning gives rise to two variants via form-meaning correlation. There is no need to posit lexical rules relating the two variants, since neither of the two variants is derived from the other at all.

I will compare this model with Goldberg's (1992a, 1992b) construction grammar approach, which similarly rejects lexical extension. In fact, the two analyses amount to essentially the same claim about the form-meaning correspondences. I will then show that the model extends to other phenomena, thereby strengthening my claim that there is no need to posit lexical rules relating the variants.

3.1. Construction Grammar

3.1.1. Goldberg (1992a, 1992b)

Goldberg argues that constructions are form-meaning correspondences which exist independently of particular verbs, carry meaning, and specify the syntactic structure of

certain linguistic expressions whose syntax and semantics are not predictable from the information encoded in individual lexical entries. The constructions which Goldberg proposes include the ditransitive (Joe gave him a present), the caused-motion (Sam sneezed the napkin off the table), the resultative (John hammered the metal flat), X's way (Tom belched his way out of the restaurant), and so on. In each construction, the constructional meaning is integrated with the verb meaning. For example, the ditransitive construction is represented as follows:

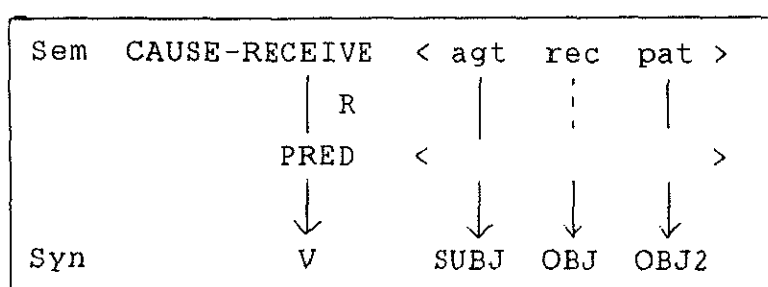

Fig.2 (Goldberg 1992b:46)

CAUSE-RECEIVE <agt pat rec> is the semantics associated directly with the construction, while PRED is a variable that is filled by a particular verb. The semantic roles associated with the construction (= argument roles) are fused with those associated with the verb (= participant roles). For instance, the verb hand is associated with three participants: hander, handee, handed. These three participant roles are put in a correspondence with the argument roles, resulting in the following composite fused structure:

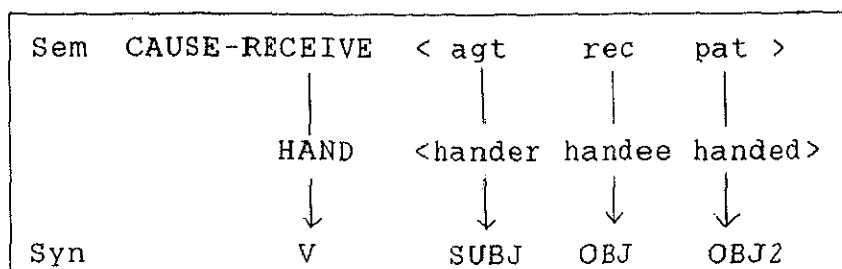

Fig.3 (Goldberg 1992b:47)

Although Fig.3 might seem different from Fig.1, they convey essentially the same idea, and it is possible to translate one representation into the other. Take the locative variant of load as an example. As seen in the last chapter, the verb load, when construed as a verb of putting, acquires the syntax of put. This is represented as in Fig.4.

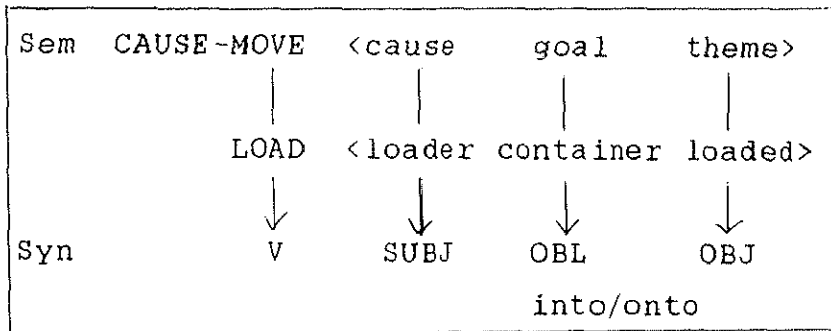

Fig.4

Fig.4 gives us a clear idea of the correspondences between the elements in Fig.3 and those in Fig.1: The constructional meaning corresponds to the thematic core; the verb meaning to the L-meaning; the syntactic level of grammatical functions to the syntactic frame.

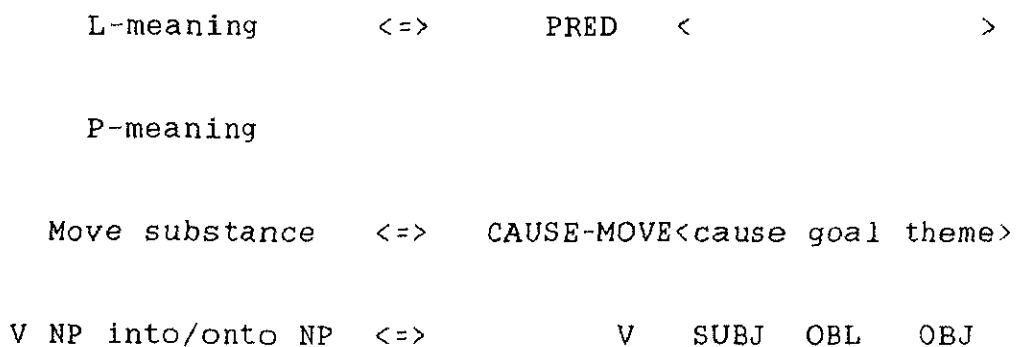

Fig.5

3.1.2. Fundamental assumptions

The parallelism between my analysis and that of Goldberg goes beyond the mere notational correspondences expressed in

Fig.5. In fact, the two analyses share a number of fundamental assumptions.

First, I agree with Goldberg that the verb meanings must be frame semantic meanings i.e. they must include reference to a background frame rich with world and cultural knowledge. Goldberg illustrates the necessity of rich frame semantic knowledge with examples of caused-motion construction.

- (1) a. Joe walked into the room with the help of a cane.
b. ?Joe marched into the room with the help of a cane.
c. ??Joe rolled into the room with the help of a cane.
d. *Joe careened into the room with the help of a
cane. (Goldberg 1992b:24)

In order to predict the distinction between (1a) and (1d), for instance, it is not enough to know that walk and careen are motion verbs with a manner component. Rather, reference to the particulars of manner is essential.

The same thing can be said of the L-meaning in my account. For instance, the L-meaning of spray specifies that a substance is moved in a mist in the direction of a particular object, resulting in the substance's being deposited on the object, while that of pour specifies merely that a substance is moved downward in a stream. Aspects of verb meaning like these tend to be neglected and relegated to "pragmatics", on the ground that only the skeletal meanings like X ACT or X CAUSE Y TO GO are grammatically relevant (Pinker 1989) and such world knowledge is grammatically irrelevant. However, it is precisely these aspects of verb meaning that explain why spray, but not pour, enters into locative alternation.

Thus all semantic knowledge associated with verbs must be recognized in order to represent their grammar. It is true that frame semantic knowledge is difficult to concisely paraphrase, let alone formally represent. But this difficulty should not be an excuse for neglecting significant portions

of verb meaning.

Second, I also agree with Goldberg that it is the constructional meaning, not the verb meaning, that determines the event type of the fused expression. Because a single clause can define only a single event type, the verb meaning cannot determine the event type. Consequently, the verb meaning is demoted from the main clause and comes to designate a particular salient aspect of the semantic frame determined by the construction. In many cases, the contribution of the verb meaning manifests itself as a means by which the action is performed. In this sense, there is some truth to the claim that "the MEANS relation licenses extended uses" (Rappaport and Levin 1988:30).

However, the means relation is only one of the several possibilities. Goldberg (1992b:59-60) observes that the event type designated by the verb must be related to the event type designated by the construction as: (a) a subtype, (b) a means, (c) a result, (d) a precondition, or (e) manner, means of identifying, intended result.

Moreover, some of the relations resist being formally represented as a subordinate function. For instance, when verbs of sound emission occur in the construction that designates motion as in (2), the sound is not in a means relation to the motion. Rather, the sound is a result of the motion and occurs simultaneously with the motion.

- (2) a. The wooden-legged man clumped into the room.
- b. The train screeched into the station.
- c. The fly buzzed out of the window.

(Goldberg 1992b:56)

It is quite hard, if not impossible, to come up with an appropriate subordinate function, parallel to the MEANS function, that correctly captures the meaning of (2).

Proponents of the lexical approach invariably resort to

lexical subordination, as if to suggest that the essence of "meaning extension" lies in embedding one representation in a subordinate clause of the other (Rappaport and Levin 1988, Levin and Rapoport 1988, Levin and Rappaport 1991, Pinker 1989, among others). Thus Levin and Rapoport (1988) attempt to reduce all their eight "lexical extensions" to a single scheme in (3):

- (3) LCS: manner/instr \rightarrow LCS: [result BY manner/instr]
(BY is used to represent 'by means of' or 'in the manner of') (Levin and Rapoport 1988:282)

But what is truly crucial is the main clause, not the subordinate clause, of semantic structure.

Finally, one important point apparently distinguishes between our accounts. Goldberg's construction grammar approach primarily aims to capture form-meaning correspondences that fall outside of the lexical entry. For instance, consider (4).

- (4) a. Sally baked her a cake.
b. He sneezed the napkin off the table.

In (4a), the sense of transfer and the syntactic frame NP V NP NP are not lexically specified by bake, but contributed by the ditransitive construction. Similarly, in (4b) it is the caused-motion construction, not the lexical entry of sneeze, that defines the sense of motion and the associated syntactic frame. Clearly, in these cases constructions provide syntactic and semantic properties that are not lexically encoded in the verb.

By contrast, my account of locative alternation is concerned with what has traditionally been called subcategorization frames and their semantics, i.e. syntactic and semantic information lexically encoded. Both change of

location and change of state are directly encoded in the L-meaning of verbs that enter into the alternation.

But this indicates just that the locative alternation is a limiting case where the verb meaning matches the constructional meaning. Constructions may play a role in determining lexical information as well as extralexical information. It seems plausible to suppose that any form-meaning correspondence may acquire the status of a construction, and Goldberg herself appears to allow for such a possibility in the following passage:

The give-class of verbs may be viewed in fact as motivating the existence of the construction. That is, language users may note a correlation between the syntactic form and the semantic interpretation associated with expressions involving these lexical items. Speakers are then able to abstract away from the particular lexical items, allowing the construction to achieve independent status. Once this occurs, the construction can be used to impose its meaning on other novel lexical items. (Goldberg 1992a:71, note 5)

It makes sense to claim that there are constructions which are motivated by pour or cover, and which allow semantically similar verbs to acquire multiple senses.¹

To recapitulate, my account and Goldberg's construction grammar approach are fundamentally the same: Versions of the construction grammar approach to be contrasted with the lexical approach.

3.2. Verbs of Removal

In this section, I apply my analysis to locative alternation which involves verbs of removal, like clear and wipe.

3.2.1. Levin and Rappaport (1991)

Levin and Rappaport (1991) propose a lexical extension approach to this alternation. There are three classes of verbs that can be used to express the notion of removal: remove-verbs, clear-verbs, and wipe-verbs. Remove-verbs appear with a syntactic frame whose direct object represents the locatum, or thing removed.

(5) Monica removed the groceries from the bag.

(6) *Monica removed the bag.

Clear- and wipe-verbs, however, alternate like spray/load verbs. Clear- and wipe-verbs may appear in a syntactic frame which represents the locatum as the direct object, and the location as a prepositional phrase: the locatum-as-object variant.

(7) a. Doug cleared dishes from the table.

b. Kay wiped the fingerprints from the counter.

Clear- and wipe-verbs also appear in the location-as-object variant.

(8) a. Doug cleared the table.

b. Kay wiped the counter.

Finally, clear-verbs can express the locatum in an of-phrase as in (9). But this is not the case with wipe, as shown in (9b).

(9) a. Doug cleared the table of dishes.

b. *Kay wiped the counter of fingerprints.

The set of contexts in which clear and wipe occur are summarized below.

- (10) a. Kay wiped the fingerprints from the counter.
b. Kay wiped the counter.
- (11) a. Doug cleared dishes from the table.
b. Doug cleared the table (of dishes).

Levin and Rappaport (1991) argue that although the three classes uniformly appear to denote an action that involves the removal of a substance from a location, they systematically differ in their basic meanings. The basic meaning of the clear-verbs includes a resultant state, but does not specify how the removal is effected. It is possible to clear an obstructed path in various ways: by raking, sweeping, or shovelling it. As long as the raking, sweeping, or shovelling results in the path being unobstructed, the action can be described as clearing the path. The clear-verbs are basically change-of-state verbs.

In contrast, the basic meaning of the wipe-verbs specifies how the removal of a substance from a location is effected, but does not specify a resultant state. It is possible to wipe a blackboard without making it clean. The wipe-verbs are basically verbs of surface contact through motion, like rub, scrape, and scrub. The sense of removal is not a necessary component of the basic meaning, as evidenced by the fact that some of the wipe-verbs are used also as verbs of putting.

- (11) a. Kay wiped the polish onto the table.
b. Lynn scraped the leftovers into a bowl.

(Levin and Rappaport 1991:136)

Finally, the remove-verbs simply describe the removal of something from a place. They do not specify how the action is performed. Snow can be removed from a road in a variety of ways: by shovelling, raking, sweeping, etc. Nor do they

specify what effect the removal has on the location: Snow can be removed from a road without clearing the road.

Thus clear- and wipe-verbs are not basically verbs of removal. In their basic senses clear- and wipe-verbs appear in the location-as-object variant (NP V NP), but not in the locatum-as-object variant (NP V NP from NP) characteristic of verbs of removal. The locatum-as-object variants are lexically extended senses. Thus, wipe-verbs take on an extended sense of removal, meaning "to remove by means of surface contact through motion wipe." Wipe-verbs may also take on an extended sense of putting, meaning "to put by means of surface contact through motion wipe." Hence wipe-verbs can be used either as verbs of removal as in (5b) or as verbs of putting as in (12).

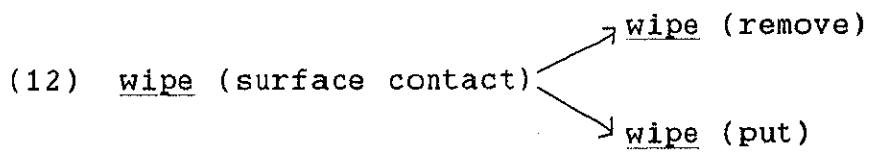

Locatum-as-object variants of clear-verbs also acquire an extended sense of removal, which Levin and Rappaport claim means "remove by means of change of state clear."

(13) clear (change of state) -> clear (remove)

In this way, the alternations exhibited by clear- and wipe-verbs are attributed to their multiple senses, which are related via a process of lexical extension.

3.2.2. Analysis

Levin and Rappaport thus argue that the location-as-object variant of verbs of removal is derived from the basic locatum-as-object variant. But notice the absurdity of the above characterization of removal clear as "to remove by

means of change-of-state clear". Doug cleared the dish from the table conveys that Doug removed the dish from the table, and as a result the table became clear, not that Doug first made the table clear, thereby removing the dish from it. In other words, the change of state expressed by clear cannot possibly be called a means to the act of removal.

This problem is inherent in the lexical extension approach, which is necessarily committed to an asymmetry between the two variants. Recall that the putative derivation sounds plausible only in the same direction as the temporal unfolding of the event (See 2.4.1). Thus with spray/load verbs, to say "a change of state is brought about by means of a change of location" sounds fine, because a means relation is compatible with the fact that a change of location precedes a change of state both temporally and causally. Similarly, to characterize removal wipe as "to remove by means of surface contact wipe" seems plausible just because surface contact precedes the removal of a substance from the surface. However, one cannot felicitously say that the act of removal is brought about by means of the resultant state (= being clear).

Such a problem does not arise in construction-based approach, which does not have to assume an inherent asymmetry between the variants, as seen in the last chapter. My construction-based account goes as follows. First, the L-meanings of the three classes are illustrated as below:

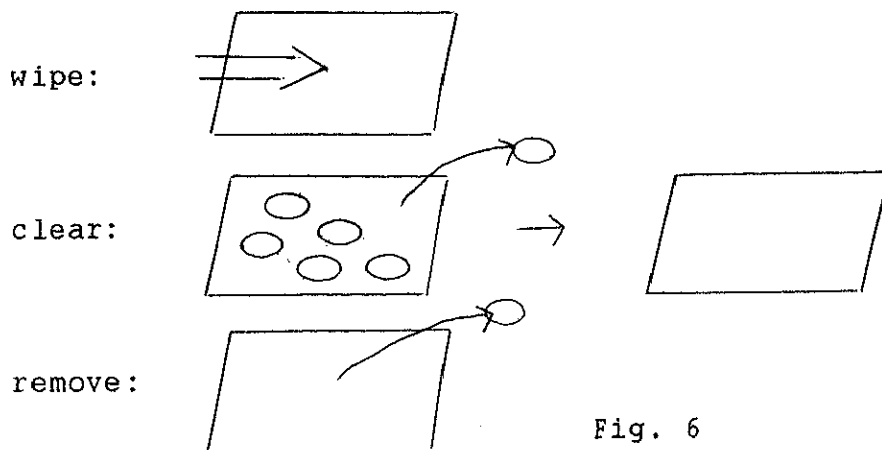

Fig. 6

The L-meaning of wipe specifies motion through surface contact, while that of clear codes a change of state (i.e. being clear) as a result of the action. The L-meaning of remove specifies just the removal of a substance from a location.

Next, there are three constructions i.e. patterns of form-meaning correspondence, which are probably motivated by clear (for (15a)), wipe (for (15b)), and remove (for (15c)), respectively.

(15) a. V NP
 |
 Cause to come to be in state

b. V NP
 |
 Move a substance against a surface

c. V NP from NP
 |
 Cause to go away from a location

The L-meanings interact with these constructions to yield the syntactic and semantic properties of the three classes of verbs in the following way. First, remove is a verb of removal pure and simple, so that its L-meaning fits into only the thematic core of "to cause to go away from a location".² The semantic structure thus obtained is linked to the syntactic frame V NP from NP.

(16) X remove Y from Z
 [CAUSE([X],[GO([Y],[FROM Z]])]]

Next, the L-meaning of clear is readily construed as

falling under the thematic core of "to cause to come to be in state", thereby yielding the following pair of a semantic structure and the syntactic frame.

- (17) X clear Y (of Z)
 [CAUSE([X],[INCH[NOT BE([Z],[ON Y]])]])]

But the L-meaning of clear does not exclude the construal as a verb of removal; Clear can be also construed as fitting into the thematic core of "to cause to go away from a location", and this construal allows clear to acquire the syntax and semantics of verbs of removal.

- (18) X clear Y from Z
 [CAUSE([X],[GO([Y],[FROM Z]])])]

The overall picture is (19):

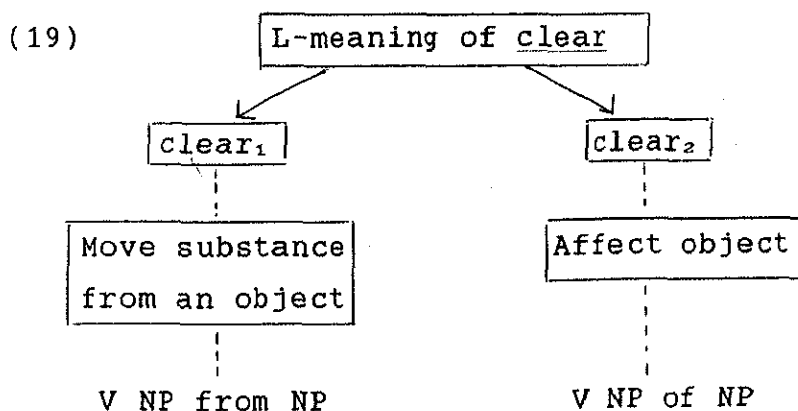

The alternation that clear exhibits comes from a gestalt shift, just like that of load: One can interpret the act of clearing in terms of changing the state of a location, but one can also interpret the same act as removing a theme from the location. There is no need to bother about the variants' derivation, because neither is derived from the other.

Finally, the L-meaning of wipe specifies only motion through surface contact, giving rise to the syntax and

semantics in (20).

(20) X wipe Y

[CAUSE([X],[GO_c([Z],[VIA_c[AT_c([Y])]])])]

The subscript c is employed to indicate 'contact', following Jackendoff (1990:110). The variable Z is contextually filled in.

Neither the sense of removing nor that of putting is directly encoded in the L-meaning of wipe, since it may express either sense:

(21) a. Kay wiped the fingerprints from the counter.

b. Kay wiped the polish onto the table.

This might appear to be problematic for my claim that the L-meaning of wipe does not encode the senses of putting or removing. Yet these two uses are to be different from ordinary cases of alternation. As Jackendoff (1990) points out, these uses are instances of spatial resultatives (caused-motion construction in Goldberg's terminology). Therefore, the senses of removing (21a) and putting (21b) are obtained by superimposing the semantics of respective constructions onto the L-meaning of wipe, like the resultative sense in (22).

(22) Kay wiped the counter clean.

(Levin and Rappaport 1991:144)

In (21a) and (21b) the L-meaning and the constructional meaning can be successfully integrated because they are in a causal relationship ((Causal Relation Hypothesis (Goldberg 1992b:55)): Wiping typically denotes actions that lead to removing an entity from a location, as well as actions resulting in putting an entity onto a location. Thus (21a)

and (21b) as well as (22) fall within the realm of constructions in the original sense of Goldberg (1992b).

The alternation that involves removing something from a location can be thus accounted for in my analysis. The alternations that the three verb classes exhibit are more complex than that of spray/load verbs, but the point is the same. The lexical extension analysis has to posit derivational relationships between the variants, but the putative derivation looks plausible in only one direction. By contrast, my account does not have to assume implausible derivations between the variants.

3.3. Denominal Verbs

Another phenomenon that seems to fall within the realm of constructions is a zero-derived denominal verb in English.

3.3.1. Locatum Verbs vs. Location Verbs

Clark and Clark (1979) classify denominal verbs into several groups, including locatum verbs like sugar in (23a) and location verbs like bag in (23b).

- (23) a. to SUGAR the tea 'to put SUGAR in the tea'
b. to BAG the groceries 'to put the groceries
in the BAG'

Drawing on the paraphrases indicated in (23), we can say that the locatum verbs incorporate the parent noun as Theme, the location verbs the parent noun as Goal. The following list provides a few examples of locatum and location denominal verbs.³

Locatum Verbs

- (24) to SUGAR the tea, to POWDER her face,
to PAINT the wall, to BUTTER the bread

Location Verbs

(25) to BAG the groceries, to SHELVE the books,
to LODGE the guests, to BOTTLE the wine

(Buck 1993:140)

Buck (1993) observes that locatum verbs involve more than the mere change of location that location verbs express. Consider the location verb bag in (26).

(26) Bill bagged the groceries.

The groceries moved from an unmentioned initial location to the specified final location, bag. But the bag is not changed or affected in any way. Its inherent properties remain independent of the Theme the groceries, even though the Theme has moved with respect to it.

This does not hold of the locatum verb spice in (27).

(27) Dave spiced the food.

The Theme spice, upon arriving at the final location food, no longer maintains its independence. The food and the spice in fact become one unit. The food changes; it now acquires the spicy property of the Theme inherent in it.

The locatum verb sugar as in sugar the tea provides an interesting support for this semantic distinction between the two classes of denominal verbs. If sugar conveyed the notion of change in location only, then cup rather than tea would be a preferred and perfectly acceptable place object. But it is not.

(28) *He sugared the cup.

Buck argues that (28) is ill-formed because the place object of locatum verbs must be a member of a set of objects that can be affected or changed by the Theme in such a way that

the Theme may become a descriptive property of the place object. But since putting sugar in a cup establishes just a locative relation between two independent objects, the Theme sugar neither affects the cup nor becomes a descriptive property of the cup.

Buck further illustrates the distinction between locatum and location verbs with their passives. The past participle of locatum passives expresses a characteristic or property of the subject as in (29a), while that of location passives a place location as in (29b).⁴

- (29) a. The wall was painted.
b. The books were shelved.

If we ask descriptive questions of the place noun phrase, such as "What was a characteristic of X?", locatum passives will more appropriately answer the question than location passives.

- (30) a. What was a characteristic of the wall?
The wall was painted.
b. What was a characteristic of the shelf?
-

On the other hand, if we ask a location question of the Theme noun phrase, such as "Where did X go?", location passives provide the more appropriate reply.

- (31) a. Where did the wall go? — *It was painted.
b. Where did the books go? — They were shelved.

All this indicates that locatum verbs express change of state, while location verbs change of location, parallel to the two variants of the locative alternation verbs like load or spray. That is, although both of the two classes of

denominal verbs are apparently paraphrasable by put, they are represented differently. Locatum verbs are to be analyzed as "to cause to come to be in state", and location verbs as "to cause to go".

- (32) a. X paint Y
 [CAUSE([X],[INCH[BE([PAINT],[ON Y]])]])]
- b. X shelve Y
 [CAUSE([X],[GO([Y],[TO ON SHELF]])]]

These conceptual structures are related to different syntactic frames via the syntax-semantics correspondences argued for so far. The PPs containing the parent nouns are incorporated into the verbs, yielding the surface forms:

- (33) a. X cover Y with PAINT -> X PAINT Y
 ↑
 └──────────┘
- b. X put Y into SHELF -> X SHELVE Y
 ↑
 └──────────┘

That locatum and location verbs possess the syntactic frames of cover and put, respectively, is supported by the fact that the PPs may actually appear under appropriate conditions. Green (1974) observes that the sentence in (34) as it stands is unacceptable because of redundancy. But when the with-phrase succeeds in adding nonredundant information, it can occur without any oddity as in (35).

- (34) She painted the woodwork with paint.
- (35) She painted the woodwork with { red paint.
 } paint I sold her.

(Green 1974:222)

Jackendoff (1990) makes essentially the same observation that the incorporated Theme may appear in the with-phrase.

(36) We buttered the bread with cheap margarine/with soft, creamy unsalted butter.

(Jackendoff 1990:164)

The with-phrase is felicitous only if it adds nonredundant information. The sentences in (37), failing to contribute additional information, sound odd.

- (37) a. ?We buttered the bread with butter.
b. ?We buttered the bread with something.

(Ibid.:165)

The same holds of location verbs.

- (38) a. Fred bottled the wine in tall green bottles/*in bottles.
b. Herb deftly pocketed the money in his left pocket/*in his pocket.
c. We finally packaged the potato chips in air-cushioned packets/*in packages.

(Ibid.:170)

Thus the same process operates on the two classes of denominal verbs: The PP is incorporated; the direct object position remains intact.

- (39) a. X cover Y with Noun -> X V-Noun Y
b. X put Y into Noun -> X V-Noun Y

This is not surprising considering the role the direct object position plays in various linguistic phenomena: The direct object position is typically connected with affectedness, and being the direct internal argument is a prerequisite for certain category-changing derivations (See Itoh (1981), Levin

and Rappaport (1986), Endo (1986), Iwata et al. (1987), Takizawa (1987), Carrier and Randall (1992)).

The construction approach can account for location and locatum verbs as it does locative alternation verbs. The diagram in (40) illustrates how the denominal verb butter is obtained.

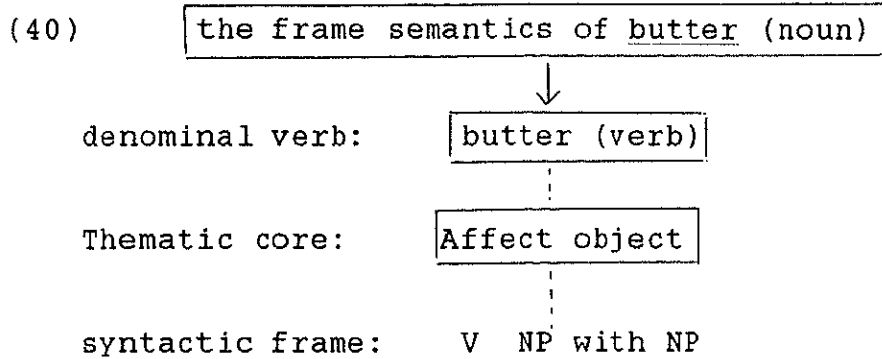

There are several possible constructions to choose from. Now the frame semantics of butter includes the information that butter is typically spread on bread. The event type compatible with this information is chosen, yielding the syntax and semantics of the with-variant. The with-PP is subsequently incorporated, and the denominal verb butter results as in (41).

(41) X butter Y
 [CAUSE([X],[INCH[BE([BUTTER],[ON Y]])]])]

The parallelism between location and locatum verbs on the one hand and locative alternation verbs on the other does not end here. Location and locatum verbs include a class of privative verbs, which express the meanings of 'to take away' or 'to remove' one thing from another.

Locatum Privative Verbs

(42) to pit the cherries, to skin the rabbit

Location Privative Verbs

(43) to mine the gold, to quarry the marble

Evidently these privative verbs correspond to verbs of removal in 3.2., and have conceptual structures in (44).

- (44) a. X skin Y
[CAUSE([X],[INCH[NOT BE([SKIN],[ON Y]])]])]
b. X mine Y
[CAUSE([X],[GO([Y],[FROM MINE]])]]

Thus location and locatum verbs can be accounted for by means of the same mechanisms that handle form-meaning correspondences of 'ordinary' verbs.

3.3.2. Vagaries of Denominal Verbs

An important characteristic of denominal verbs is that they are often open to multiple interpretations. Clark and Clark (1979) observe that the verb shelve is ambiguous between the two meanings as in (45).

- (45) a. shelve the books
b. shelve the closet (Clark and Clark 1979)

Similar examples are abundant. The verb milk may mean either 'to put milk into the tea' or 'to get milk from the cow' as in (46a), and the verb sugar either 'to put sugar into the tea' or 'to coat the fruit with sugar' as in (46b).

- (46) a. milk the tea/milk the cow
b. sugar the tea/sugar the fruit (Ibid.)

Lawler (1989) likewise observes that the verb seed in (47a) means 'to put seeds into the lawn', while in (47b) it means 'to take seeds out of the pepper'.

- (47) a. He was seeding the lawn.
 b. He was seeding the pepper. (Lawler 1989:401)

The vagaries of denominal verbs are straightforwardly accounted for in my approach. As argued above, our knowledge of the real world determines which construction a denominal verb enters into. Thus the frame semantics of shelf allows the verb shelve to acquire the status either as a location verb (shelve the books) or as a locatum verb (shelve the closet).

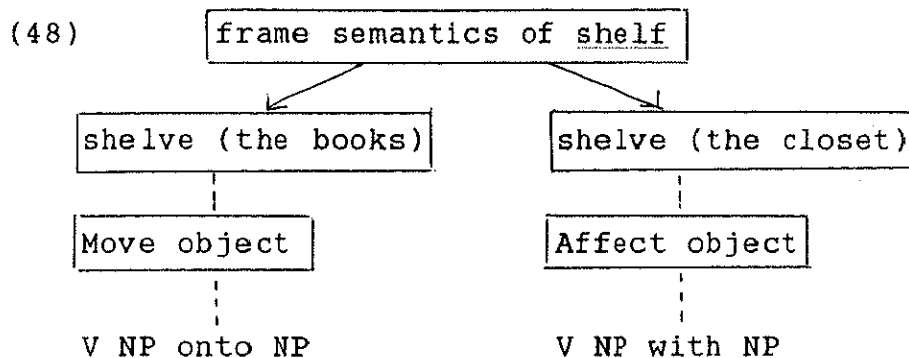

The ambiguity of shelve is parallel to locative alternation. In both cases, a verb can appear in a given syntactic frame, provided the constructional meaning matches the frame semantics of the verb or its parent noun.⁵

Note that the parallelism is captured by my construction-based approach, but not by the lexical extension approach. With locative alternation verbs, the multiple senses are related via a temporally contiguous causal relationship, which gives some credibility to the putative means relation. With denominal verbs, however, no comparable relationship holds between the multiple senses. Even the proponents of the lexical rule approach do not attempt to relate the two senses of shelve by appealing to a means relation or its analogue. This argues once again for my construction-based approach.

3.4. Causative Alternation

Levin and Rappaport (1994, 1995) address the question of when a verb exhibits both an intransitive use and its causative transitive counterpart and when it does not. They distinguish between 'internally' and 'externally' caused eventualities, arguing that verbs which denote the former are limited to intransitive uses. 'Internal causation' means that some property inherent in an argument of the verb is 'responsible' for bringing about the eventuality. Verbs of emission, which generally do not have a causative use, exemplify internal causation.

- (49) a. The jewels glittered/sparkled.
b. *The queen glittered/sparkled the jewels.
(Levin and Rappaport 1994:40)

It is an internal physical property of the subject which brings about the eventualities denoted by these verbs.

On the other hand, verbs denoting externally caused eventualities have transitive uses. They may have intransitive uses as well, as shown in (50).

- (50) a. The vase broke./Antonia broke the vase.
b. The door opened./Pat opened the door.

Levin and Rappaport thus characterize what is called 'causative alternation' like (50) as arising from a detransitivizing process, on the assumption that the transitive use is basic with these verbs. They claim that the detransitivizing process is sensitive to the nature of the eventuality which the verb denotes:

the transitive verbs that detransitivize are those in which the eventuality can happen spontaneously without the volitional intervention of an agent.

(Levin and Rappaport 1994:61)

Verbs that require an animate intentional and volitional agent as subject, such as murder and assassinate or the verbs of creation write and build lack an intransitive variant.

- (51) a. The terrorist assassinated/murdered the candidate.
b. Tony wrote a letter to the editor of the local newspaper.
c. That architect also built the new high school.

(Levin and Rappaport 1994:61)

- (52) a. *The candidate assassinated/murdered.
b. *The letter wrote.
c. *The house built.

(Levin and Rappaport 1994:62)

Levin and Rappaport's claim can be summarized as in (53).

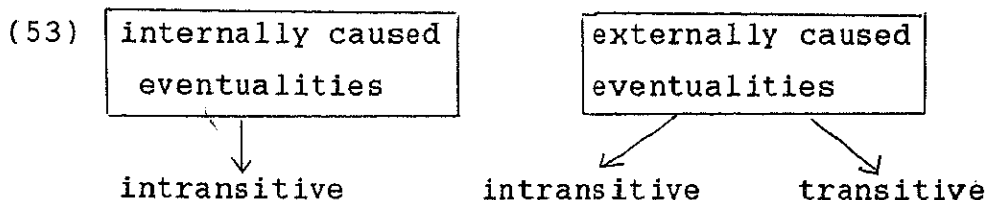

Verbs denoting internally caused eventualities have intransitive uses alone, whereas verbs denoting externally caused eventualities may or may not have both intransitive and transitive uses.

Notice that Levin and Rappaport's account can be recast in my framework, although they are assuming a different form-meaning correspondence model.⁶ In talking about whether the eventuality which a verb denotes can happen spontaneously or not, they are making crucial reference to frame semantic meanings of a verb, although they do not use the term 'frame semantics'. This point becomes clearer when we look at

further examples.

Shudder can be used only intransitively as shown in (54a-b), contrasting with shake, which allows both transitive and intransitive uses.

- (54) a. Mary shuddered.
b. *The green monster shuddered Mary.
c. The green monster made Mary shudder.

(Smith 1970:(35a-c))

Levin and Rappaport attribute this difference to the eventualities which the two verbs describe, saying that shaking is externally caused while shuddering is internally caused. As support for this characterization, they observe that the things which can shake and those which can shudder are not the same:

Things that shudder usually can be thought of as having a 'self-controlled' body; they include people, animals, and, perhaps by forced extension, the earth or a car. In contrast, leaves, teacups, or furniture can only shake.

(Levin and Rappaport 1994:49,fn.13)

Next, verbs like homogenize or pasteurize have transitive, but not intransitive, uses.

- (55) a. The farmer homogenized/pasteurized the milk.
b. *The milk homogenized/pasteurized.
(56) a. Carla humidified her apartment.
b. *Her apartment humidified.

(Levin and Rappaport 1994:63)

Levin and Rappaport argue as follows:

Most of these verbs cannot detransitivize, we propose,

because they describe eventualities such as being pasteurized or homogenized that cannot come about spontaneously without the external intervention of an agent. (Levin and Rappaport 1994:63)

In contrast, those verbs which allow for this possibility do have intransitive variants.

- (57) a. I solidified the mixture./The mixture solidified.
b. The cook caramelized the sugar./
The sugar caramelized.

(Levin and Rappaport 1994:63)

The subtle meaning differences between shuddering and shaking, or between homogenizing/pasteurizing and solidifying/caramelizing, are the same as those between loading and pouring in that they pertain to frame semantic meanings.

In fact, Levin and Rappaport, in accounting for why some verbs have intransitive uses only for certain choices of patient, explicitly state that what distinguishes between internal and external causation is world knowledge. Clear exhibits the following contrast.

- (58) a. The men cleared the table/the sidewalk.
b. *The table/sidewalk cleared.
(59) a. The wind cleared (up) the sky.
b. The sky cleared (up).

(Levin and Rappaport 1994:65)

Their account goes as follows:

Our knowledge of the world tells us that tables and sidewalks are things that are cleared (of dishes and snow, respectively) through the intervention of an animate agent. The sky, however, can clear through the

intervention of natural forces, such as the wind.

(Levin and Rappaport 1994:65)

Thus an adequate account of causative alternation, like that of locative alternation, must make essential reference to frame semantic meanings of a verb.

Note further that transitive and intransitive forms are associated with their respective semantics. Levin and Rappaport claim that a transitive use is possible when the eventuality is externally caused, whereas an intransitive use is obtained either (a) when the eventuality is internally caused or (b) when the eventuality is externally caused but the change of state can come about sporadically as if without the intervention of an animate causer. This amounts to saying that an intransitive use is obtained when a change of state can come about 'naturally', irrespective of whether that change of state in itself constitutes an eventuality or it forms part of a larger eventuality. Consequently, it is possible to treat the causative alternation parallel to the locative alternation, as shown in (60).

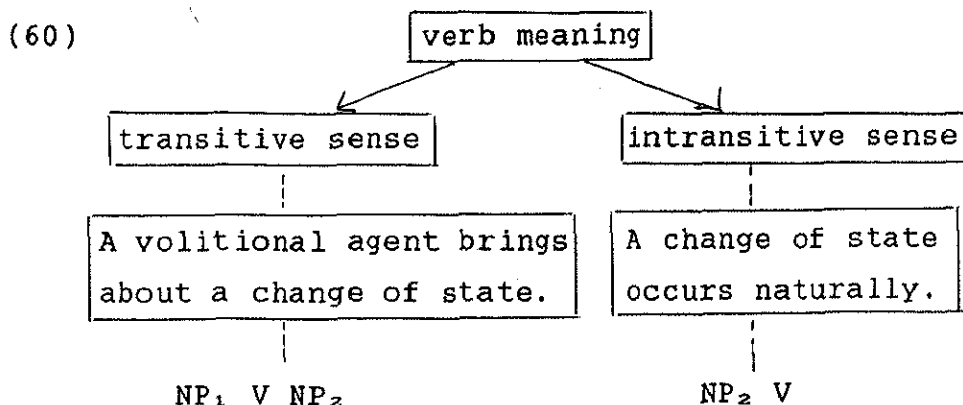

As Levin and Rappaport argue, the phenomena that fall under the label 'causative pair' are actually heterogeneous, involving a number of different processes,⁷ and I concede that not all the transitive/intransitive pairs fit the pattern of (60). Nevertheless, it seems safe to say that

transitive and intransitive forms are associated with their specified meanings, constituting constructions.

3.5. Multiple Direct Objects

3.5.1. Choice of Object

Not only locative alternation verbs can take multiple NP PP frames, but some verbs allow choice of direct object even with a sole NP complement. Some of these cases can be treated like locative alternation.

As seen in 2.2.1, Fillmore (1971) observes that verbal polysemy may develop via a temporally contiguous causal relationship.

Where one kind of activity is a possible way of carrying out another kind of activity, the verb which identifies the former activity has superimposed onto it certain syntactic and semantic properties of the verb which identifies the second or completing activity.

(Fillmore 1971:385)

Fillmore cites the different senses of tie, besides locative alternation, as an instance resulting from this process. The verb tie refers to particular kinds of manipulation of string-like objects and occurs in sentences (61a) and (61b).

(61) a. He tied his shoestrings.

b. He tied the knot. (Fillmore 1971:385)

Now the act of tying things can lead to fastening things, so that tie comes to acquire the syntax and semantics of fasten. Thus tie can appear as in (62), although shoes are not in themselves the kinds of object that one manipulates when tying knots.

(62) He tied his shoes. (Fillmore 1971:386)

If Fillmore's observation is correct, these different direct objects should carry subtle meaning differences. This is confirmed by Langacker's (1991:356) observation that alternate selections of the direct object reflect different construals of objectively the same scene. He argues that the element coded by the direct object is a focal participant in the event, enhancing the salience of the component relationships that immediately involve it. Commenting on the three expressions in (63), he observes as follows:

(63) He tied {his shoe/his shoelace/a bow with his shoelace}.

For instance, the first option (his shoe) brings into focus those relations involving the shoe as a whole (notably the snugness of its attachment to the foot), whereas the second (his shoelace) highlights relationships pertaining to the lace in particular (e.g. that the ends no longer drag along the ground).

(Langacker 1991:356)

Thus it is possible to say (64) or (65).

(64) He tied his shoe to keep from getting a blister [from the foot rubbing against the inside of the shoe].

(65) He tied his shoelace to keep from tripping [by stepping on the loose ends]. (Ibid.)

However, (66) sounds somewhat less natural.

(66) ?He tied his shoelace to keep from getting a blister.
(Ibid.)

3.5.2. Tie

Let us now analyze multiple senses of tie, based on the observations seen above. Tie can appear in two syntactic frames as in (67).

- (67) a. tie string round a package => tie (A)
b. tie a package with string => tie (B)

This is an instance of locative alternation gestalt shift. One can interpret the act of tying as putting a string-like object around something, but one can also interpret the same act as changing the state of that something.

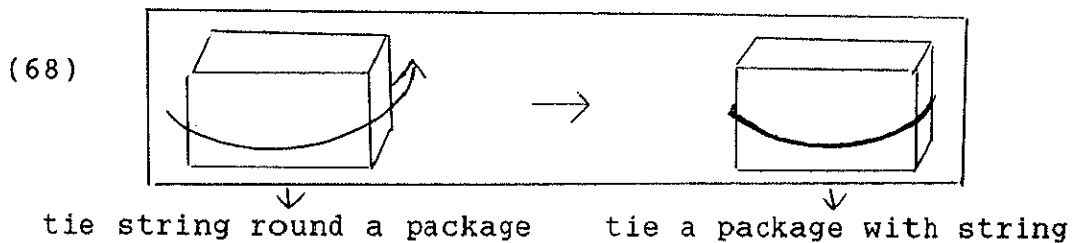

Now tie can appear in a third frame as in (69).

- (69) a. tie a dog to a lamp-post (OALD⁴)
b. We're going to tie this letter to a brick.
 (COBUILD)

How this third locative sense is related to the two senses above becomes apparent when we notice that this sense allows for expression of a string-like entity as well.

- (70) tie a letter to the tree with string

This sense, referred to as tie (C), can be schematically represented as in Fig. 7.

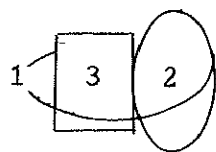

Fig. 7

While tie (C) profiles the three elements 1-3, tie (A) and tie (B) realize two elements 1 and 2. Thus the three senses can be summarized as in (71).

- (71) a. tie NP₁ round NP₂ => tie (A)
- b. tie NP₂ with NP₁ => tie (B)
- c. tie NP₃ to NP₂ (with NP₁) => tie (C)

Other senses of tie can be treated along the same lines. The two senses in (72) and (73), referred to as tie (D) and tie (E), respectively, put in profile a string-like object alone.⁶

- (72) tie his shoelaces => tie (D)
- (73) tie a knot => tie (E)

While tie (D) is obtained by profiling the string as a whole, tie (E) is obtained by focusing on the part where the two ends of the string meet.



Fig. 8

And as Fillmore observes, when the focus shifts from the shoelaces to the shoes, the sense in (74), tie (F), is obtained.

- (74) tie his shoes => tie (F)

The G-network of tie is as shown in Fig. 9.

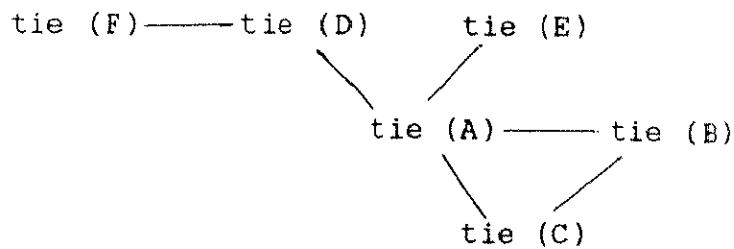

Fig. 9

All the links are effected through "alternate construals" (Langacker (1986)), or a "conceptual gestalt shift" (Pinker (1989)).

Note that here again the network of tie constitutes a challenging problem for the lexical rule approach along the lines of Levin and Rappaport. The means extension analysis plausibly relates tie (A) to tie (B) and tie (D) to tie (F), where the putative derivations parallel the temporal unfolding of the event. Yet it has difficulty handling other links in Fig. 9. One cannot claim that a means relation obtains between tie (B) and tie (C), or between tie (A) and tie (D). Nor does it seem easy to come up with subordinating relations which properly connect the senses.

3.6. Concluding Remarks

It has been shown that many of the G-network senses are better accounted for in terms of constructions than in terms of lexical rules. While "constructions" in my account cover slightly different areas from those intended by Goldberg, it is nevertheless true that certain form-meaning correspondences, independent of particular verbs, partially determine what have traditionally been labelled "subcategorization frames".

At the same time, I hasten to add that the construction-based approach does not lead to the conclusion that distinctions between senses are no longer necessary. Not all the G-network senses can be handled by constructions. Besides, as pointed out in the last chapter, even when a single L-meaning

gives rise to multiple P-meanings, these resulting senses have different lexical properties.

Notes to Chapter 3

1. This entails that the same mechanism operates in both lexical and extra-lexical form-meaning correspondences, which is consonant with Langacker's (1987) claim that lexicon and grammar form a continuum of symbolic structure.

2. Within Jackendoff's framework, CAUSE-GO expresses a change of location, CAUSE-INCH a change of state.

3. For a more extensive list, see Clark and Clark (1979).

4. But this difference per se is not so crucial as Buck claims, for it merely reflects the theta-role of the direct internal argument. Normally the direct internal argument is externalized by passivization, whether verbal or adjectival.

5. This approach seems to be extendable to cases other than locatum and location verbs. Sehnert and Sharwood-Smith (1973) claim that (i) could mean any of (iia-d).

(i) She bottled the wine.

(ii) a. She attacked the wine with a bottle.

b. She covered the wine with a bottle.

c. She contacted the wine with a bottle.

d. She recorded the wine with a bottle.

However, there is usually no problem in interpretation, for every speaker of English is fully aware of the use and limitations placed on the instruments (p.44).

6. They assume a system of two-level lexical representations: a lexical semantic representation (or lexical conceptual structure) and a lexical syntactic representation (or argument structure). Thus the lexical representations of transitive break is schematized as in (i).

(i)

Transitive break

LSR		[[X DO-SOMETHING] CAUSE [Y BECOME BROKEN]]
Linking rules	↓	↓
Argument structure X		Y

7. Levin and Rappaport (1995:115) argue that what they call idiosyncratic pairs as in (i) and what they call spurious causative pairs as in (ii) and (iii) are not instances of causative alternations as they define it.

(i) a. The baby burped.

b. The nurse burped the baby.

(ii) a. The doorbell buzzed/rang.

b. The postman buzzed/rang the doorbell.

(iii) a. The flashlight beamed/shone.

b. We beamed/shone the flashlight.

8. It may be possible to analyze tie (D) as involving a reflexive path, where a Theme and a reference object coincide (See Lindner (1982, 1983), Lakoff (1987)).

Chapter 4

Motion and Extent: Two Sides of the Same Coin*

4.0. Introduction

This chapter is concerned with the contrast in (1). The English verb go expresses the subject's motion in (1a) but the subject's extent in (1b).

- (1) a. Amy went from Denver to Indianapolis.
b. Highway 36 goes from Denver to Indianapolis.

In order to express the intuition that the senses of motion and extent are related, Jackendoff (1983:173) resorts to two semantic functions. In contrast to the GO-function for a motion sentence as in (2a), Jackendoff posits a function GO_{Ext} for an extent sentence as in (2b).

- (2) a. [Event GO ([Thing X],[Path Y])]
b. [State GO_{Ext} ([Thing X],[Path Y])]

While this analysis captures the fact that motion go and extent go are related, exactly how they are related is left unaccounted for. Jackendoff (*ibid*) suggests two possibilities concerning the relatedness of GO and GO_{Ext}. First, GO and GO_{Ext} are not distinct functions and the difference depends only on whether the GO function is a feature of an [EVENT] or a [STATE]. Alternatively, the functions are distinct but share a great deal of internal structure.

Although Jackendoff does not choose between the two possibilities, the first seems difficult to maintain for two reasons. First, an important characteristic accompanying the motion/extent contrast is the difference in the character of the subject, namely, a moving, point-like object vs. a static, elongated object. If the Event/State contrast is really the sole distinguishing factor, then the different

characters of the subject should automatically follow from this contrast. But this does not seem to be the case. Without an account of their correlation with the Event/State contrast, then, the characters of the subjects would have to be independently stipulated as idiosyncratic properties of the two functions.

The next reservation is closely connected with the first. Jackendoff (1990:92) observes that (3a) can describe either the past extent of the railroad, as in (3b), or a stage in the construction of the railroad, as in (3c).

- (3) a. The railroad reached Kansas City.
- b. The railroad used to reach Kansas City, till they tore it up.
- c. The railroad finally/soon reached Kansas City.

The extent reading in (3b) describes a State, and the "stage of construction" reading in (3c) an Event that is evidently the inchoative of the State: "the railroad finally/soon came to reach Kansas City." Here the Event/State distinction is not sufficient to correctly express the meanings. While the State reading in (3b) can be expressed by GO_{Ext} , the Event reading in (3c) cannot be created by substituting GO for GO_{Ext} ; the resulting reading would be "the railroad traveled/moved to Kansas City," clearly an incorrect result.

These considerations argue in favor of the second possibility rather than the first.¹ In the following discussion we will examine closely how GO and GO_{Ext} are related, building upon Jackendoff's (1983) analysis.

4.1. Analysis

4.1.1. Basic Characteristics

Let us begin by observing several basic characteristics of extent sentences. First, quite a wide range of path expressions are possible in extent sentences. As Jackendoff

(1983:172) points out, bounded paths (4a), directions (4b), and routes (4c) are all allowed, and no restrictions seem to be imposed upon path expressions.

- (4) a. The highway extends from Denver to Indianapolis.
- b. The flagpole reaches (up) toward the sky.
- c. The sidewalk goes around the tree.

This means that the extent interpretation is independent of the choice of prepositions. It thus seems correct to hold the verb responsible for the motion/extent contrast.

Next, a large number of verbs exhibit the motion/extent contrast. Binnick (1968) observes that cross, enter, and follow can serve either an active, motive verb as in (5), or a stative, locative verb as in (6).

- (5) a. Caesar crossed the English Channel.
- b. The announcer entered the studio.
- c. James Bond followed the enemy spy.
- (6) a. Route 80 crosses Iowa.
- b. The railroad enters the town near the post office.
- c. 'B' follows 'A' in the alphabet.

Remarkably, these sentences can be paraphrased by means of go (come), irrespective of the contrast in question, as in (7) and (8).

- (7) a. Caesar went (came) across the English Channel.
- b. The announcer went (came) into the studio.
- c. James Bond went (came) after the enemy spy.
- (8) a. Route 80 goes (comes) across Iowa.
- b. The railroad goes (comes) into the town near the post office.
- c. 'B' goes (comes) after 'A' in the alphabet.

(Binnick 1968)

Third, GO expresses an Event, while GO_{EXT} a State, which is confirmed by the three diagnostics that Jackendoff (1983) proposes. First, the extent sentence can occur in the simple present tense and refer to the present time as in (9b), thereby qualifying as a State. It is true that the motion sentence may occur in the simple present tense, but only under special interpretations. Thus the sentence in (9a) is acceptable when construed as expressing either generic events (every day), or a future event (tomorrow).

(9) a. Harry goes from New York to Hartford (every day/
tomorrow).

b. Route 87 goes from New York to Hartford.

(Jackendoff 1979:175)

These special uses of the present tense must be clearly distinguished. In fact, the generic present tense is not possible with extent sentences.

(10) *Route 87 goes from New York to Hartford every day.

(ibid.)

Next, with events but not with states progressive aspect is allowed. The motion sentence, but not the extent sentence, can appear in the progressive aspect.

(11) a. Harry is going from New York to Hartford.

b. *Route 87 is going from New York to Hartford.

(acceptable only to describe the road's being
built) (ibid.)

Finally, events, but not states, can occur after "What happened was (that) ..." Here again, the motion sentence, but not the extent sentence, passes the test.

(12) a. What happened was that Harry went from New York to Hartford.

b.*What happened was that Route 87 went from New York to Hartford. (ibid.)

All these facts confirm the representations in (2): The same range of path expressions occur in both motion and extent sentences, indicating that paths are not responsible for the motion/extent contrast. Second, given that the motion/extent contrast is observable among many motion verbs, it is reasonable to posit a general GO_{EXT} function. Finally, a motion sentence expresses an Event and an extent sentence a State.

4.1.2. A Succession of Transitions

Next, let us compare the situations described by the two functions. To borrow Jackendoff's (1983:173) apt phrasing, in a motion sentence "the subject is asserted to have traversed the path, covering each point of the path in order over time," whereas in an extent sentence "the subject is asserted to occupy the entire path at a single point in time." Accordingly, GO and GO_{EXT} are represented as Figs.1 and 2, respectively.

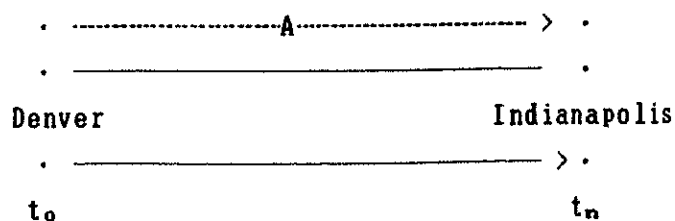

Fig.1.

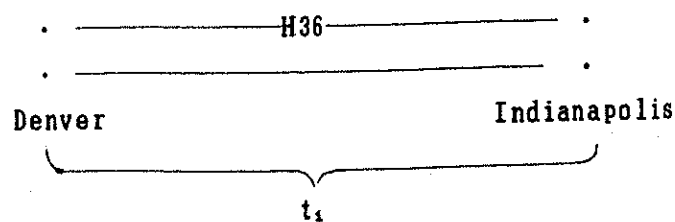

Fig.2.

Fig.1 consists of three lines. The topmost line designates the mover, where A stands for Amy, our traveler in (1). The middle and the bottom lines are the spatial path and the time line, respectively. Arrows are employed for the mover and time lines to express directionality. The path is depicted by a straight line because the path leading from Denver to Indianapolis has no inherent directionality. The mover line is expressed as a dotted line in order to emphasize the succession of changes of locational state from one unit of time to the next. By contrast, in Fig.2 H36 stands for Highway 36. Neither the road nor the path has inherent directionality, so that both are represented by unbroken lines. The road occupies the entire path at a single point in time (t_1).

Now when we divide the path and the time line into a sequence of indefinitely many points, we get Fig.3.

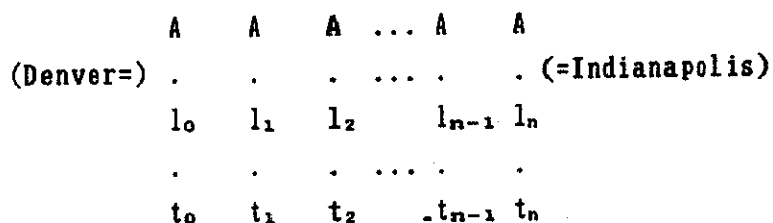

Fig.3

Amy proceeds on the path, which is a linearly ordered set of points in space that starts with Denver ($=l_0$) and ends with Indianapolis ($=l_n$). Amy's movement also involves a bounded sequence of moments of time $\langle t_0, \dots, t_n \rangle$. At each of these moments of time $t_0 < t_1 < t_n$, Amy is at l_1 .

Fig.2 can be similarly treated. Both Highway 36 and the path from Denver to Indianapolis can be divided into an ordered set of points.

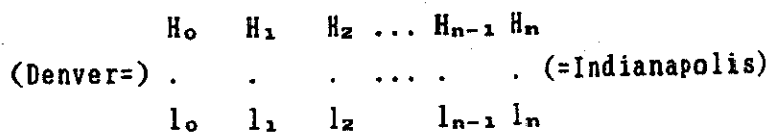

Fig.4

The road and the path being coextensive, each point of the road $H_1 < H_1 < H_n$ is at a spatial position l_1 .

Thus Amy's movement along the path and the road's occupying the entire path are captured in terms of a sequence of component states as in (13a) and (13b), respectively.

$$(13) \text{ a. } \begin{bmatrix} A \\ l_m \\ t_m \end{bmatrix} \Rightarrow \begin{bmatrix} A \\ l_{m+1} \\ t_{m+1} \end{bmatrix} \qquad \text{b. } \begin{bmatrix} H_m \\ l_m \end{bmatrix} \Rightarrow \begin{bmatrix} H_{m+1} \\ l_{m+1} \end{bmatrix}$$

(13a) and (13b) clearly show that GO and GO_{Ext} are similar. Both express a chain of transition from one component state to another. Also, in both cases the subject is related to a spatial location in each component state, although they differ as to whether it is the subject as a whole (13a) or only a portion of the subject (13b) in each of those component states.²

Interestingly enough, this difference is closely related to another difference between (13a) and (13b), i.e., the presence vs. absence of the passage of time. Recall that time has inherent directionality: It always flows from the past through the present to the future. The time flow being incessant, the moment one is aware of the present moment, the "present" instantly vanishes. That is, a given moment (t_m) and the immediately succeeding moment (t_{m+1}) are necessarily distinct from each other, and are mutually exclusive: The existence of one necessarily entails the non-existence of the other. This transient nature of time is reflected in each component state of GO, $\langle A_1, l_1, t_1 \rangle$, where the mover and a point on the spatial path are associated with a point on the time line. Thus component states are also distinct from each other, and are mutually exclusive. No component state can coexist with another. This is expressed as in (14).

$$(14) \qquad t_{m+1} \supset \sim t_m$$

$$\Rightarrow \langle A, l_{m+1}, t_{m+1} \rangle \supset \sim \langle A, l_m, t_m \rangle$$

On the other hand, no such restriction is imposed upon the transition denoted by GO_{Ext} , so that all the component states can coexist. Consequently, coordinated subcomponents form a line. The subject in a motion sentence, then, is a moving, point-like object, but that in an extent sentence a static, elongated object.

Furthermore, note that the Event/State distinction is a consequence of the presence/absence of the passage of time associated with the transition. Events, unlike States, indicate a change through time. Therefore GO , whose transitions proceed in time, necessarily expresses an Event. In contrast, the transition denoted by GO_{Ext} lacks reference to the passage of time, so that GO_{Ext} does not express a change over time.³

The discussion thus far has established that both GO and GO_{Ext} denote a succession of transitions from one component state to the next. Their most crucial difference is associated with the presence/absence of the passage of time, which on the one hand determines the Event/State distinction, and on the other is indirectly related to whether the subject occupies a single point or the entire path.⁴

4.1.3. Eventive GO_{Ext}

An important consequence of our explanation is that GO_{Ext} is not inherently a State function. If so, then it should be possible for GO_{Ext} to express an Event as well as a State. This is in fact borne out.

One great advantage of formalization by means of conceptual structure is that it is capable of capturing cross-field lexical generalization. This is also true of GO_{Ext} . Jackendoff (1983) argues that the following are instances of GO_{Ext} applied to non-spatial semantic fields.

Temporal field

(15) Ron's speech went/extended/lasted from 2:00 to 4:00.

Identificational field

(16) a. Our clients range from psychiatrists to psychopaths.

b. This theory ranges from the sublime to the ridiculous. (Jackendoff 1983:196)

Clearly the sentences in (16) express States, as witnessed by their compatibility with simple present tense. But notice that (15) expresses an Event, as shown by the "What happened was" test.

(17) What happened was that Ron's speech went from 2:00 to 4:00.

It might be objected that (15) is an instance of GO, not GO_{Ext}. But there is evidence that (15) is in fact an instance of GO_{Ext}. Jackendoff (1976:139) formalizes different inference rules (18a) and (18b) for GO and GO_{Ext}, respectively, which are intended to capture the different characters of the subject NP.⁵

(18) a. $\left[\begin{array}{c} \text{GO}_{\text{Trans}} (X, Y, Z) \text{ AT } t_1 \\ W \end{array} \right] \Rightarrow$ for some times t_2 and t_3 such that $t_2 < t_1 < t_3$,
 $\left[\begin{array}{c} \text{BE}_{\text{Trans}} (X, Y) \text{ AT } t_2 \\ W \end{array} \right]$ and $\left[\begin{array}{c} \text{BE}_{\text{Trans}} (X, Z) \text{ AT } t_3 \\ W \end{array} \right]$

b. $\left[\begin{array}{c} \text{GO}_{\text{Ext}} (X, Y, Z) \\ W \end{array} \right] \Rightarrow$ for some T and U such that $T \subset X$ and $U \subset X$,
 $\left[\begin{array}{c} \text{BE}_{\text{Ext}} (T, Y) \\ W \end{array} \right]$ and $\left[\begin{array}{c} \text{BE}_{\text{Ext}} (U, Z) \\ W \end{array} \right]$

(18a) means that at the beginning of the event (t_2), the subject (X) is at Y, and at the end, (t_3), at Z. By contrast,

(18b) indicates that the subject (X) concurrently occupies all points within the path (from Y to Z).

Now let us examine the temporal use in (19) by means of these inference rules.

(19) The conference went/lasted/extended from Tuesday to Friday.

Only inference rule (18b) is applicable: we can infer that part of the conference was on Tuesday and part on Friday; it makes no sense to apply (18a) and infer that there was a time at which the conference was on Tuesday and a time at which it was on Friday (Jackendoff 1976:139-41). If anything, the inference rule (18a) is applicable to sentences like (20).

(20) We moved the meeting from Tuesday to Thursday.
(Jackendoff 1983:190)

(20) conveys that the meeting was first scheduled to be on Tuesday, but the date was later changed.⁶

All this indicates that (19) is an instance of GO_{Ext} . Here the GO_{Ext} function expresses an Event, in contradiction to the representation in (2b). An explanation why GO_{Ext} may denote an Event is to be found in Bennett (1975), who attributes the eventive character of (21) to the inherent nature of time.

(21) The film lasted from seven o'clock to nine o'clock.

... owing to the unidirectionality of time, it is impossible to occupy an extent of time without moving it from the beginning to the end. (Bennett 1975:98)

This can be represented as in Fig.5.



Fig.5

Crucially, the spatial path is replaced by the temporal path. It is the passage of time thereby introduced which renders the whole situation eventive.

This is coherent with our claim that the Event/State distinction follows from the presence/absence of the passage of time. GO_{Ext} normally expresses a State, but this is not because GO_{Ext} is inherently stative but rather because the passage of time is lacking. If the passage of time is introduced into GO_{Ext} in one way or another, the sentence becomes eventive.

The following pair taken from Langacker (1987:88) can be explained along the same line.

- (22) a. This road winds through the mountains.
- b. This road is winding through the mountains.

The verb wind appears in simple present tense and expresses a State in (22a). But it may also occur in the progressive aspect as in (22b). Langacker observes that the sentences are appropriate in different contexts: (22a) might be used in planning a trip or examining a road map, while (22b) reports on what one actually experiences while driving along the road.⁷ In other words, in (22b) the viewer (who is the speaker of this sentence in this case) himself is in motion, so that the situation is perceived as dynamic and therefore as an Event. Call it a viewer-in-motion reading. In this reading the passage of time accompanying the viewer's motion is superimposed as in Fig.6.

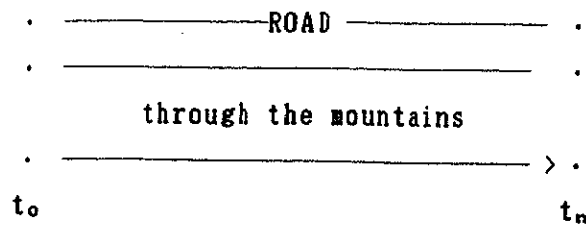

Fig.6.

That the verb is eventive in the viewer-in-motion reading is further confirmed by Mittwoch's (1990) observation about the extent sentences in (23).

- (23) a. The valley narrows to a precipitous gorge.
 b. The road widens to a dual carriage-way.

(Mittwoch 1990:106)

Mittwoch observes that when these sentences appear as bare infinitive complements after perception verbs as in (24), the whole sentences are appropriate if the viewer himself is in motion but inappropriate if a stationary viewer looks down on the entire scene from some commanding height.

- (24) a. I saw the valley narrow to a narrow (sic) gorge.
 b. I saw the road widen to a dual carriage-way.

(Ibid.)

This is more clearly seen in the following contextualized version.

- (25) As you drive along, you'll be surprised at the way you can see the valley narrow to a precipitous gorge. (Ibid.)

Only the viewer-in-motion reading is allowed in the perception-verb complement position, which is generally held to be limited to Events.⁶

Therefore, GO_{EXT} can express an Event as well as a State,

provided conditions are met. This challenges Jackendoff's formulation (2b), which is based on the assumption that GO_{Ext} is inherently a State function. Consider the following formation rules (Jackendoff (1983:174)), where [EVENTS] and [STATES] are elaborated into functions.

- (26) a. [EVENT] -> [Event GO([Thing X],[Path Y])]
 [Event STAY([Thing X],[Place Y])]
 b. [STATE] -> [State BE([Thing X],[Place Y])]
 [State ORIENT([Thing X],[Path Y])]
 [State GO_{Ext} ([Thing X],[Path Y])]

These rules indicate that GO_{Ext} is inherently a State function. But as seen above, the stativity of GO_{Ext} is due to the absence of (specific) passage of time. In order to capture the derivative character of GO_{Ext}'s stativity, therefore, it is necessary to develop a theory in which the Event/State distinction is orthogonal to the functional classification.

4.2. Other Approaches

We have thus far analyzed the motion/extent contrast in terms of semantic functions, following Jackendoff (1983). Analyses have been advanced which account for the motion/extent contrast by means of various mechanisms. In this section, we will turn to three of these approaches and examine how they compare with our analysis.

4.2.1. Langacker (1986, 1987a, 1987b)

Within the framework of Cognitive Grammar (Langacker 1986, 1987a, 1987b), two kinds of mechanisms are called for to account for the motion/extent contrast. First, Langacker distinguishes two modes of cognitive processing: summary vs. sequential scanning. The sequential scanning of a complex relation is formulated in this way:

$$(27) \begin{bmatrix} a \\ C \end{bmatrix}_{T_1} > \begin{bmatrix} b \\ C \end{bmatrix}_{T_2} > \begin{bmatrix} c \\ C \end{bmatrix}_{T_3} > \begin{bmatrix} d \\ C \end{bmatrix}_{T_4}$$

At moment T_1 of processing time, the conceptualizer C activates the conception of state a ; at T_2 , he activates conception b ; and so on. The crucial point is that each conception begins to decay as the next one is activated, so that only one is fully active at any one instant. In summary scanning, by contrast, each state remains active as the next one in the series is accessed:

$$(28) \begin{bmatrix} a \\ C \end{bmatrix}_{T_1} > \begin{bmatrix} a \\ b \\ C \end{bmatrix}_{T_2} > \begin{bmatrix} a \\ b \\ c \\ C \end{bmatrix}_{T_3} > \begin{bmatrix} a \\ b \\ c \\ d \\ C \end{bmatrix}_{T_4}$$

The resulting conception grows progressively more complex, so that finally (at T_4) all the component states are superimposed and simultaneously active (Langacker 1986:460).

Second, verbs are divided into two basic classes, namely perfectives and imperfectives, which correspond respectively to Events and States in the terminology of Jackendoff. A perfective process portrays a situation as changing through time, so that each component state (r) is different from the other as in (29).

$$(29) \begin{bmatrix} [r_1]t_1 \\ C \end{bmatrix}_{T_1} > \begin{bmatrix} [r_2]t_2 \\ C \end{bmatrix}_{T_2} > \dots > \begin{bmatrix} [r_n]t_n \\ C \end{bmatrix}_{T_n}$$

By contrast, an imperfective process describes the extension through time of a stable situation, so that all the component states are identical (R):

$$(30) \quad > \begin{bmatrix} [R]t_1 \\ C \end{bmatrix}_{T_1} > \begin{bmatrix} [R]t_3 \\ C \end{bmatrix}_{T_3} > \begin{bmatrix} [R]t_k \\ C \end{bmatrix}_{T_k} >$$

The motion/extent contrast is accommodated by the combination of these two kinds of mechanisms. The motion go expresses an Event (perfective process) in which the mover changes his location in order over time, which indicates that sequential scanning is employed along with the formula for a perfective process. The representation is therefore obtained by substituting for each instance of r_1 in (29) the more specific notation $[m]l_1$, which indicates that the mover m occupies location l_1 .

$$(31) \quad \begin{bmatrix} [[m]l_1]t_1 \\ C \end{bmatrix}_{T_1} > \begin{bmatrix} [[m]l_2]t_2 \\ C \end{bmatrix}_{T_2} > \dots > \begin{bmatrix} [[m]l_n]t_n \\ C \end{bmatrix}_{T_n}$$

In contrast, the extent go expresses a State (imperfective process) in which a static entity occupies an entire path. The configuration of the static entity is first obtained by summary scanning:

$$(32) \quad \begin{bmatrix} [m_1]l_1 \\ C \end{bmatrix}_{T_1} > \begin{bmatrix} [m_1]l_1 \\ [m_2]l_2 \\ C \end{bmatrix}_{T_2} > \begin{bmatrix} [m_1]l_1 \\ [m_2]l_2 \\ [m_3]l_3 \\ C \end{bmatrix}_{T_3} > \dots > \begin{bmatrix} [m_1]l_1 \\ [m_2]l_2 \\ [m_3]l_3 \\ : \\ [m_n]l_n \\ C \end{bmatrix}_{T_n}$$

The resulting configuration at T_n is then substituted for the component state R as a stable situation:

$$(33) \quad \text{--->} \left[\begin{array}{c} [[m_1 \dots n]t_1 \dots n]t_1 \\ C \end{array} \right]_{T_1} > \left[\begin{array}{c} [[m_1 \dots n]t_1 \dots n]t_2 \\ C \end{array} \right]_{T_2} > \text{---}$$

Now let us compare Langacker's analysis with ours. Representations (31) and (33) are quite similar to (13a) and (13b) arrived at in Section 1: Apart from conceptualizer and processing time, both sets of representations convey the idea that in a motion sentence a mover (m) changes his location (l) along with the passage of time, whereas change of location is independent of the passage of time in an extent sentence. The insight underlying Langacker's analysis, then, is the same as that underlying ours. Moreover, Langacker's theory can accommodate non-spatial extent sentences by recourse to the notion of "semantic domains", so that in this respect, too, his analysis and ours are equal.

However, Langacker does not seem to recognize the important role time plays in differentiating motion and extent. Thus Langacker employs the formula for imperfectives (States) for an extent sentence, but offers no explanation why an extent go should be stative; while Langacker correctly points out that each component decays in sequential scanning but remains active throughout in summary scanning, he says nothing about why. Above all, Langacker's failure to recognize the primary role of time is most clearly seen in his analysis of (34).

(34) The concert went from midnight to 4AM.

Langacker (1986:462-63) analyzes (34) by means of sequential scanning as in (35), apparently on the ground that it is eventive.

$$(35) \begin{bmatrix} [[m]t_1]t_1 \\ C \end{bmatrix}_{T_1} > \begin{bmatrix} [[m]t_2]t_2 \\ C \end{bmatrix}_{T_2} > \dots > \begin{bmatrix} [[m]t_n]t_n \\ C \end{bmatrix}_{T_n}$$

Because time serves as an abstract location in (31), t_1 is substituted for location (l_1).

But remember that (34) is an extent sentence, as already pointed out in Section 1: We can infer that part of the concert was at midnight and part at 4AM, but not that there was a time at which the concert was at midnight and a time at which it was at 4AM. The inference pattern is that of an extent sentence, which means summary scanning must be employed.

Consequently, a correct analysis would go as follows: The configuration in the temporal domain, i.e., the temporal length of the concert, is first obtained by substituting t_1 for l_1 in (32). But the inherent nature of time prevents the conception from being cumulative, so that (36) results:

$$(36) [[m_1]t_1] > [[m_2]t_2] > [[m_3]t_3] > \dots$$

This is substituted for component states of (29), yielding (37).

$$(37) \begin{bmatrix} [[m_1]t_1]t_1 \\ C \end{bmatrix}_{T_1} > \begin{bmatrix} [[m_2]t_2]t_2 \\ C \end{bmatrix}_{T_2} > \dots > \begin{bmatrix} [[m_n]t_n]t_n \\ C \end{bmatrix}_{T_n}$$

2.2. Lakoff (1987)

Let us now turn to Lakoff (1987), who analyzes the motion/extent contrast by means of an image-schema transformation.

$$(38) \text{ a. Sam } \underline{\text{went}} \text{ to the top of the mountain. (ODMTR)}$$

- b. The road went to the top of the mountain. (1DTR)

Here a one-dimensional trajector (1DTR) and a zero-dimensional moving trajector that traces a path (ODMTR) are linked by a transformation. Lakoff states the experiential basis for this transformation as follows:

ODMTR <-> 1DTR : When we perceive a continuously moving object, we can mentally trace the path it is following.

Although this analysis is intuitively appealing, several problems crop up. First, the image-schema transformation analysis is not precise about what element undergoes the transformation. Lakoff apparently utilizes the transformation ODMTR <-> 1DTR to account for the two senses of the verb go, but this transformation is not so designed as to cover verb senses alone; he applies it for the following pair as well.

- (39) a. Sam ran through the forest. (ODMTR)
b. There is a road through the forest. (1DTR)
(Lakoff 1987: 442)

So nothing in this analysis guarantees that the motion/extent contrast is a matter of two verb senses.

It might be argued that Lakoff's intent lies in linking two different but related perceptual gestalts, and that the transformation in (39) is meant to convey only the idea that through participates in those gestalt formations.

Even granted that a schema forms a gestalt structure, the application of the transformation to the pair in (39) is still problematic. As stated, (39) can be taken to mean that the preposition through is capable of expressing two senses, i.e., a one-dimensional trajector and a zero-dimensional moving trajector. But the denotation of through the forest is invariant across the two sentences, as shown by Fig.7.

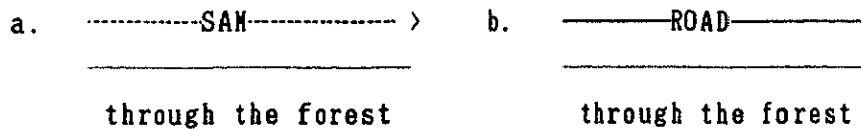

Fig.7.

This is not consistent with Lakoff's contention that image-schema transformations are necessary to motivate polysemy.⁹

Next, Lakoff's analysis captures only one aspect of the motion/extent contrast, the subject's character, and does not constitute an overall characterization of the contrast. It says nothing about the Event/State distinction. Why the sentence should be eventive with a zero-dimensional trajector but stative with a one-dimensional trajector needs to be accounted for.

Lastly, the very characterization of extent sentences by means of a one-dimensional trajector is not without problems. The 0DMTR <-> 1DTR transformation amounts to saying that a sequence of points can be converted into a line as in Fig.8.

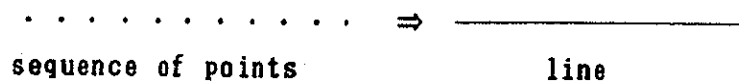

Fig. 8

But this occurs with a one-dimensional path. When the path is two-dimensional, the collection of points turns into a plane as in Fig.9.

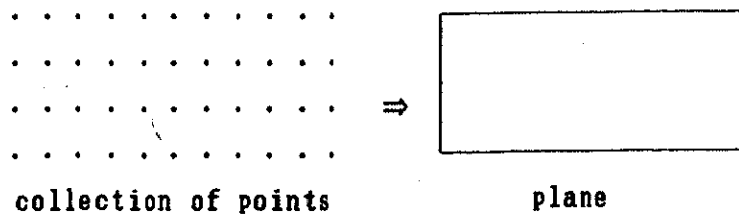

Fig. 9

Therefore, if there is a motion verb with a two-dimensional path, then the subject of its extent counterpart will be also two-dimensional. Such verbs do exist. Spread is a case in

point.

- (40) a. The city spreads for miles to the north.
b. At the foot of the mountain the city spread out to the bay. (COBUILD)

Spread has an extent sense as well as a motion one, parallel to go. But the extent sense of spread, whose subject NP is not one-dimensional, cannot be accommodated by the ODMTR <-> 1DTR transformation. Therefore, Lakoff has to postulate another image-schema transformation ODMTR <-> 2DTR. In other words, two separate transformations will be required for phenomena that are fundamentally the same, certainly an unwelcome result.¹⁰

Thus what is really crucial is that in extent sentences the subject and the path are coextensive, not that a point-like object and a line alternate. We will present a possible analysis of (40) in 3.2.1.

2.3. Lakoff & Turner (1989)

Finally, let us turn to Lakoff and Turner (1989), who analyze the following sentences in terms of the metaphor FORM IS MOTION:

- (41) a. The road runs on for miles and then splits.
b. The path stretches along the shore of the lake.
c. The fence dips and rises in parallel with the terrain.

Lakoff and Turner argue that a form is understood in terms of the motion tracing the form.

Here again, their analysis creates a number of problems. First, their analysis does not delve deeply into the nature of the phenomenon: Neither the Event/State distinction nor the subject NP's characters are mentioned. It seems quite

difficult to extend their analysis to account for how an eventive, "motion" verb is related to a stative, "form" verb.

Next, it is questionable whether the motion/extent contrast falls within the realm of metaphor. As Jackendoff & Aaron (1991:325) point out, 'their characterization obscures certain important distinctions and stretches the notion 'metaphor' to a number of cases that should be understood in other terms.' This criticism cannot be neglected by saying that their definition of metaphor is different from ordinary ones, for making use of metaphor in this case is inconsistent within the very theory of Lakoff. Several theoretical mechanisms are available within the theory of Lakoff (Lakoff 1987), metaphor being just one of them. To account for the data in (41), reference is to be made not to metaphor, but to image-schemas, as in Lakoff (1987).

The metaphor-based approach might appear to be adequate to the extent that "the essence of metaphor is understanding and experiencing one kind of thing in terms of another" (Lakoff and Johnson 1980:5). However, the following consideration argues for an approach based on image-schema rather than on metaphor. The motion/extent contrast finds parallels in non-spatial semantic fields, as in (42) and (43).

Temporal

- (42) a. We moved the meeting from Tuesday to Thursday.
b. The conference went from Tuesday to Friday.

Identificational

- (43) a. The coach changed from a handsome young man into a pumpkin.
b. Our clients range from psychiatrists to psychopaths.

(42a) and (43a) are motion sentences, which assert that the mover changed its position on the abstract path in order over time. In contrast, (42b) and (43b) are extent sentences,

where the subject occupies every point of the abstract path.

Crucially, the metaphor-based approach and the image-schema-based approach will lead to different treatments of extent sentences in non-spatial meanings. The image-schema approach builds on the reasonable assumption that motion and extent sentences have distinct but related image-schema structures. The non-spatial uses are therefore obtained by combining the image-schema structures with metaphors, as in Fig.10.¹¹

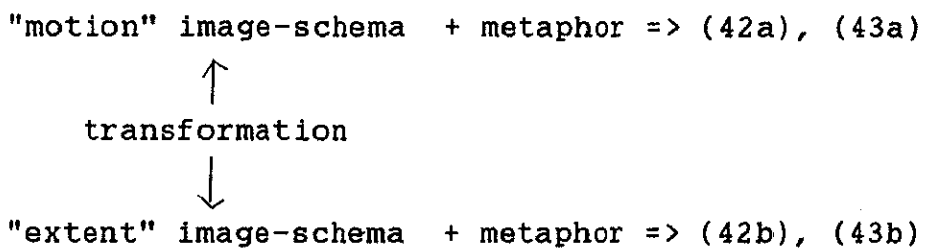

Fig.10

By contrast, the metaphor approach would appear as in Fig.11.

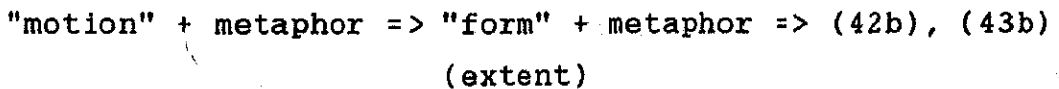

Fig.11

Non-spatial extent sentences would be obtained by applying two metaphors successively to the motion sense. But if we strictly follow the view put forward by Lakoff (1990:54) that "metaphorical mappings preserve the image-schema structure," then the same image-schema structure should persist throughout the two mappings. The image-schema structure preserved in the FORM IS MOTION metaphor should be neutral as to the differences between motion and extent senses. This image-schema structure would also be preserved in the second mapping, so that non-spatial extent senses (42b) and (43b)

would end up with image-schema structures that are neutral as to the motion/extent distinctions. In other words, the metaphor approach would have to say that motion and extent senses have the same image-schema structure, in spite of the fact that the two senses exhibit different topological properties.

Finally, Lakoff and Turner speak of motion vs. form, not motion vs. extent. While a look at (41) may create the impression that either characterization is possible, the contrast should be stated in terms of motion and extent. Bennett (1975:41) observes that the following dialogue is acceptable:

- (44) a. How long is your new tent?
 b. It goes from the back of our garage in the apple tree in the middle of the lawn.

Here go expresses the extent of the tent, not the form.

Of other proposed analyses, then, Langacker's analysis is essentially the same as ours. Lakoff's (1987) analysis has a number of problems, although he is right in resorting to image-schemas. Lakoff and Turner's (1989) metaphor-based approach, besides having a number of shortcomings, is not consistent with the general framework laid out by Lakoff in the first place.

4.3. Further Extensions

4.3.1. Mental Scanning Once Again

In the last section, we have seen that our analysis parallels Langacker's analysis (45) in its essentials.

$$(45) \text{ a. } \left[\begin{array}{c} [[m]l_i]t_i \\ \\ c \end{array} \right]_{T_i} > \left[\begin{array}{c} [[m]l_{i+1}]t_{i+1} \\ \\ c \end{array} \right]_{T_{i+1}}$$

$$b. \begin{bmatrix} [m_1] l_1 \\ \\ C \end{bmatrix} T_1 > \begin{bmatrix} [m_1] l_1 \\ [m_{1+1}] l_{1+1} \\ \\ C \end{bmatrix} T_{1+1}$$

Drawing on this parallellism, we will address the issue of mental scanning in this section.

Langacker maintains that both (45a) and (45b) express motion. While (45a) expresses physical motion by an objectively-construed mover (namely, the subject), (45b) expresses abstract motion by a subjectively-construed mover, specifically the conceptualizer. In other words, (45b) expresses mental movement on the part of the conceptualizer/speaker.

This view seems to be prevalent in the literature. A number of analyses make crucial reference to mental movement and characterize the motion/extent contrast in terms of the contrast between objective movement and subjective (mental) movement.

However, care must be taken before uncritically accepting this view. There seems little doubt that the extent sense involves mental movement on the part of the conceptualizer/speaker. This is perfectly compatible with our analysis, which characterizes the extent sense in terms of a successive transition from one component state to another, as in (46b).

$$(46) a. \begin{bmatrix} A \\ l_1 \\ t_1 \end{bmatrix} => \begin{bmatrix} A \\ l_{1+1} \\ t_{1+1} \end{bmatrix} \quad b. \begin{bmatrix} H_1 \\ l_1 \end{bmatrix} => \begin{bmatrix} H_{1+1} \\ l_{1+1} \end{bmatrix}$$

In the current context, (46b) can be taken to indicate that the conceptualizer makes mental contact with each component state, and that his conception shifts from one component state to the next.

However, a problem crops up when we turn to the motion sense. Notice that (46a) also expresses a successive transition from one component state to another. If the motion sense involves objective movement alone, as widely believed, then the transition in (46a) should be objective movement by the subject, independent of the conceptualizer. This is tantamount to claiming that the conceptualizer makes no mental contact with each component state in (46a).

The absurdity of this claim is well documented by Honda (1992). Honda rightly challenges the assumption that the motion sense involves objective movement alone by commenting on (47).¹²

- (47) a. The hiker went/ran/climbed up the hill.
- b. The new highway goes/runs/climbs from the valley floor to the senator's mountain lodge.

(Langacker 1990:19)

Honda argues as follows (with example numbers changed):

It is true that (47b) involves an upward movement of the conceptualizer/speaker. Otherwise, the conceptualizer/speaker could not identify the location of the highway. However, exactly the same sort of movement is involved in (47a), too. Without an upward mental movement on the part of the conceptualizer/speaker, the hiker would soon go out of his/her perceptual field, rendering it impossible to categorize the entire movement in question as going/running/climbing up the hill.

In other words, the movement expressed by (47a) is also a mental movement on the part of the conceptualizer. The motion/extent contrast cannot be reduced to the presence/absence of mental scanning, which is operative in both senses. The real difference between motion and extent senses

is that the extent sense involves mental scanning alone, while in the motion sense there is actual movement by the mover in addition to the conceptualizer's mental movement.

4.3.2. Enriching the Path

As pointed out in 4.2.2, the subject of the extent sentence may be other than one-dimensional. These extent sentences pose a challenging problem to previous analyses, which have tended to center around extent sentences with a one-dimensional subject. But our analysis can give a coherent account of these sentences.

4.3.2.1. Spread

The verb spread can display an extent sense in which the subject denotes a plane rather than a line.

- (48) a. The city spreads for miles to the north.
b. At the foot of the mountain the city spread out to the bay.

In order to accommodate (48), we must determine how to describe the verb spread. In this connection, Lakoff (1987) makes an intriguing observation, which is originally due to Lindner (1982). Lakoff observes that in (49) out takes a reflexive trajectory, which means that the trajectories of an object's subparts are calculated relative to other subparts.

- (49) The syrup spread out.

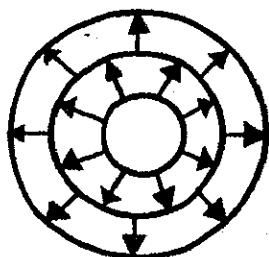

Fig. 12

Here the syrup, or at least part of it, is moving "out" relative to its own prior boundary.

Thus spread can be regarded as incorporating a reflexive trajectory as its path constituent. We tentatively posit the following representation for (49).

(50) [GO([SYRUP],[2D-OUTWARD([SYRUP])))]

SYRUP appears both as a Theme and as a reference object. 2D-OUTWARD is meant for a two-dimensional outward path. In a parallel fashion, (48a) will be represented as in (51).

(51) The city spreads for miles to the north.

[GO_{EXT} ([CITY], [2D-OUTWARD([CITY])])
[TO NORTH]]

The details of the motion expressed by (50) are spelled out as follows. A circle is defined as the set of all points that lie in a given plane, and whose distance from a fixed point O (= center of the circle) in the plane is a given positive number r (= radius). Let S stand for all points on the bounding edge (circumference). Then S is at r_m at the moment t_m . As a consequence, S proceeds on the path which is a linearly ordered set of points $\langle r_0, \dots, r_n \rangle$ concurrent with a sequence of moments $\langle m_0, \dots, m_n \rangle$.

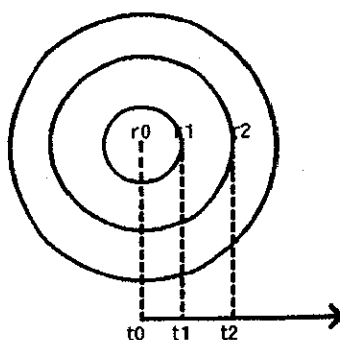

Fig. 13

Now the motion sense of spread is characterized as in (52a). The extent counterpart will be as in (52b).

$$(52) \text{ a. } \begin{bmatrix} S \\ r_m \\ t_m \end{bmatrix} \Rightarrow \begin{bmatrix} S \\ r_{m+1} \\ t_{m+1} \end{bmatrix} \quad \text{b. } \begin{bmatrix} S_m \\ r_m \end{bmatrix} \Rightarrow \begin{bmatrix} S_{m+1} \\ r_{m+1} \end{bmatrix}$$

In this way we can handle the extent sense of spread parallel to that of go without proliferating functions. This treatment is compatible with our characterization of GO and GO_{Ext} in Section 1, which may be summarized as in (53).

- (53) a. [GO([X],[Y])]: X occupies Y by changing X's location in order over time
 b. [GO_{Ext}([X],[Y])]: X occupies Y by changing X_n's location

(53) says merely that the first argument (X) occupies the Path (Y) in both cases, and nothing precludes the two functions from expressing a two-dimensional movement. Whether the subject is a line or a plane is correctly attributed to the difference in Path.

4.3.2.2. Widen, Narrow

The following extent sentences also have subjects that are not one-dimensional.

- (54) a. The road widens here.
 b. The road narrows here.

(54a) and (54b) express the configurations in Fig.14.

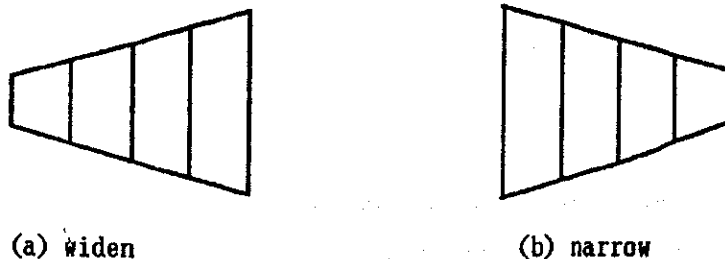

Fig. 14

At first glance it seems quite difficult to handle these complex configurations. But this difficulty disappears once we realize that widen is a deadjectival verb. That is, widen is an inchoative verb related to wide. We thus represent widen and narrow as in (55) by appealing to an Identificational Path.

- (55) a. [GO_{Ident} ([X],[TO_{Ident} ([Property WIDE])])]

b. [GO_{Ident} ([X],[TO_{Ident} ([Property NARROW])])]

In the Identificational field, properties are locations. Let w_m stand for a location on the Identificational Path having to do with width of an object. Then being located at w_m means having the width of w_m , and moving on this abstract Path means change in the subject's width. Thus the motion and extent senses of widen are described as in Fig.15 (a) and (b), respectively.

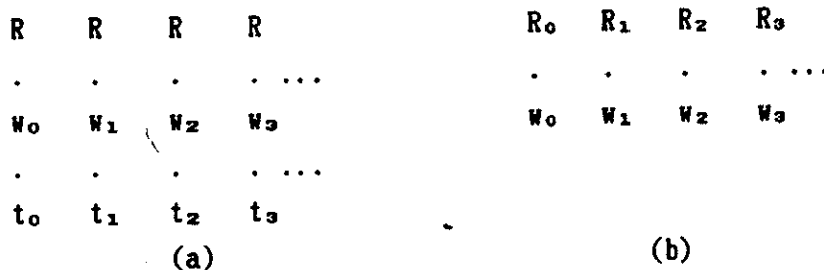

Fig. 15

Accordingly, the extent senses of widen and narrow are characterized as in (56).

- (56) a. $\begin{bmatrix} R_m \\ w_m \end{bmatrix} \Rightarrow \begin{bmatrix} R_{m+1} \\ w_{m+1} \end{bmatrix}$ where $w_m < w_{m+1}$ widen

b. $\begin{bmatrix} R_m \\ w_m \end{bmatrix} \Rightarrow \begin{bmatrix} R_{m+1} \\ w_{m+1} \end{bmatrix}$ where $w_m > w_{m+1}$ narrow

(56a) and (56b) are the same except for one point: Whereas widen means that the width progressively becomes larger, just

the opposite holds with narrow. Hence the different qualifications ($W_m < W_{m+1}$, $W_m > W_{m+1}$).

In this way, our analysis accommodates extent sentences with two-dimensional subjects parallel to those with one-dimensional subjects.

4.4. Conclusion

GO and GO_{Ext} are distinct but share a great deal of internal structure, as envisaged at the beginning of our discussion. Both functions express a successive transition from one component state to another. They differ in (a) whether the transition proceeds with or without the passage of time, and (b) whether the mover is identical throughout the transition.

Our analysis based on semantic functions comes closer to an overall characterization of the motion/extent contrast than the image-schema-based approach or the metaphor-based approach, and can be easily extended to account for extent sentences that have not commanded attention in the literature.

Notes to Chapter 4

* Earlier versions of this chapter were presented at the 12th Cognitive Linguistics Colloquium held at the University of Electro-Communications, April 1992, and at the 8th Kansai Cognitive Linguistics Colloquium held at Osaka University, October 1992. I'd like to thank the audience for comments and suggestions. I'd also like to express my gratitude to Lynne Roecklein, who suggested extensive stylistic improvements.

1. Jackendoff (1990) uses EXT([X],[Y]) instead of GO_{Ext}([X],[Y]), which suggests that he is inclined to the second possibility. But he does not give any justification for his move.

2. In order to underscore the transition expressed by both functions, we may go one step further and neutralize this

difference. In (13a), the mover, A(my), is not subscripted because although Amy cannot exist at two different spatio-temporal locations, it is possible to distinguish Amy at $\langle l_1, t_1 \rangle$ from Amy at $\langle l_{1+1}, t_{1+1} \rangle$ by assuming that the two Amy's are different spatio-temporal manifestations of an individual. Then $\langle A, l_1, t_1 \rangle$ will be rewritten as $\langle A_1, l_1, t_1 \rangle$.

$$(i) \text{ a. } \begin{bmatrix} A_m \\ l_m \\ t_m \end{bmatrix} \Rightarrow \begin{bmatrix} A_{m+1} \\ l_{m+1} \\ t_{m+1} \end{bmatrix} \qquad \text{b. } \begin{bmatrix} H_m \\ l_m \end{bmatrix} \Rightarrow \begin{bmatrix} H_{m+1} \\ l_{m+1} \end{bmatrix}$$

If we choose to add the temporal path to the transition of GO_{Ext} , then (ib) will be rewritten as (ii):

$$(ii) \begin{bmatrix} H_m \\ l_m \\ t_m \end{bmatrix} \Rightarrow \begin{bmatrix} H_{m+1} \\ l_{m+1} \\ t_m \end{bmatrix}$$

3. Jackendoff (1976:139) recognizes this point.

they [=GO_{Ext} functions] do not make essential reference to the passage of time. It is because of this that they, ..., do not describe events, but states of affairs.

4. At first I thought the different characters of the subjects could be reduced to the presence vs. absence of the passage of time. But total reduction seems to be unsuccessful. Now I maintain only that the subjects' characters co-occur with the presence vs. absence of the passage of time.

5. The notations in Jackendoff (1976) are slightly different from those in Jackendoff (1983). GO_{Trans} means the same as GO.

6. To be precise, (20) is an instance of CAUSE-GO, not one of GO.

$$(i) [CAUSE([WE], [GO_{Temp}([MEETING], \begin{bmatrix} FROM([TUESDAY]) \\ TO([THURSDAY]) \end{bmatrix}])))]$$

(Jackendoff 1983:190)

7. Langacker analyzes the contrast in (22) in terms of the difference in the scope of predication.

8. The term "viewer-in-motion" might not be fully appro-

priate. In the following example, a stationary observer reports on what a viewer (=driver) experiences.

- (i) The street was slick with the night's first rain, and Robert McCabe was driving too fast. When the road curved right, his car skidded left and slammed into a pole. (Readers' Digest 1993. Apr. p.29)

9. By contrast, Lakoff is justified in linking path and end of path schemas by means of a transformation, for the two schemas are distinct from each other.

- (i) a. Mary walked over the hill. (path)
- b. Mary lives over the hill. (end of path)

10. Lakoff himself is aware that the 1DTR schema may come from a more fundamental schema.

- (i) a. There are guards posted along the road. (MX)
- b. There is a fence along the road. (1DTR)

Lakoff analyzes this pair as a special case of the multiplex-mass transformation in which the multiplex entity is a sequence of points and the mass is a one-dimensional trajector. The multiplex-mass transformation is originally intended to cover sentences like (ii).

- (ii) a. All men are mortal. (MX)
- b. All gold is yellow. (MS)

Multiplex <-> Mass : As one moves further away, a group of individuals at a certain point begins to be seen as a mass. Similarly, a sequence of points is seen as a continuous line when viewed from a distance.

(Lakoff 1987:441-42)

11. The metaphors linking image-schemas to the Temporal and Identificational senses may be phrased as TIME IS A LOCATION and PROPERTIES ARE LOCATIONS, respectively.

12. I am grateful to Eijiro Tsuboi for bringing Honda (1992) to my attention.

PART III
S-Network

Chapter 5
Metaphor and Thematic Relations*

5.0. Introduction

In chapter 1, I characterized S-links as domain shifts and argued that metaphor and thematic relations fall into the realm of the S-network. In this chapter I will closely examine the two notions, which are similar but not the same.

5.1. Characteristics of Metaphor and Thematic Relations

5.1.1. Metaphor

Lakoff and Johnson (1980) argue that metaphor is not just a matter of words but one of conceptual system. Metaphors as linguistic expressions are possible precisely because there are metaphors in our conceptual system. Metaphor in this conception (Lakoff and Johnson (1980), Lakoff (1987), Lakoff and Turner (1989), etc.) has several characteristics. The first is the systematicity in linguistic correspondences. Sentences in (1) are instances of the THEORIES ARE BUILDINGS metaphor.

- (1) Is that the foundation for your theory?
Quantum theory needs more support.
You'll never construct a strong theory on those
assumptions. (Lakoff and Johnson 1980:46)

Entities in the domain of a theory systematically correspond to entities in the domain of a building. Hence words like foundation or support, which are originally used to talk about buildings, convey the meanings related to theories as well.

Next, the conceptual basis of metaphor makes it possible to understand novel extensions in terms of conventional metaphors. Sentences in (2) are instances of "figurative" or "imaginative" language.

(2) His theories are Bauhaus in their pseudofunctional simplicity.

He prefers massive Gothic theories covered with gargoyles. (Ibid.:53)

We can understand these sentences instantly because they are also instances of the general metaphor THEORIES ARE BUILDINGS.

Third, conceptual metaphor allows us to achieve a polysemy generalization. In (3) expressions like crossroads or spinning one's wheels, which are about a journey, can be readily understood as being about love.

(3) We're at a crossroads.

We're spinning our wheels.

The relationship isn't going anywhere.

(Lakoff 1990:47)

We can say that the two meanings are related via the LOVE IS A JOURNEY metaphor, rather than that these expressions are homonyms.

Fourth, metaphor accounts for the nature of some diachronic semantic change. In English (and many other Indo-European languages as well) there is a tendency for verbs of vision to have developed out of verbs of touching/manipulation. This tendency is explained by means of the VISION IS PHYSICAL TOUCHING/MANIPULATION metaphor.

(4) behold, catch sight of

perceive < Lat. -cipio "seize"

scrutinize < Lat. scrutari "pick through trash"

examine < Lat. ex + agmen- "pull out from a row"

discern < Lat. dis-cerno "separate"

(Sweetser 1990:32)

Metaphor in the sense of Lakoff has these characteristics. Lakoff (1987) further proposes the following:¹

The Spatialization of Form Hypothesis: Conceptual structure is understood in terms of image schemas plus a metaphorical mapping. (Lakoff 1987:283)

5.1.2. Thematic Relations

Jackendoff (1983) formalizes Gruber's (1976) insight that the semantics of motion and location provide the key to a wide range of further semantic fields, as follows:

Thematic Relations Hypothesis

In any semantic field of [EVENTS] and [STATES], the principal event-, state-, path-, and place-functions are a subset of those used for the analysis of spatial location and motion. Fields differ in only three possible ways:

- a. what sorts of entities may appear as theme;
- b. what sorts of entities may appear as reference objects;
- c. what kind of relation assumes the role played by location in the field of spatial expressions.

(Jackendoff 1983:188)

This hypothesis claims that abstract concepts are formed by applying semantic functions like GO, BE, STAY etc. to various semantic fields (e.g. Spatial, Temporal, Possessional, Identificational, etc.). Thus the examples in (5) illustrate verbs in the Possessional field, with the subscript POSS identifying the semantic field.

- (5) a. Beth has/possessed/owns the doll.

The doll belongs to Beth.

[state BE_{POSS} ([DOLL],[place AT_{POSS}([BETH])]]]

b. Beth lost the doll.

[event GO_{POSS} ([DOLL],[path FROM_{POSS}([BETH])]]]

c. Amy gave the doll to Beth.

[CAUSE([AMY],[GO_{POSS} ([DOLL],
[FROM_{POSS}([AMY])])])]
[path TO_{POSS}([BETH])]]]

(Jackendoff 1983:192)

This formalization allows us to capture a cross-field lexical generalization. Many verbs and prepositions appear in more than one semantic field.

(6) a. The coach turned into a driveway.

b. The coach turned into a pumpkin.

(7) a. The train went to Texas.

b. The inheritance went to Philip.

(8) a. Bill kept the book on the shelf.

b. Bill kept the book.

Turn into is spatial in (6a) but identificational in (6b); go is spatial in (7a) but possessional in (7b); keep is spatial in (8a) but possessional in (8b).

These different senses can be unified by keeping the semantic function intact, with different field modifiers being attached. Thus the sentences in (6) are represented as in (9).

(9) a. [GO_{POSIT} ([COACH],[TO([IN([DRIVEWAY])])])]]]

b. [GO_{IDENT} ([COACH],[TO([IN([PUMPKIN])])])]]]

These conceptual structures make explicit the parallelism between the sense of physical motion and that of change in identity.

5.2. Differences between Metaphor and Thematic Relations

5.2.1. Are Thematic Relations Metaphors?

As shown in the last section, metaphor and thematic relations are similar, particularly in that both of them explain polysemy. Thus it may be tempting to regard thematic relations as a subspecies of metaphor. If this is the case, then the theory of thematic relations is simply a notational variant of a portion of the theory of metaphor. In fact, thematic relations can be rephrased by means of metaphors: Time is location, being possessed is a location, properties are locations, events are locations, etc. Thus nothing prevents us from calling thematic relations metaphors, at least in so far as metaphor is characterized in a maximally general way as "understanding one kind of thing in terms of another" (Lakoff and Johnson (1980)).

Distributional facts seem to confirm this view as well. As Lakoff and Brugman (1986) observe, a metaphorical mapping is characterized by its inherent asymmetry between source and target domains.

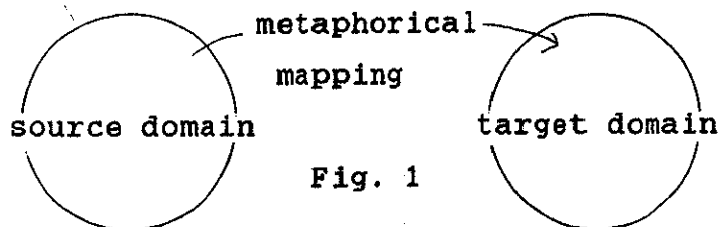

While some of the elements in the source domain may lack corresponding elements in the target domain, the reverse does not hold.

Thematic parallels exhibit this asymmetry: Not all spatial concepts have their counterparts in non-spatial domains. For instance, some of the spatial prepositions may express temporal meanings (e.g. at three o'clock, in two hours, etc.) but not all (e.g. behind, in front of, etc.). As Jackendoff admits in his statement of the Thematic Relations

Hypothesis above, semantic functions available for non-spatial fields are a subset of those used for spatial concepts. The asymmetry between spatial and non-spatial concepts appears to be evidence for treating thematic relations as metaphors.

5.2.2. Abstract Organizing System

Jackendoff, however, has consistently argued otherwise. Jackendoff (1983: 209) mentions, and then rejects, the possibility that thematic relations are nothing more than metaphors, saying that this view debases both the theory of thematic relations and the concept of metaphor. He maintains:

I am inclined to think of thematic structure not as spatial metaphor but as an abstract organization that can be applied with suitable specialization to any field. (Jackendoff 1983:210)

This indicates that semantic functions like GO are independent of any semantic field, including the Spatial one, and never appear alone as concepts. Thus the Thematic Relations Hypothesis is described as in Fig. 2.

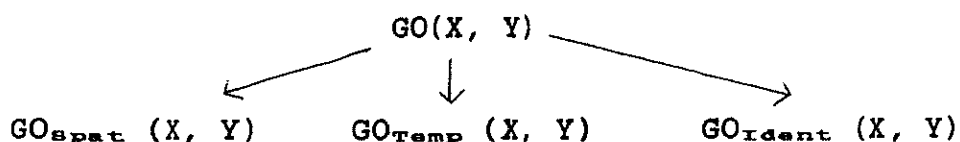

Fig. 2

Abstract concepts are formed by applying GO to non-spatial semantic fields, not by extending the concept of physical motion, which itself is obtained through the application of GO to the Spatial field.

5.2.3. Traugott (1985)

Following Jackendoff (1983), Traugott claims that thematic relations and metaphor need to be distinguished. Among the arguments which she presents, the most convincing one is that the lexicons of verbs expressing thematic relations are not all locative in origin.

- (10) have < IE kap- "grasp"
 possess < Lat. possidere < posse "be able" +
sedere "sit"
 belong < OE be- "thoroughly" + longian "suit"
 receive < Lat. capere "take, grasp"
 lose < IE leu- "untie, loosen"

Note the clear contrast between (10) and the thematic relations illustrated in (5).

Metaphor in the sense of Lakoff and Johnson (1980) divides into surface expressions as linguistic metaphor and conceptual schemata underlying those expressions as conceptual metaphor. Traugott maintains that thematic relations are to be located at a higher, "ontological" level. This is summarized as in Table 1.

	Lakoff & Johnson	Jackendoff
"ontological" level		thematic relations
conceptual schemata	conceptual metaphor	
surface expression	linguistic metaphor	

Table 1

5.2.4. Jackendoff & Aaron (1991)

Jackendoff and Aaron use linguistic tests to show the difference between thematic relations and metaphor, on the

assumption that metaphor as standardly understood is characterized both by a mapping between domains and by a sense of incongruity. For instance, (11) is a realization of the conceptual metaphor A RELATIONSHIP IS A JOURNEY.

(11) Our relationship is at a dead end.

(12) is the diagnostic sentence of (11).

(12) Of course, relationships are not journeys — but if they were, you might say ours is at a dead end.

This sentence is an overt explication of the metaphorical interpretation of the sentence in (11): the first clause acknowledges the incongruity of the metaphorical mapping, and the second constructs a hypothetical invocation of the mapping that motivates the metaphorical reading.

Now (13a) and (13b) are metaphors corresponding to the thematic relations constituting the Circumstantial field.

(13) a. PURPOSES ARE DESTINATIONS b. STATES ARE LOCATIONS

When the above diagnostic is applied to (13), the resulting sentences sound odd.

(14) a. !Of course, purposes aren't destinations — but if they were, you might say we haven't reached our goal of finishing this review article.

b. !Of course, states aren't locations — but if they were, you might say I've gotten through my depression.

Here the congruity is acknowledged, but its invocation seems beside the point.

The same is true of other semantic fields. Sentences in

(15) and (16) are about Temporal and Existential fields, respectively.

(15) a. !Of course, times aren't locations — but if they were, you might say we're getting close to Christmas.

b. !Of course, time is not a medium in motion — but if it were, you might say the year passed by quickly.

(16) !Of course, existence isn't a place — but if it were, you might say that a new idea has come into existence/*it.

Based on these observations, Jackendoff and Aaron argue that there is an important division between metaphors that are based on mapping of incongruous domains and those that are based on thematic parallelism.

This does not mean that they are totally unrelated, however. Jackendoff and Aaron go on to say that thematic parallels may be exploited to form specialized mappings. Thus the metaphor LIFE IS A JOURNEY may be seen as a more specialized case of the thematic parallel between location and Circumstance. LIFE IS A JOURNEY in turn serves as the basis for subcases such as DIFFICULTIES IN LIFE ARE IMPEDIMENTS TO TRAVEL, PROGRESS IS THE DISTANCE TRAVELED, and DEATH IS THE END OF LIFE'S JOURNEY. The relationships between metaphors and the thematic relation are described as in Fig. 3.

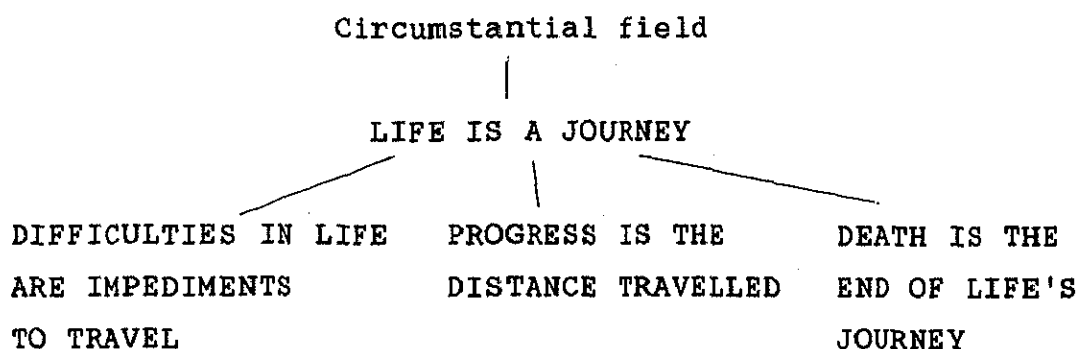

Fig. 3

5.2.5. Jackendoff (1992)

Jackendoff (1992) distinguishes the theory of thematic relations from that of metaphor in terms of concept formation. According to the theory of metaphor, abstract concepts are constructed by a process of metaphor from a basis of concrete perceptual concepts. Jackendoff points out a flaw in this view using possessional concepts. The underlined words in the possessional expressions in (17) also appear in sentences about spatial motion in (18), thus instantiating the spatial-possessional parallelism.

- (17) a. Bill gave a book to Harry.
 Harry donated the book to the library.
- b. Harry received/got a book from Bill.
- c. The book was a present/gift from Bill to Harry.
- d. Harry gave the book back to Bill.
 Bill got the book back from Harry.
- e. Bill gave the book away.
- (18) a. Bill went to the store.
 Bill threw the ball to Harry.
- b. Harry came from the store.
 Bill brought a newspaper from the store.
- c. We were on a train from Boston to Philadelphia.
- d. Then we went back to Boston.
 We came back from Philadelphia.

e. Bill pushed the food away.

To say that this parallelism is induced by a metaphorical mapping entails that children first learn spatial concepts and then become capable of constructing possessional concepts from spatial ones. Thus at a certain developmental stage children understand spatial concepts but not possessional concepts.

But note that at this stage spatial concepts are the only concepts available for children. How can children begin to construct possessional concepts, even the existence of which is beyond their understanding? There is no way to achieve the concept of possession, which cannot be constructed from any combination of spatial concepts.

Jackendoff further points out that the parallels between physical space and possession are very limited.

Physical space is of course 3-dimensional, so an object can move up, down, frontward, backward, and sideways. By contrast, the possessional parallel has no dimensions: one can't give something upward or frontward. Physical space is continuous: if something moves from point A to point B, it occupies all the intermediate positions between A and B along the way. By contrast, the possessional parallel is discontinuous: there are no intermediate positions that an object traverses between being owned by X and being owned by Y. One can move a book toward or even partway toward Bill; but one cannot give a book toward, much less partway toward, Bill.

(Jackendoff 1992:64)

Neither the emergence of possessional concepts nor the non-parallels between physical space and possession can be accounted for simply by saying that possessional concepts are extensions of spatial ones.

Jackendoff suggests that the parallelism between spatial and possessional concepts is the result of three independent factors, which is what the Thematic Relations Hypothesis claims: (1) the notion of physical space and of objects being located in it; (2) the notion of possession; and (3) an innate abstract organizing system. This theory is schematically compared with the theory of spatial extension as in Fig. 4.

Piaget/Lakoff

spatial concepts -> possessional concepts

Thematic Relations Hypothesis

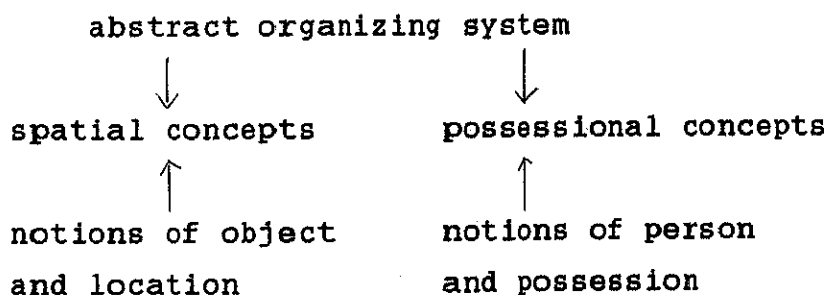

Fig. 4

(Jackendoff maintains that Lakoff's view is very similar to Piaget's and combines them into one. But this does not mean that Lakoff identifies himself as following Piaget. Nor is the claim that abstract concepts are formed out of concrete ones essential to Lakoff's theory, as will be clear later.)

In short, although at first sight it looks as if children are learning by a process of metaphorical extension, this is not actually the case. Children have notions of possession as well as those of object and location among the innate stock of primitives, and by applying them to the abstract organizing system construct possessional and spatial concepts. Children would not expect a full parallelism because physical space and possessional space are different.

5.3. Metaphor as a Set of Correspondences

5.3.1. Thematic Relations as Distinct from Metaphor

The last section has given us a better understanding of thematic relations: Thematic relations belong to the abstract organizing system, independent of any semantic domain, including the Spatial one. Cross-domain asymmetries, which at first sight might appear to be due to metaphorical mappings, are in fact induced by domain-specific properties.

Jackendoff's theory has been consistent with this understanding throughout. Anderson's (1987:115) identification of the theory of thematic relations as a weak version of the localist hypothesis, rather than a strong version that aims to reduce all case relations to spatial ones, is quite understandable. To claim that all abstract concepts are extensions of spatial concepts inevitably commits one to the strong version, but the theory of thematic relations holds the Spatial domain to be only one of the several domains. That not all abstract concepts are reduced to spatial concepts is rather to be expected.

By now the distinction between thematic relations and metaphor is clear as well. To the extent that metaphor is defined as "understanding one thing in terms of another" (Lakoff and Johnson 1980), thematic relations can be said to be metaphors. Still, thematic relations need to be distinguished from other metaphors, as amply demonstrated by considerations in terms of historical developments (Traugott 1985), incongruity (Jackendoff and Aaron 1991), and concept learning (Jackendoff 1992).²

Particularly noteworthy is Jackendoff's (1992) claim that abstract concepts are not constructed by metaphorical mappings per se. His argument that even abstract concepts need innate basis is convincing. The theory of metaphor seems to be mistaken so long as it adheres to the view that mappings create abstract concepts.

5.3.2. From Invariance Hypothesis to Invariance Principle

This does not mean that the theory of metaphor is completely mistaken, however, for this view is actually not as essential to the theory of metaphor as might appear at first glance. The view entails that mappings create image-schematic structures in the target domain, and the Invariance Hypothesis (Lakoff 1990) can be certainly read in such a way as to indicate that source domain structures are imparted to the target domain, which itself is not inherently structured.

The Invariance Hypothesis: Metaphorical mappings preserve the cognitive topology (this is, the image-schema structure) of the source domain. (Lakoff 1990:54)

However, Brugman (1990) points out that the Invariance Hypothesis as stated is not explicit enough for us to know "whether such 'structure' exists independent of a mapping or is created by it" (Brugman 1990:262), indicating the lack of consensus even among the circle of cognitive linguistics.

Lakoff (1992) makes explicit his stance and advances the Invariance Principle, a revision of the Invariance Hypothesis.

The Invariance Principle: Metaphorical mappings preserve the cognitive topology (that is, the image-schema structure) of the source domain, in a way consistent with the inherent structure of the target domain. (Lakoff 1992:215)

The phrase at the end of the statement beginning with "in a way ..." clearly indicates that a target domain structure exists prior to a metaphorical mapping. Lakoff goes on to say that the target domain structure plays a central role in determining the preserved properties:³

A corollary of the Invariance Principle is that image-schema structure in the target domain cannot be

violated, and that inherent target domain structure limits the possibilities for mappings automatically.

(Lakoff 1992:216)

Thus image-schematic structures in the target domain are not constructed by a mapping. Both source and target domains have preexisting structures, which are not perfectly identical. But parts of the source domain structure parallel parts of the target domain structure. The parallels count as a set of correspondences in a metaphorical mapping.⁴

The theory of metaphor thus conceived is very similar to the theory of thematic relations in that both claim that domain-specific properties constrain the parallelism. The two theories are not identical, as shown in section 5.2., but they are compatible.

Notes to Chapter 5

* This chapter is an English translation of part of Iwata (1994).

1. Lakoff (1987:283) proposes the following image-schemas: CONTAINER, PART-WHOLE, UP-DOWN, LINK, CENTER-PERIPHERY, FRONT-BACK, and LINEAR SCALE.

2. Interestingly enough, Lakoff and Turner (1989) claim that possessional concepts are independent of metaphor.

In addition, the source domains of many metaphors are typically understood without metaphor. Thus, departures, journeys, plants, fire, sleep, days and nights, heat and cold, possessions, burdens, and locations are not themselves metaphorically understood, at least insofar as they form a basis for the metaphorical understanding of other concepts. (Lakoff and Turner 1989:59)

Lakoff and Turner divide concepts into those which are understood of their own and those which are metaphorically understood, and assign possessional concepts to the former

category. This indicates that possessional concepts exist prior to metaphorical mappings, a claim identical with Jackendoff's and Traugott's.

It is true that Lakoff's theory of metaphor does not delve deeply into the issue of concept formation, but this does not mean that the theory of metaphor contradicts the Thematic Relations Hypothesis. The two theories have a lot in common.

3. Turner (1993) arrives at a similar conclusion.

In metaphoric mapping, for those components of the source and target domains determined to be involved in the mapping, preserve the image-schematic structure of the target, and import as much image-schematic structure from the source as is consistent with that preservation.

(Turner 1993:302-303)

4. See Iwata (1995b) for a reconsideration of metaphorical mappings in this light.

Chapter 6

Thematic Parallels and Non-Parallels*

6.1. Thematic Relations Hypothesis

It has often been noted that many grammatical patterns used to describe physical objects in space also appear in expressions that denote non-spatial domains. Thus the verb *go* may express a change of location as in (1a), a change of possession as in (1b), or a change of property as in (1c).

- (1) a. The bird went from the ground to the tree.
- b. The inheritance went to Philip.
- c. The light went from green to red.

Jackendoff's (1983) Thematic Relations Hypothesis or TRH accounts for the paradigm in (1) by claiming that sentences in (1) are all realizations of the GO-function, based on the assumption that the linguistic parallelism reflects an underlying conceptual parallelism.

the concepts they express are all specialized forms of the general concept [GO(X, P)], which represents the motion of some object X (the theme) along some path P.

(Jackendoff 1987:152)

Consequently, sentences in (1) are represented as in (2), where GO is subscripted with field modifier Spatial, Possessional, or Identificational.

- (2) a. [GO_{spat} ([BIRD],[FROM GROUND TO TREE])]
- b. [GO_{poss} ([INHERITANCE],[TO PHILIP])]
- c. [GO_{ident} ([LIGHT],[FROM GREEN TO RED])]

While the parallelism between spatial and non-spatial concepts seems hardly controversial, there is an important

point which has received relatively little attention in the discussion of the parallelism, namely that it is not a full parallelism. Certainly spatial and non-spatial concepts are not entirely parallel, and one cannot just blithely speak of parallelism. An adequate theory must account for non-parallelisms as well.

As already seen in 5.2.5., Jackendoff (1992:65) accounts for the failure of a full parallelism as follows. Taking up possessional concepts as an example, Jackendoff claims that the parallelism between spatial and possessional concepts is the result of three independent factors: The conception of physical space and of objects being located in it, the notion of possession, and an abstract organizing system. Spatial and possessional concepts are obtained by applying an abstract organizing system to the notion of space and that of possession, respectively, as in Fig. 1.

Piaget/Lakoff

spatial concepts -> possessional concepts

Thematic Relations Hypothesis

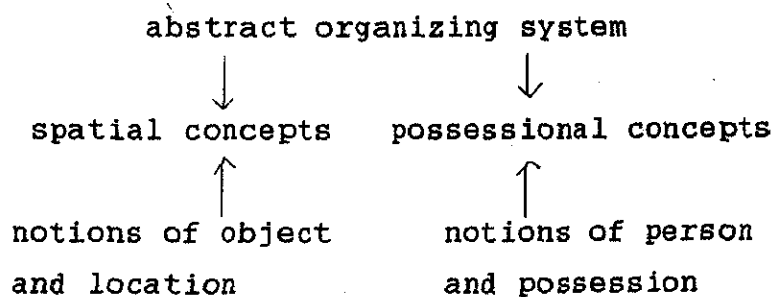

Fig. 1

Possessional concepts are partially parallel to spatial concepts, but not entirely so,

because the notion of location in physical space ranges over three continuous orthogonal degrees of freedom, whereas what we might call "possessional space" ranges

over the discontinuous unstructured set of individuals.

(Jackendoff 1992:65)

That is, each semantic field has its own particular properties, thereby preventing a full parallelism.¹

All this suggests the need to recognize the factor of field-specific properties. Although this factor tends to be left out of the discussion, it constitutes an essential part of the thematic parallels. Even the different uses of the verb go, stock examples of thematic parallelism, are obtained as shown in Fig. 2.

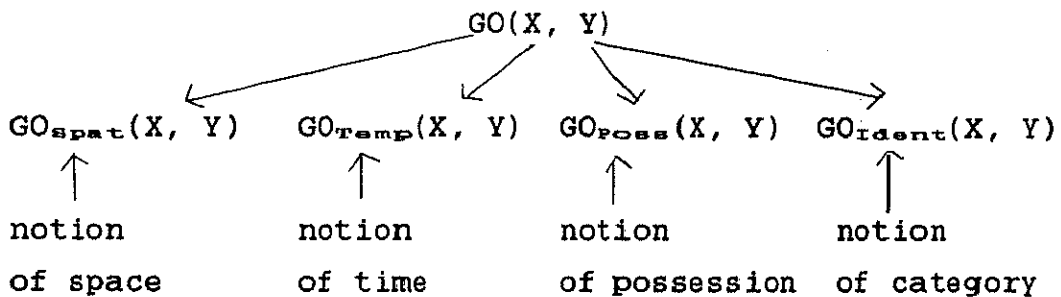

Fig. 2

Given that field-specific properties constrain the parallelism, then, the primary object of study is each semantic field, rather than the parallelism. In what follows, I will examine how three semantic fields (Temporal, Possessional, and Identificational) are structured, and show that field-specific properties account for both thematic parallels and non-parallels.

6.2. Non-spatial Semantic Fields

6.2.1. Temporal

I begin by reviewing two pertinent observations Clark (1973:49) makes about time. First, time is one-dimensional. Thus time ought to be described using one-dimensional spatial terms. Adjectives like long-short and far-near are therefore

appropriate and are certainly used in temporal expressions.

(3) Time was short. The day has been long.

The end of the world is near. Monday seems so far away.

By contrast, the following adjectives, which do not meet the one-dimensional constraint, do not occur in productive time expressions in English.²

(4) wide-narrow, tall-short, high-low, deep-shallow

Second, time is asymmetrical or directed. Therefore, time ought to be described with one-dimensional relational prepositions which are also asymmetrical. The front-back prepositions are appropriate, because they do not presuppose more than one dimension in the space they describe, and have the property of being asymmetrical, with front positive and back negative.

(5) before, after, ahead, behind, in front, in back, etc.

Relational terms derived from top-bottom or left-right, which presuppose more than one dimension, are not used to describe time.

Based on these observations, I claim that the temporal field is structured as shown in Fig. 3.

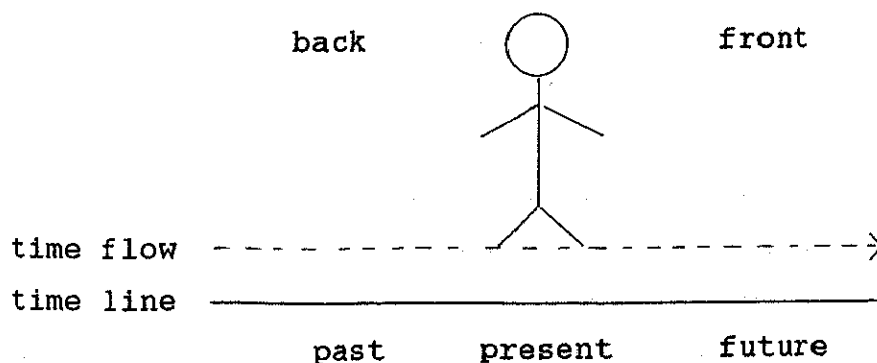

Fig. 3

As noted above, time is a line extending from the past to the future. Yet there is another characteristic of time, viz. that time flows incessantly from the past to the present to the future. We humans are located on the time flow, with our front-back orientation corresponding to the future-past orientation, and are thereby conveyed in the direction of future.³

One apparent problem with Fig. 3 is that it covers only one of the movements available in the temporal field. Clark (1973:50) notes that we humans are seen in one of two ways with respect to the time "highway": either (1) we are moving along it, with future time ahead of us and the past behind us; or (2) the highway is moving past us from front to back. The two metaphors, which are called the moving ego and moving time metaphors, are exemplified in (6) and (7), respectively.

- (6) Trouble lies ahead. The worst of it is behind us.
We are just coming into troubled times. I look forward to Monday. John will be here from Monday on(ward).
- (7) Noon crept up on us. Friday arrived before we knew it. Thursday rushed by. Time flew by.

Fig. 3 depicts time as going only in the direction of future, which is compatible with the moving ego case. But the moving time metaphor apparently describes a movement in the opposite direction, i.e. a pastward movement, totally contradicting Fig. 3. It thus appears that a pastward movement of time ought to be independently specified so as to accommodate the moving time metaphor.⁴

On closer examination, this turns out not to be the case, however: The moving time metaphor in fact does not contradict Fig. 3, and time moves in the direction of future alone. To illustrate, consider the verb approach, which may combine

with either metaphor to yield two movements.

- (8) a. We're approaching Christmas.
- b. Christmas is approaching.

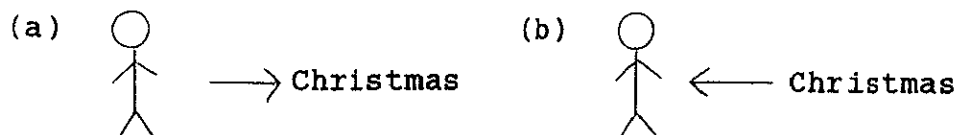

Fig. 4

Now consider spatial movement. When a person moves from one place to another, he can conceive of his journey in two ways: either he travels through a landscape that is stationary relative to his movement, or else he remains conceptually stationary while the landscape travels past him. For instance, suppose I am on the Hikari Super Express bound for Osaka. As the train is coming near Kyoto, I may utter either (9a) or (9b).

- (9) a. We're approaching Kyoto.
- b. Kyoto is approaching.

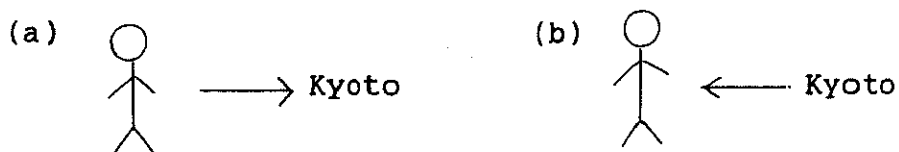

Fig. 5

Objectively, the movement is identical across the two sentences: The train, not Kyoto, is moving. Yet in (9b) Kyoto is conceptualized as moving toward me. This conceptualization is made possible by a shift in perspective (Langacker 1991).

- (10) The telephone poles are rushing past at 60 miles

per hour.

(Langacker 1991:266)

The clear parallelism between (8) and (9) indicates where the moving time metaphor comes from. The two distinctive modes of conceiving spatial movement also apply to time, which is thought of as movement: Time moves futureward, as Fig. 3 indicates, but is construed differently between the two metaphors (i.e. moving ego and moving time).

Thus both of the two metaphors converge on Fig. 3. Moreover, other aspects of time also follow from Fig. 3. If we locate a point on the time line in relation to the ego, the future is in front of the ego, and the past behind the ego.

(11) In the weeks ahead of us ... (future)

That's all behind us now. (past)

(Lakoff and Johnson 1980:41)

If, on the other hand, we assess the relative position of two points on the time line, then the past comes before the future.

(12) In the following weeks ... (future)

In the preceding weeks ... (past)

(Ibid.)

The two conceptualizations can mix with no ill effects.

(13) We're looking ahead to the following weeks.

(Ibid.)

Now there is another essential conceptualization structuring the temporal field, which is illustrated in (14).

(14) a. The meeting is at 6:00.

- b. We moved the meeting from Tuesday to Thursday.
 - c. Despite the weather, we kept the meeting at 6:00.
- (Jackendoff 1983:190)

Jackendoff (1983) argues that sentences in (14) assert the temporal location of an event (and change or lack thereof) parallel to the spatial expressions in (15).

- (15) a. The statue is in the park.
 b. We moved the statue from the park to the zoo.
 c. Despite the weather, we kept the statue on its pedestal. (Ibid.)

The conceptualization might be phrased as EVENTS ARE LOCATED ON A TIME-LINE. Unlike the moving time metaphor or the moving ego metaphor, reference to the ego or to the time flow is not essential. Thus the abstract movement in (14b), i.e. change of scheduling, is described as in Fig. 6.

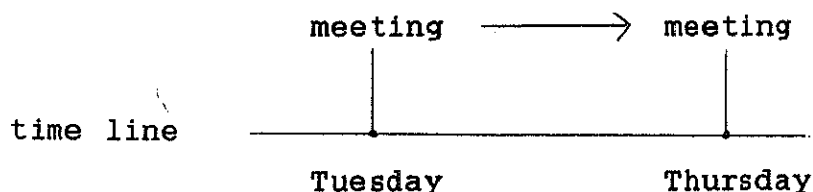

Fig. 6

Closely related to this conceptualization is the following metonymy, which is motivated by a contiguous relationship between an event and its temporal location.

TIMES STAND FOR EVENTS OCCURRING AT THOSE TIMES

- (16) a. Last night was fun.
 b. The day before Christmas is crazy.
 c. Monday mornings always go wrong.

(Lakoff 1993:34)

EVENTS ARE LOCATED ON A TIME-LINE can be integrated into Fig. 3 to form a coherent whole. In fact, it may combine with either the moving time metaphor or the moving ego metaphor to create ambiguities in some instances. Miller and Johnson-Laird (1976) point out that (17) may mean either that the date became two days later or two days earlier, depending upon whether you think of yourself as advancing into the future or of time as advancing toward you.

(17) He advanced the date of the meeting by two days.
 (Miller and Johnson-Laird 1976:463)

Lindner (1983) similarly observes that (18) may mean either that the deadline will be postponed or that it will be moved one hour earlier.

(18) Move the deadline up by an hour. (Lindner 1983:141)

The two readings of (17) can be illustrated as follows, where t_1 stands for an originally scheduled time, and t_2 a newly set time.

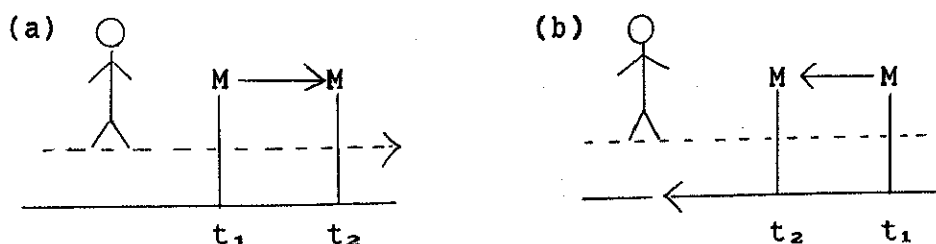

Fig. 7

In (a), the ego is moving along the time line (landscape) that is stationary, and is thus advancing in the direction of future. In contrast, in (b) the direction is reversed by a perspective shift. The ego (or the time flow) is conceptualized as stationary, while the time line (landscape) passes him.⁵

One final word about the movement in the temporal field. I have distinguished the time flow from the static time line, and claimed that the ego is conveyed on the time flow. Thus despite the term 'moving ego metaphor', it is time, not the ego, that actually moves. The ego is, so to speak, in the vehicle of time. As the vehicle moves, the ego may well be said to move as well. But the ego himself cannot move at his will, as in the spatial movement. (19) is not acceptable, except in a scientific fiction setting like Back to the Future.⁶

(19) *John went from Tuesday to Wednesday.

6.2.2. Possessional

Let us now turn to the possessional field, whose representative examples are the following:

- (20) a. Beth has/possesses/owns the doll.
The doll belongs to Beth.
b. Beth received the doll.
c. Beth lost the doll.
d. Amy gave the doll to Beth.
e. Amy sold the doll to Beth for \$5.
f. Beth bought the doll from Amy for \$5.

(Jackendoff 1983:192-93)

Being possessed is conceptualized as abstract location, and change of ownership as change of abstract location. The parallelism between change of ownership and spatial motion is clearly seen in the prepositions used: The object of from is associated with the initial state of the change (20f), while that of to with the final state of the change (20d, e). Thus the paths in the possessional field consist in the transfer of goods as well as the transfer of money (cf. Fillmore 1977).

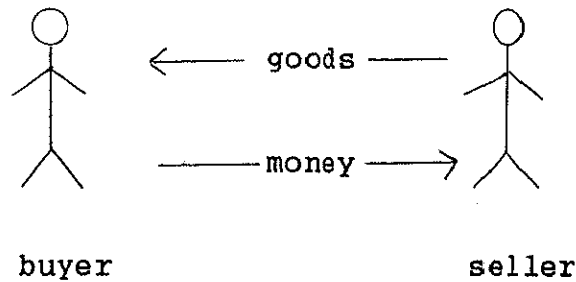

Fig. 8

As Jackendoff (1992) points out, the possessional path has a distinctive character, in that its dimensionality is entirely different from that of physical space.

Physical space is of course 3-dimensional, so an object can move up, down, frontward, backward, and sideways. By contrast, the possessional parallel has no dimensions: one can't give something upward or frontward.

(Jackendoff 1992:64)

Also, the possessional path is discontinuous.

Physical space is continuous: if something moves from point A to point B, it occupies all the intermediate positions between A and B along the way. By contrast, the possessional parallel is discontinuous: there are no intermediate positions that an object traverses between being owned by X and being owned by Y. One can move a book toward or even partway toward Bill; but one cannot give a book toward, much less partway toward, Bill.

(Ibid.)

Thus the possessional paths degenerate essentially into their endpoints, i.e. participants of the transaction. Consequently, only a very limited range of spatial terms like from or to can be used to describe "possessional space".

In Fig. 8, participants are described as point-like

entities without any extension whatsoever, and hence no bounded area seems discernible. Yet sometimes out occurs as in the following verb-particle combinations.

- (21) a. Did you lend out all your books?
b. He bought a bunch of trucks and rented them out.
(Lindner 1983:78)

Lindner (1983:79) observes that the transfer of ownership is codable by out in (21) because:

possession is construed as an abstract neighborhood around a person, a sort of sphere of influence, such that items owned are IN it and items transferred to someone else are out.

POSSESSION NEIGHBORHOOD

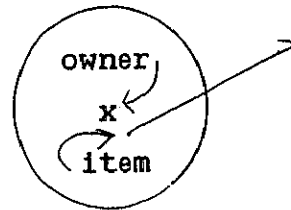

Fig. 9

Consequently, possessional location in Fig. 8 is to be taken as having some extension.

6.2.3. Identificational

Finally, let us consider the Identificational field, which concerns categorization and ascription of properties.

(22) gives examples of verbs in this field.

- (22) a. Elise is a pianist.
b. Elise became/turned into a mother.
c. The coach changed from a handsome young man into a pumpkin.

The basic conceptualization may be phrased as PROPERTIES ARE LOCATIONS: Being a member of a category or having a

property plays the role of location, and change of property is change of abstract location. Thus (22c) can be illustrated as in Fig. 10.

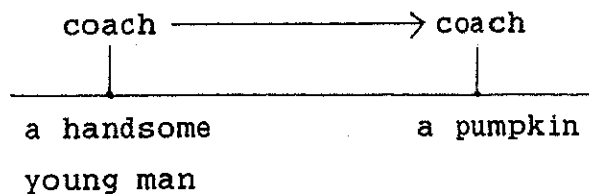

Fig. 10

The object of from is associated with the initial state of the change (i.e. being a handsome young man), and the object of into with the final state of the change (i.e. being a pumpkin). It seems that identificational space is just one-dimensional, and admits of neither two- nor three-dimensional expressions.

Another thing to be noted is that a location on the identificational path is not strictly a point, and may have some width. The preposition into in (22 c) suggests that the final state of the change is conceptualized as a bounded area. That change of state is expressed either in terms of going into, or coming out of, a bounded area is compatible with another conceptualization concerning categorization, viz. CLASSICAL CATEGORIES ARE CONTAINERS (Lakoff 1990). Thus part of (22c) can be described as in Fig. 11, where the coach went into a bounded area of the category pumpkin.

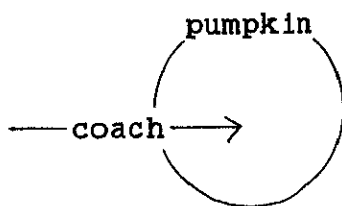

Fig. 11

6.2.4. Motion and Path

Having seen how the non-spatial semantic fields are structured, we are now in a position to see clearly what are the non-spatial counterparts of motion and space. Let us briefly summarize varieties of motion and space.

6.2.4.1. Varieties of Motion

In the Temporal field, time is conceptualized as moving. Yet there is another thing that can be moved, i.e. scheduling of activities (e.g. They moved the meeting from Tuesday to Thursday). Consequently, there are two kinds of abstract motion in this field: passage of time and change of scheduling.

In the Possessional field, the transfer of ownership counts as motion, and in the Identificational field, change of properties is change of abstract location.

6.2.4.2. Varieties of Space

Varieties of space are distinguished from each other in terms of three parameters: dimensionality, inherent direction, and continuity.

	Spat	Temp	Poss	Ident
Dimension	3-D	1-D	0-D	1-D
Directed	-	+	-	-
Continuous	+	+	-	+

Table 1

Physical space is three-dimensional. It is not inherently directed. Thus, given two locations A and B, you can go either from A to B or from B to A. And physical space is continuous.

Temporal space is one-dimensional. It is inherently directed in that time flows necessarily from the past to the present to the future. And it is continuous.

Possessional space is unique in that it ranges over the discontinuous unstructured set of individuals. Thus it is

zero-dimensional, and is discontinuous. Transfer of ownership goes from anyone to anyone else, so possessional space is not inherently directed.

Finally, Identificational space is one-dimensional. It is not inherently directed: Nothing seems to limit the direction of change of properties. And it is continuous.

6.3. Case Studies

As just seen, each semantic field has its own particular properties. I claim that when lexical items appear in more than one semantic field, these field-specific properties constrain their meanings, thus resulting in non-parallel properties across fields.

6.3.1. Between and From - To

The prepositional expression that best exemplifies thematic parallelism is perhaps from - to: It appears in all the four fields, apparently keeping its basic meaning intact. Interestingly enough, between, which somewhat resembles from - to, is a good illustration of the role field-specific properties play in establishing cross field parallelism and non-parallelism.

6.3.1.1. Spatial

Between possesses two basic senses as in (23a) and (23b), which will be referred to as location and motion senses, respectively.

- (23) a. Aranjuez is between Madrid and Granada.
b. This train runs between Madrid and Granada.

(Hawkins 1984:169)

In the location sense, the Theme occupies just a portion of the space separating the two points, as schematically represented in Fig. 12 (a). Between in this sense can be

modified by expressions emphasizing an intermediate position between the two points, like somewhere or midway.

- (24) a. The island of Santa Catarina is roughly midway between Sao Paulo and Porto Alegre. (COBUILD)
b. I lost my keys somewhere between the car and the house. (OALD)

Between has another sense as in (25), where the whole path is designated as in Fig. 12 (b).

- (25) distance between the spindle center and the column

As for from - to, the only example I can think of that expresses a static location seems to be the one in (26), where all the intermediate positions are occupied as in Fig. 12 (c).

- (26) This road goes from Denver to Indianapolis.

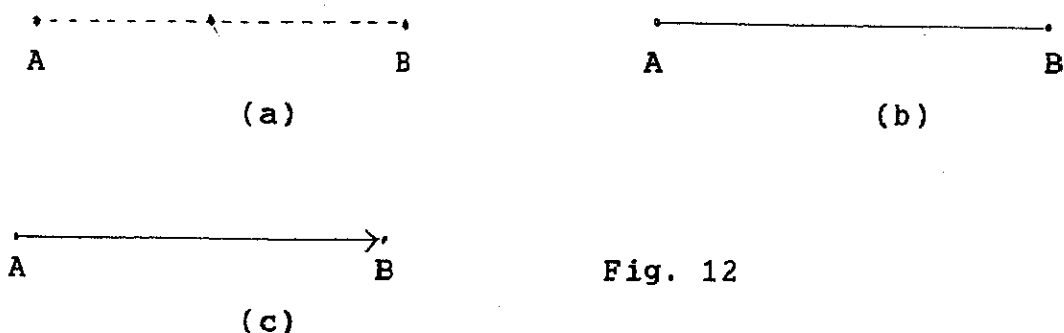

Next let us go on to the motion sense. A good illustration of the difference between from - to and between is found in Hawkins (1984), who observes that unlike from - to, between is not directed, and that (27) contrasts significantly with (28).

- (27) This train runs from Los Angeles to San Diego.

(28) This train runs between Los Angeles and San Diego.

In (27), the train starts its trip in Los Angeles and ends up in San Diego. While this might also be true of (28), a more likely interpretation of (28) is that the train alternately goes from one city to the other.

This contrast becomes even more apparent when the order of the two end points is reversed. While the direction of the train in (29a) is necessarily the opposite of that in (27), this is not a necessary feature of the contrast between (28) and (29b).

- (29) a. This train runs from San Diego to Los Angeles.
b. This train runs between San Diego and Los Angeles. (Hawkins 1984:77-78)

Thus the motion senses of between and from - to are as represented in Fig. 13 (a) and (b), respectively.

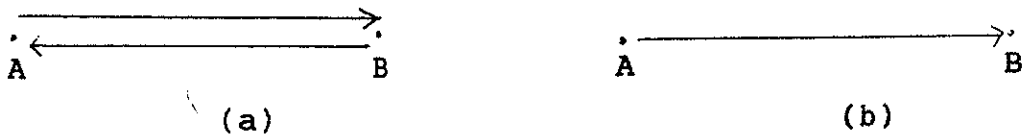

Fig.13

6.3.1.2. Temporal

Temporal space is one-dimensional and continuous, thus matching the location sense of between. Yet there is a difference between Spatial and Temporal uses. As already seen, Temporal space is unique in being inherently directed. Thus although between itself does not carry the sense of direction, the order of the reference objects cannot be freely reversed.

- (30) a. You'll have to go between 9 and 10 tomorrow morning.

- b. *You'll have to go between 10 and 9 tomorrow morning.

Another characteristic of Temporal space is that it is continuous. Therefore, one can refer to an arbitrary intermediate position on the temporal path.

(31) at any hour between two PM and three AM.

(Brown Corpus)

It seems that Temporal between is limited to the location sense. This is probably due to the difficulty with which to think of alternate movements in the Temporal field that correspond to (28).

6.3.1.3. Possessional

Possessional space being discontinuous, the paths reduce to their endpoints. Therefore, the location sense, which designates an intermediate position, is not compatible with, and hence is unavailable in the Possessional field.

The following are the only kinds of examples that seem to exemplify between applied to the Possessional field.

- (32) a. Share the sweets between the children. (COBUILD)
b. The land was divided equally between them.

(COBUILD)

Clearly, this is not the location sense mentioned above. But it is not the possessional counterpart of the motion sense, either. Between in (32) conveys the movement of ownership to endpoints, not the alternate movements of ownership from one person to the other.

The motion sense of from - to likewise expresses the movement of ownership to endpoints, as in Fig. 14 (b).

(33) The fortune went from John to his son.



Fig.14

6.3.1.4. Identificational

Identificational space being one dimensional and continuous, the location sense of between is available. Being at an intermediate position between A and B on the Identificational path means being neither A nor B, but a mixture of both.

(34) a color between green and yellow

(35) She gave a sound that was something between a gasp and a sob. (S. Maugham, Virtue)

Expressions like somewhere that emphasize an intermediate position can be appended to the sentences.

(36) My job is somewhere between a typist and a personal assistant. (OALD)

A number of expressions beside somewhere serve the same purpose.

(37) a middle position between the extremes of scepticism and gullibility (Brown Corpus)

(38) The form of galvanic activity is halfway between the magnetic form and the electrical form.
(Brown Corpus)

(39) ... there are intermediate cases between the poles of pure use and pure mention.

(Sperber and Wilson 1980:305)

The motion sense of between is also available in the Identificational field. The following examples express alternate movements from one property to the other.

- (40) a. He oscillates between conservatism and radicalism.
b. The temperature wavered between freezing and thawing. (COBUILD)
- (41) The weather alternated between rain and sunshine.
(OALD)

Finally, let us touch on from - to. Both location and motion senses are available, exemplified by (42) and (43), respectively.

- (42) a. Our clients range from psychiatrists to psychopaths.
b. This theory ranges from the sublime to the ridiculous. (Jackendoff 1983:196)
- (43) The shadows were turning from grey to black.

To recapitulate, both between and from - to appear in all the four semantic fields. But the occurrences across the fields are constrained by the field-specific properties, and are therefore not perfectly parallel.

6.3.2. Over

That field-specific properties constrain the meaning of a lexical item appearing in that field has an important implication for polysemy analysis. Lakoff (1987) presents a network analysis of over by means of related image-schemas. One of the metaphorical uses analyzed therein is (44).

(44) The play is over.

The over in (44) is claimed to have the image-schema structure shown in Fig. 15.

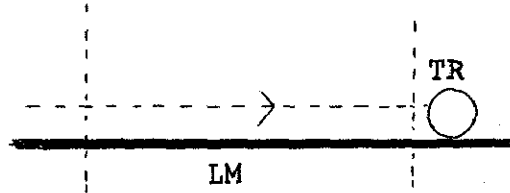

Fig.15

Lakoff states as follows:

In general, activities with a prescribed structure are understood as extended landmarks, and performing such an activity is understood metaphorically as traveling along a prescribed path over that landmark. When one gets to the end, the activity is over. (Lakoff 1987:439-440)

While this account is intuitively appealing, Lakoff does not explain why this must be the case. Notice that many image-schematic structures are available for over in the Spatial field, like the above-across sense as in (45a) or the covering sense as in (45b).

- (45) a. The plane flew over.
- b. The board is over the hole.

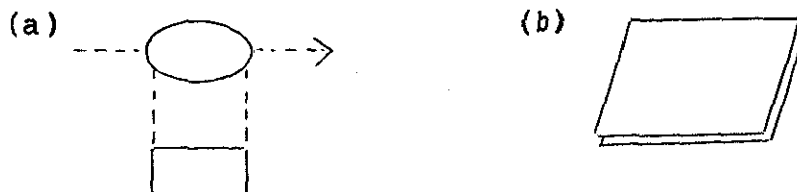

Fig. 16

Is it a pure coincidence that the over in (44) has the schema in Fig. 15, and not some other one?

From my viewpoint, it is not a coincidence at all. On the contrary, the image-schema structure in Fig. 15 is well motivated by properties of the Temporal field. Note that the play denotes an Event. An Event is located on a time line, and we humans are conveyed along the time line from the past to the future. Therefore, the conceptualization in which an Event is a LM, along which we humans, as a TR, travel, is perfectly compatible with the structure of the Temporal field.

Of the many image-schematic structures available for over in the Spatial field, those that involve the vertical dimension or two-dimensional landmarks are not compatible with the one-dimensionality of time. Thus neither the above-across sense nor the covering sense is available for the over in (44).

The same is true of the over in over the weekend. Clark (1973:49) correctly points out that this sense is related to the spatial one like over the line segment, a linear expression without vertical properties. Again, this is due to the inherent structure of the Temporal space, where only one-dimension is available.

This indicates that the polysemy analysis needs to recognize the contribution field-specific properties make to the metaphorically extended meanings. With a proper recognition, one can account for cases which at first sight might appear totally arbitrary.

6.3.3. EXTENT

Let us go on to verb meanings. A number of English verbs exhibit an extent reading.

(46) The road went/extended from Denver to Indianapolis.

In order for the extent reading to obtain, the path must be continuous. The Temporal field, meeting this requirement,

accommodates extent sentences with the schematic structure in Fig. 17 (a).

(47) Ron's speech went/extended/lasted from 2:00 to 4:00.

However, because the Temporal path itself is incessantly moving (=time flow), the Temporal extent sentences describe Events, rather than States (See 4.1.3.).

Identificational space being also continuous, extent sentences are available. Unlike the Temporal path, the Identificational path does not move. Consequently, the Identificational extent sentences describe States, parallel to the Spatial ones.

- (48) a. Our clients range from psychiatrists to psychopaths.
b. This theory ranges from the sublime to the ridiculous.

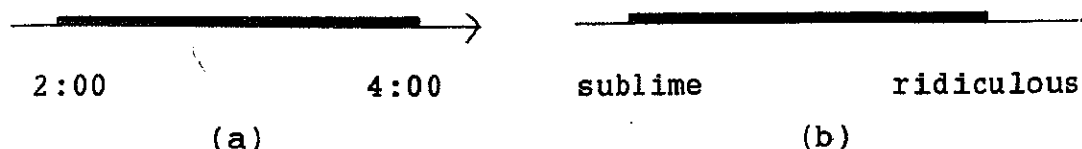

Fig.17

The lack of extent sentences in the Possessional field is probably due to the incompatibility of the discontinuous path with extent sentences.

6.3.4. Spread

Spread in the spatial sense describes an outward movement over a two-dimensional area. Thus the syrup moves out in all directions, as in Fig. 18 (a) (borrowed from Lakoff 1987).

(49) The syrup spread out.

When spread appears in the Possessional field, only the endpoints are available, as in Fig. 18 (b).

(50) He spread the wealth among his five children.

In the Temporal field, the two-dimensional area reduces to a line, as in Fig. 18 (c).

(51) They had experience spreading over twenty years.

(COBUILD)

And in the Identificational field, the path is a line, as in Fig. 18 (d).

(52) Our products spread from a child's tricycle to a two-cylinder motorcycle. (Pittman 1965)

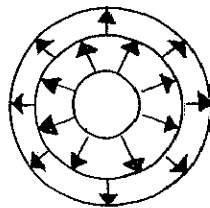

(a)

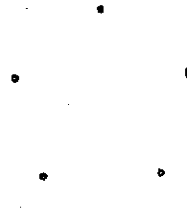

(b)



20 years

(c)



(d)

Fig.18

6.3.5. Around

We have thus far seen that when a lexical item with a basic spatial sense appears in a non-spatial field, only the features compatible with the semantic field remain. This is not limited to thematic parallels, of course, and is true of metaphorical mappings in general.

Take around as an example. Wierzbicka (1986), in distinguishing a number of approximatives, observes that while around applies to a whole area, or a whole period, surrounding a point, as in (53a), about is used as a guess, or an estimate, or a 'shot' at one particular point in time. Thus (53a) refers to a few years, e.g. 1878 - 1883, but (53b) one particular year, viz., 1880.

- (53) a. Hats of this kind were worn in Paris around 1880.
b. Hats of this kind first appeared in Paris (in) about 1880.

Wierzbicka further observes that the idea of 'rounding' is encoded in around, but not in about.

In fact, around 6 or 7 people sounds as if one was rounding some fractional number, such as six and a half, or six and three quarters. (Wierzbicka 1986:603)

These properties of around as an approximative can be traced back to the properties of around in the spatial sense. In the spatial domain around typically indicates a two-dimensional area surrounding the reference object, as in Fig. 19 (a). Now the relevant domain for approximative around is that of quantity, which involves two metaphors, LINEAR SCALES ARE PATHS and MORE IS UP (Lakoff 1990:53). Thus around as an approximative is described as in Fig. 19 (b).

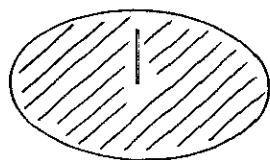

(a) around a tree

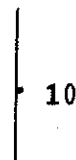

(b) around 10

Fig.19

since only one dimension is available in the quantity space, the two-dimensional area which around is capable of expressing in the spatial domain is reduced to a line in the case of around as an approximative.

Although physical space and quantity space differ with respect to dimensionality, they are both continuous, allowing the sense of vicinity to be preserved in a mapping. Consequently, around as an approximative applies to a whole area surrounding a point on the quantity scale, that is, a number of points: X, and some points a little more than X and some points a little less than X.

6.4. Conclusion

It has been shown that the four semantic fields (Spatial, Temporal, Possessional, and Identificational) have characteristics specific to each field, and that the field-specific properties constrain the cross-field parallelism. While relatively little attention has been paid to the factor of field-specific properties, examination of this factor has important consequences for lexical studies.

Notes to Chapter 6

* The material herein was presented at the 12th Kansai Cognitive Linguistics Colloquium held at Osaka University, June 1994. Section 6.2.1. was also presented under the title "Metaphorical Mapping and Domain Structure" at the First Lund-Gifu Joint Conference on Language and Linguistics, held at Gifu University, September 1994. I'd like to express my gratitude to the audience for their comments and criticisms.

1. Prof. Masa'aki Yamanashi commented that if the concepts of possession do not come from spatial concepts, this begs the question where they ultimately come from. Jackendoff (1992) argues that some parts of the concepts of possession are learned from observation or instruction, but some parts are

innate:

But, as I am continuing to emphasize, the fundamental relation of possession and the fundamental notion of a right cannot be learned from observation or instruction — they have to be available innately in the Conceptual Well-Formedness Rules in order to be on one hand culturally universal and on the other hand culturally modulated. (Jackendoff 1992:66)

2. An apparently problematic case is down as in (i).

(i) from the Middle Ages down to the present

However, this does not lead to the conclusion that time has a vertical dimension. This sense of down seems to be based on the conceptualization of time as a flow in the river, which is superimposed on the time as a line. Up the river and down the river mean the directions of its source and its end (=near the ocean), respectively, rather than locations on the vertical dimension.

3. The conceptualization of time as linear seems to be universal. Comrie (1985:5) argues as follows:

Moreover, even in societies that have a cyclic concept of time, the individual cycles seem to be viewed as chronologically arranged, i.e. there are earlier and later cycles, so that at best the cyclicity would be superimposed on an overall conceptualization of time that is linear.

4. This is the approach taken in Lakoff (1990, 1992). Jackendoff (1983:191) and Seto (1995:98-99) also view the two movements as unrelated.

5. Marianne Gullberg (personal communication) has pointed out that the two interpretations have gestural correlates. Depending upon the metaphor chosen, the speaker either points to him/herself (moving time) or moves his/her hand forward (moving ego).

6. Lynne Roecklein (personal communication) has pointed out that (19) becomes acceptable if John was on the plane which

was crossing the date line.

PART IV
Application

Introduction to Part IV

Part I has established the necessity of a dual network, and Parts II and III have examined in detail some of the links constituting the network.

Chapter 2 has shown that locative alternation is a conceptual gestalt shift which is to be captured in the form-meaning correspondence model crucially resting upon the L-meaning/P-meaning distinction. This form-meaning correspondence model seems to work well for other linguistic phenomena, as shown in Chapter 3.

Chapter 4 has shown that GO and GO_{EXT}, semantic functions for motion and extent senses respectively, are distinct but share a great deal of internal structure, and that, with suitable modifications, these functions can be applied to verb meanings which have received relatively little attention in the literature.

Chapters 5 and 6 have shown that in an account of a domain shift, the main S-network link, reference to domain specific properties is essential.

These findings give us a picture of an integrated lexical network theory. Thus one characteristic of the generative lexical semantics literature is its reliance on algebraic expressions and non-use of pictorial representations. But this does not mean that the generative lexical semantics literature is totally at odds with Cognitive Linguistics.

An important implication of the L-meaning/P-meaning distinction is that not every aspect of meaning can be represented in an algebraic expression like conceptual argument structure. Frame semantic meanings, which are not always amenable to formal representation, can play a crucial role in so-called argument structure alternations. Therefore, both conceptual argument structures and pictorial representations are necessary.

In Part IV, the integrated lexical network theory will be

further developed via several case studies, which intended not only to demonstrate the adequacy of a network approach but also to find out further constituting the network.

Chapter 7

Pass*

7.1. G-Network

7.1.1. Jackendoff (1987)

Jackendoff (1987:390) presents the following analysis of pass. Pass may appear in three syntactic frames: with a null complement, with a direct object, and with a PP.

- (1) a. The train passed.
b. The train passed the station.
c. The train passed { through the tunnel.
under the bridge.
etc.

The transitive use in (1b) roughly means 'to go via near', so that its conceptual structure is (2).

- (2) [Event GO([Thing]₁, [Path VIA([NEAR([Thing]₁)])])]

As for the intransitive use in (1c), its PP complement is restricted to Routes — essentially Paths whose Path-function is VIA. Source, Goal, and Direction expressions are not allowed.¹

- (3) *The train passed { (away) from the station.
to the station.
toward the station.
northward.

Jackendoff thus posits the following lexical entry for the verb pass, which is intended to be the combination of the three conceptual structures for (1a), (1b), and (1c).

- (4) $\left[\begin{array}{l} \text{pass} \\ [-N, +V] \\ \text{--- (XP}_1\text{)} \\ [\text{Event GO}([\text{Thing }]_1, \\ \quad [\text{Path VIA}([\text{Place (NEAR}([\text{Thing }]_1\text{)}])])]) \end{array} \right]$

While this analysis is presented in the context of showing how abbreviatory conventions work in unifying multiple uses into a single entry, it suffices for the present purposes to point out that there are three passes which are distinguished in terms of post-verbal complements.²

- (5) The train passed. (A)
 [GO([TRAIN],[AWAY])]
 (6) The train passed the station. (B)
 [GO([TRAIN],[PAST STATION])]
 (7) The train passed through the tunnel. (C)
 [GO([TRAIN],[VIA TUNNEL])]

7.1.2. Other Senses

In addition to the above three, we have a fourth use.

- (8) I passed the rope through the ring. (D)

Unlike the above three, the direct object NP rather than the subject NP is asserted to move. This sense can be paraphrased as 'to cause to pass', yielding the following representation.

- (9) [CAUSE([I],[GO([ROPE],[VIA RING])])]

The extent sense is available as well.

- (10) The route passes through the city. (E)

As argued in chapter 4, the extent sense is represented by

means of a related but different function GO_{Ext} .

(11) [GO_{Ext} . ([ROUTE],[VIA IN CITY])]

Thus we have five senses of pass in the Spatial field.

7.2. S-Network

7.2.1. Temporal

In the Temporal field we find the following three senses of pass, which will be referred to as (F), (G), and (H).

- (12) a. The time has passed. (F)
b. He passed the time. (G)
c. He passed through four years of much
bitterness. (H)

These three senses are distinguished from each other in terms of the complement: a null complement (F), a direct object (G), and a PP complement (H), respectively. All the three can be analyzed as GO-verbs as below.

- (13) The time has passed.
[GO_{Temp} ([TIME],[AWAY])]
(14) He passed the time.
[GO_{Temp} ([HE],[PAST TIME])]
(15) He passed through four years of much bitterness.
[GO_{Temp} ([HE],[VIA FOUR YEARS])]

In view of the complement frames and the GO-function, (F), (G) and (H) can be said to be temporal counterparts of (A), (B), and (C), respectively.

Yet there is one thing which keeps us from just saying blithely that (F) - (H) are temporal. (F) contrasts sharply with (G) and (H) with regard to the choice of theme (i.e. an entity 'in motion'): With (F) time occupies the first

argument slot of GO, while with (G) and (H) a human being appears there.

This difference reflects a difference in conceptualization. Time is conceptualized as a moving entity with (F), but as a location with (G) and (H). Thus two different conceptualizations are involved here, although all the examples are temporal.

This is not surprising, for the two conceptualizations have been noted in the literature (Fillmore 1971, Clark 1974, Lakoff and Johnson 1980 etc.). Thus Lakoff and Johnson (1980) present the following examples illustrating the two ways to conceptualize the passage of time.

- (16) a. The time will come when ...
The time has long since gone when ...
The time for action has arrived.
- b. As we go through the years, ...
As we go further into the 1980s, ...
We're approaching the end of the year.

(Lakoff and Johnson 1980:44)

In (16a) time is a moving object, while in (16b) we humans are moving and time is standing still. The two conceptualizations coexist, despite the different claims as to what moves, because they are obtained through alternate construals of the same conceptual scene, as demonstrated in chapter 6: We humans are conveyed on the time flow in the direction of future. Thus either we humans go through the time that is stationary relative to our movement, or else we remain conceptually stationary while the time travels past us.

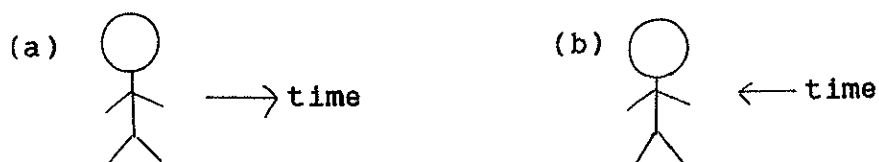

Fig. 1

Thus the MOVING TIME metaphor and the MOVING EGO metaphor are aspects of the same model of time.

Now the account of pass goes as follows. Pass has a GO-function as an essential part of its meaning. When this function is combined with the MOVING TIME metaphor, the first argument is time and (F) is obtained. When it is combined with the MOVING EGO metaphor, we humans occupy the first argument position of GO, yielding (G) and (H).³

7.2.2. Possessional

Let us go on to the Possessional field. Possession divides into alienable possession and inalienable possession, the latter further subsuming ownership and temporary control. The following pass is an instance of ownership.

- (17) Her property passes to her son. (I)
[GO_{POSS} ([HER PROPERTY],[TO HER SON])]

Pass may also appear in the following frames, parallel to give:

- (18) a. She passed the letter to him. (J)
b. She passed him the letter. (K)

Following Pinker (1989) and Goldberg (1992a, 1992b), I maintain that the syntactic frames V NP₁ to NP₂ and V NP₂ NP₁ are associated with different semantic structures. I thus represent the two senses as in (19) parallel to give.⁴

- (19) a. [CAUSE([SHE],[GO_{POSS} ([LETTER],[TO HE])])]
b. [CAUSE([SHE],[INCH[BE_{POSS} ([LETTER],[AT HE])])]]

These senses involve temporary control rather than ownership. (J) may be said to be a causative counterpart of (I) in view

of the functional structure, although the notion of possession is not exactly of the same kind.

7.2.3. Identificational

Another semantic field, Identificational, concerns categorization and ascription of properties. In this field pass comes to express the change of state.

- (20) Water passes from a liquid to a solid state when it freezes. (L)
[GO_{Ident} ([WATER],[FROM LIQUID TO SOLID])]

7.2.4. Existential

The following well-known expression counts as a sense in the existential field.

- (21) He passed away at eighty. (M)
[GO_{Exist} ([HE],[OUT OF EXISTENCE])]

7.2.5. Linear Scales

The following expression can be analyzed as a GO-verb as well.

- (22) Contributions passed \$800. (N)
[GO([CONTRIBUTION],[PAST \$800])]

What is behind this expression is the LINEAR SCALES ARE PATHS metaphor (Lakoff 1990:53). Thus the reference object of the Path is a particular point on a scale, and the quantity of contributions goes past that point.

7.2.6. Conduit Metaphor

Consider next (23), which means 'to say, to deliver'.

- (23) He passed a remark. (O)

This sense parallels (D) in that the direct object denotes a moving entity, suggesting that it can be analyzed as CAUSE-GO. In (23) a remark comes out of the subject he, so that (23) receives (24) as its representation.

(24) [CAUSE([HE],[GO([REMARK],[FROM HE]])]]

It should be noticed that the conceptualization involved here is that having to do with verbal communication in general: what Reddy (1979) calls the conduit metaphor. That is, the speaker puts ideas (objects) into words (containers) and sends them (along a conduit) to a hearer who takes the idea/objects out of the word/containers.

Reddy divides the conduit metaphor into two parts i.e. the major framework and the minor framework. Of these two, the minor one is relevant for the present discussion. There are three subcategories in the minor framework: (a) ideas are ejected by speaking or writing into an external "idea space"; (b) ideas are reified in this external space; and (c) these reified ideas may or may not find their way back into the heads of living humans. Among these, the subcategory (a) is the conceptualization underlying (O): A remark (i.e. idea) is ejected by speaking from within the speaker to an external space.

This conceptualization comprises two metaphors. On the one hand, the speaker is conceptualized as a container for ideas, with a bounding surface and an in-out orientation, viz. PEOPLE ARE CONTAINERS. On the other, ideas are regarded as moving objects, which come out of the speaker. Hence IDEAS ARE OBJECTS.

The following sense (P) can be analyzed analogously.

(25) No secrets passed her lips. (P)
[GO([SECRET],[PAST HER LIPS])]

The function is GO, but the conceptualization involved is the same: The information comes out of the speaker. The direct object her lips is to be construed not as a physical entity taken in isolation but as that part of a human body through which a message is ejected. Accordingly, for a message to go past one's lips is part of the whole process of ejecting a message. In this sense, pass one's lips metonymically stands for the process of being uttered.

Next, the subcategory (b) is to be found in the following:

- (26) The story passed from person to person. (Q)
 [GO([STORY],[FROM PERSON TO PERSON])]

Neither the speaker nor the hearer is within the scene. Rather the transmission of the story (i.e. idea) among people comes to the fore. The speaker as source of the information being lacking, the metaphor is IDEAS ARE OBJECTS alone.

The relationships of the seventeen senses of pass are described as in Fig. 2.⁵

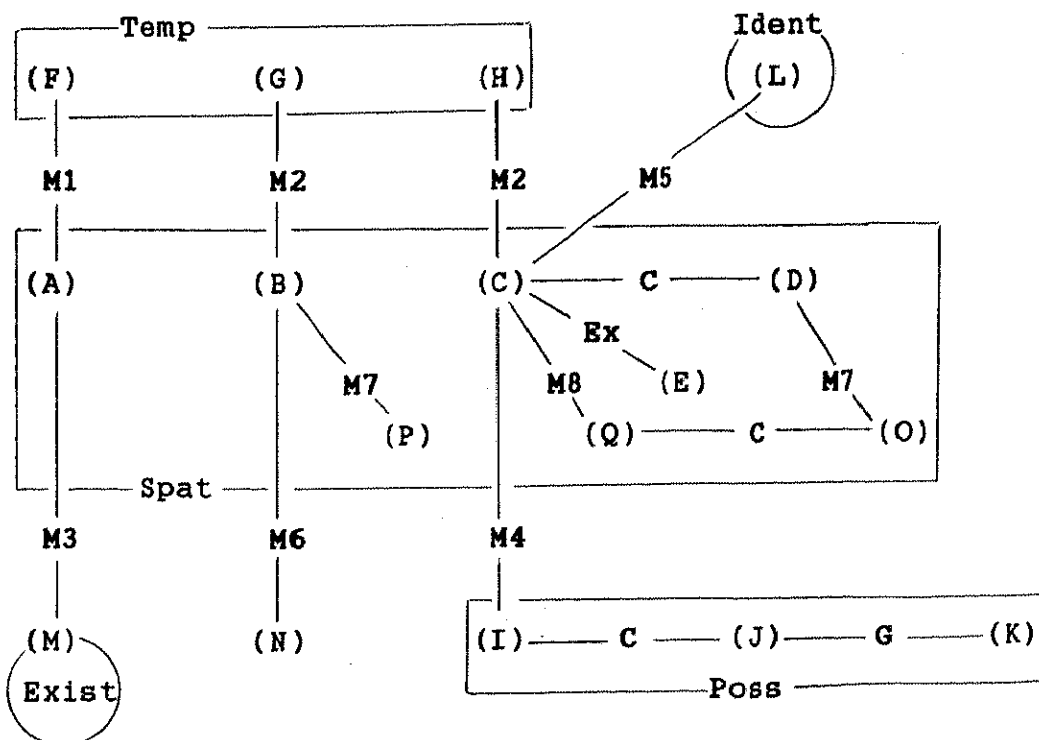

C: causative-pair G: gestalt shift
 Ex: GO/EXTENT alternation
 M1: TIME IS A MOVING OBJECT
 M2: TIME IS STATIONARY AND WE MOVE THROUGH IT
 M3: EXISTENCE IS LOCATION HERE
 M4: BEING POSSESSED IS LOCATION
 M5: PROPERTIES ARE LOCATIONS
 M6: LINEAR SCALES ARE PATHS
 M7: IDEAS ARE OBJECTS + PEOPLE ARE CONTAINERS
 M8: IDEAS ARE OBJECTS

Fig. 2

7.3. Further Senses

All the senses seen so far are analyzed by means of GO (or GO_{EXT}) or its causative counterpart. There are still several other senses that can be handled along the same lines, which I will just briefly touch upon.

During a game of football etc., you pass the ball to someone else in your team. This sense is represented as follows:

- (27) Robson passes to Lineker on the right wing.
 [CAUSE([ROBSON],[GO([BALL],[TO LINEKER]))]]

When you cannot answer the question or when you are unwilling to take part in the next stage of a game, you also use the word 'pass'. In that case, what is passed is your turn: This sense can be paraphrased as 'to let one's turn go by', leading to the conceptual structure in (29).

- (28) He refused to play the next round. 'I pass,' he
 said.
 (29) [LET([I],[GO([MY TURN],[AWAY]))]]

The following sense can be analyzed by means of the same function as well.

- (30) He passed blood in his urine.
[LET([HE],[GO([BLOOD],[FROM HE]])]]

Blood comes from within the human body (more specifically, the kidneys), so the metaphor involved here is PEOPLE ARE CONTAINERS.

Finally, we have the following expression.

- (31) The candidates passed the examination.

An examination is a difficult area to go through, and passing it means succeeding in the examination. The same is true of (32).

- (32) The examiners passed most of the candidates.

(32) can be paraphrased as 'The examiners let the candidates pass the examination,' suggesting that (31) and (32) can be represented as (33a) and (33b), respectively.

- (33) a. The candidates passed the examination.
[GO([CANDIDATES],[PAST EXAMINATION]])
b. The examiners passed the candidates.
[LET([EXAMINERS],[GO([CANDIDATES],
[PAST EXAMINATION]])]]

Quite probably, the following are to be analyzed analogously.

- (34) a. The bill passed and became law.
b. Parliament passed the bill.

Notes to Chapter 7

*This chapter is a slightly revised version of Iwata (1991).

1. Yukio Hirose (personal communication) has pointed out that even such prepositions as from and to are possible when the Path which the PP denotes is construed as a Route. Thus pass from door to door is perfectly acceptable.

2. For expository purposes, the Path functions are abbreviated as AWAY, PAST, and VIA.

3. Alternatively pass (G) could be paraphrased as 'to cause the time to go by'. This is in fact the explanation given in Longman Dictionary of Contemporary English. In that case, the function would be CAUSE-GO and the metaphor TIME IS A MOVING OBJECT. But this alternative analysis does not seem promising. First, in the TIME IS A MOVING ENTITY metaphor time moves on its own along a time line, and its movement cannot be under any human control. Second, the notion of control is not salient in (G). If anything, the causative analysis seems to be appropriate for spend. Note the contrast *Pass the time/Spend the time (I am indebted to Yukio Hirose for this insight).

4. This does not mean that pass's (J) and (K) are totally identical to give, of course. Pinker (1989) argues that the semantic field of give is "possessional", whereas that of pass is "possessional: physical custody"; One can give, but not pass, someone by signing a title transfer agreement. One can pass, but perhaps not give, an object which one doesn't own.

5. (O), (P), and (Q) are included among the spatial field because all the three senses focus on the uttering of sounds, rather than the communication of ideas. In this sense they all belong to the say class, not the tell class. Gruber (1976) attributes the difference between say and tell to that between Spatial and Possessional fields: What is told is necessarily subsequently heard (i.e. the information comes to

be possessed by the hearer), whereas what is said need not be understood (i.e. the information as a sound reaches the hearer). This insight is elaborated by Pinker (1989).

Chapter 8

Extend*

8.1. Two Senses of Extend

8.1.1. Jackendoff (1983)

Let us begin by reviewing the analysis of Jackendoff (1983). Jackendoff analyzes extend as an instance of the GO_{EXT} function in (2), parallel to other extent verbs like reach (1b) or go (1c).

- (1) a. The highway extends from Denver to Indianapolis.
- b. The flagpole reaches (up) toward the sky.
- c. The sidewalk goes around the tree.

(2) [state GO_{EXT} ([Thing x],[path y])]

(Jackendoff 1983:172)

He further argues that sentences in (3a) are temporal counterparts of the spatial expressions of extent in (3b), and thus represents them as in (4).

- (3) a. Ron's speech went/extended/lasted from 2:00 to 4:00.
- b. The road went/extended from Denver to Indianapolis. (Ibid:190)

(4) [state $GO_{EXT,Temp}$ ([Event SPEECH],

[FROM_{Temp} ([Time 2:00])
 [path TO_{Temp} ([Time 4:00])])]

(Ibid:191)

GO_{EXT} is subscripted with Temp, indicating that the function is applied to the Temporal domain.

To give substance to this claim, Jackendoff draws attention to the shared inference patterns: The function GO_{EXT} , expressed in (3b), asserts that the Thing occupies every

point of the Path. When shifted into the temporal domain as in (3a), GO_{EXT} asserts that the Event occupies all points in time within the temporal Path.

8.1.2. Problems

The above analysis has two problems. First, although the representation in (4) is subscripted with State, the sentences in (3a) describe Events. The representation is to be modified accordingly.

Second, and more important, the above analysis does not distinguish between extent senses of go and extend. It is true that in (3b) both go and extend describe the subject's extent, rather than the subject's motion: The subject (the road) occupies every point of the path at a single point in time. Yet extend inherently involves the sense of an object gradually becoming larger. Thus quite often extend can be paraphrased by spread, stretch, etc., indicating that it forms a semantically natural class with these verbs.

Extend in (3b) describes a State, where the sense of enlargement might not be so clear. To make the difference between the extent senses of go and extend clearer, let us compare the eventive sense of the extend class, on the one hand, with motion and extent senses in (5), on the other. Jackendoff posits the GO_{EXT} function to capture the relatedness of motion and extent senses in (5).

- (5) a. John went from Denver to Indianapolis.
b. The road goes from Denver to Indianapolis.

The motion sense in (5a) can be characterized as describing a change of location along with the passage of time. The mover, J (= John), is at location l_0 at time t_0 . At the next moment t_1 J is at l_1 , and at t_2 J is at l_2 , and so on. The mover cannot be in more than one place at a time.

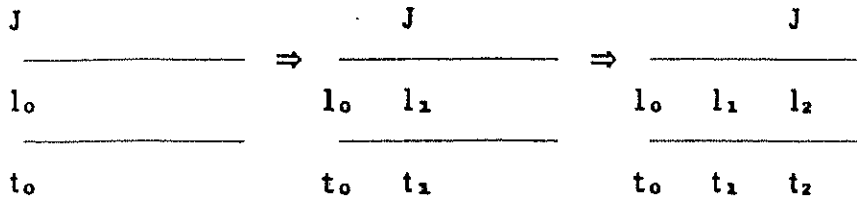

Fig. 1

In contrast, the extent sense in (5b) does not involve objective movement of the subject. Rather, the conceptualizer/speaker mentally moves along the path, independent of the passage of time. The conceptualizer first conceives of that part of the road which is at l_0 , then moves on to that part of the road which is at l_1 , and so on. R (= the road) occupies more than one location (See Chapter 4, Langacker 1986, 1987, Honda 1992).



Fig. 2

Now consider verbs like spread and stretch, which describe the change of a single object.

(6) The goo is spreading out. (Lindner 1983:92-93)

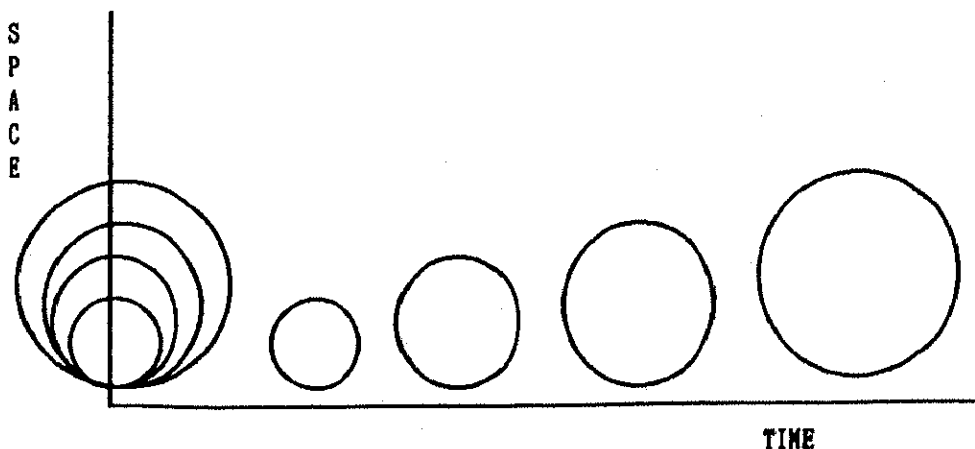

Fig. 3

(7) Stretch out the rope. (Lindner 1983:94)

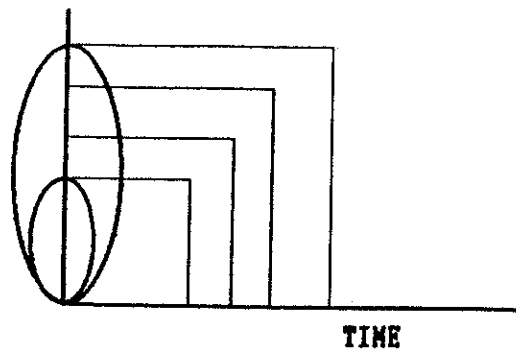

Fig. 4

These are instances of reflexive OUT (Lindner 1983:92). Thus in (6) the goo, or at least part of it, is moving "out" relative to its own prior boundary. The object changes from some initial form to a final form that occupies a greater area than the initial area.

The progressive enlargement of an object can be described as in Fig. 5. The object G (= the goo) occupies l_0 at t_0 . At t_1 , the object becomes larger and occupies l_1 as well. And at t_2 , it becomes even larger, reaching l_2 , and so on.

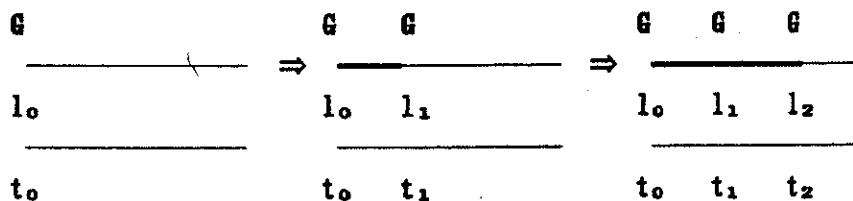

Fig. 5

Fig. 5 is like Fig. 2 in that the entity denoted by the subject occupies more than one location. Yet Fig. 5 is like Fig. 1 in that the enlargement process proceeds along with the passage of time. In any case Fig. 5 is not perfectly identical to either Fig. 1 or Fig. 2, and one cannot just blithely posit GO_{EXT} for the class of verbs like extend.

8.1.3. Alternative Analysis

How are verbs like extend to be represented, then? One

possibility might be to introduce a new function that expresses the sense of enlargement. Rather than proliferate functions, however, I choose a different solution. GO coupled with a reflexive path represents an object's enlargement, and I propose to regard the enlargement process as a subtype of motion. This amounts to saying that the sense of motion is to be taken broadly enough to encompass that of enlargement, although the term 'motion' tends to be construed as involving two distinct objects together with a linear path.

As can be seen from comparison of Fig. 1 with Fig. 5, the enlargement process is analogous to the motion sense, their difference being the enlargement Theme can occupy more than one location.¹ The Theme undergoing enlargement is an object that is malleable or stretchable,² so it is possible for part of the Theme to move out relative to some other part of the same Theme. Thus the sense of enlargement can be adequately expressed by GO, which incorporates a reflexive path, rather than by a new function.

It seems preferable to represent a reflexive path as parallel to a non-reflexive path, for there is a systematic relationship between them. As Lakoff (1987:442) points out, several particles alternate between reflexive (RF) and non-reflexive (NRF) senses.

- | | | |
|---------|---|-------|
| (8) a. | He stood <u>apart</u> from the crowd. | (NRF) |
| | b. The book fell <u>apart</u> . | (RF) |
| (9) a. | She walked <u>up</u> to me. | (NRF) |
| | b. Let's cuddle <u>up</u> . | (RF) |
| (10) a. | She poured the syrup <u>out</u> of the jar. | (NRF) |
| | b. The syrup spread <u>out</u> over the pancakes. | (RF) |

(Lakoff 1987:442)

Thus relevant parts of the representations for (10a) and (10b) will be as in (11a) and (11b), respectively.³

- (11) a. [GO([SYRUP],[OUT-FROM([JAR])])]
 b. [GO([SYRUP],[OUT-FROM([SYRUP])])]

(11b) can be rewritten as (12) by using the mechanism of argument binding, which establishes a coreference relation between conceptual positions by means of Greek letter co-indexing (Jackendoff 1990:63).⁴

- (12) [GO([SYRUP]^α, [OUT-FROM([α])])]

Let us now go back to the two senses of extend.

- (13) a. The road extends from Denver to Indianapolis.
 b. Ron's speech extended from 2:00 to 4:00.

(13a) is represented as in (14).

- (14) [_{state} GO_{Ext} ([ROAD]^α,
 [OUT-FROM([α])
 FROM([DENVER]) TO([INDIANAPOLIS])])]

(13a) expresses a State, as evidenced by the simple present tense. And it is an instance of GO_{Ext}, as Jackendoff analyzes, for the inference pattern is clearly that of GO_{Ext}: The road occupies every point of the path at a single point in time. Yet a reflexive path needs to be specified as well, which expresses the sense of progressive enlargement. Hence an extent version of enlargement.

(13b) is similarly represented as in (15).

- (15) [_{Event} GO_{Ext,Temp} ([SPEECH]^α,
 [OUT-FROM([α])
 FROM([2:00]) TO([4:00])])]

As noted above, (13b) expresses an Event. GO_{Ext} normally

expresses a State, but when applied to the Temporal field, it may denote an Event as in (13b). This is due to the introduction of a specific passage of time (in this case, from 2:00 to 4:00) (See Chapter 4). When the temporal path is not specific, GO_{Ext} expresses a State even in the Temporal field.

- (16) His working day often extends well into the evening. (COBUILD)

8.2. Extending the Analysis

The last section has presented an analysis of the two senses of extend, repeated here as (17a) and (17b). For convenience, let us henceforth refer to them as extend (A) and extend (B), respectively.

- (17) a. The road extended from Denver to Indianapolis.
=> (A)
b. Ron's speech extended from 2:00 to 4:00.
=> (B)

In this section I will extend the analysis to cover senses other than (A) and (B).

8.2.1. G-Network

8.2.1.1. Extend (C)

Extend has a sense, exemplified in (18), which is paraphrasable as 'to make something larger.' This sense will be referred to as extend (C).

- (18) a. extend a fence => (C₁)
b. extend the ladder => (C₂)

Extend (C) has two subtypes according to how the object becomes larger. One means 'to add to,' as in (18a) (extend

(C₁)). The other codes conversion from compacted form to the full, canonical form, as in (18b) (extend (C₂)).

(a) extend a fence

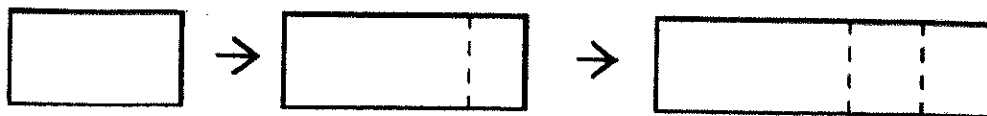

(b) extend a ladder



Fig. 6

What does the representation look like? Evidently this sense is a causative of extend (A), so the main function is naturally CAUSE. CAUSE embeds an Event as its second argument, but extend (A) describes a State. A usual strategy taken in relating a state sense to its causative is to use an inchoative operator INCH, which maps a State onto an Event that terminates in the State. By using INCH, the state function GO_{EXT} can be embedded inside CAUSE as in (19).

(19) [Event CAUSE([],
[INCH[State GO_{EXT} ([]^x, [OUT-FROM([α]])]])]]

But this representation mentions the end state alone, meaning 'to cause something to come to be in an enlarged state,' not the correct meaning. A more reasonable representation will be (20).

(20) [Event CAUSE([], [Event GO ([]^x, [OUT-FROM([α]])]])]

The trick is to replace GO_{EXT} with GO. (20) correctly means 'to cause something to become gradually larger.'

Incidentally, consideration in terms of lexical relatedness lends additional support for the representation's

incorporating a reflexive path. If the representation for extend (A) is just GO_{EXT} without a reflexive path as in (21a), as Jackendoff analyzes it, then its causative counterpart will be (21b), which does not express the correct meaning of extend (C).

- (21) a. [state GO_{EXT} ([], [])]
 b. [Event CAUSE ([], [INCH[state GO_{EXT} ([], [])])]]

It is necessary to specify a reflexive path in the representation for extend (C) as in (20). But then the relatedness between (21a) and (20) will not be immediately obvious.

In contrast, in my analysis both extend (A) and extend (C) contain a reflexive path, rendering the relatedness much clearer.

- (22) a. [state GO_{EXT} ([]^α, [OUT-FROM([α])])]]
 b. [Event CAUSE([], [Event GO ([]^α,
 [OUT-FROM([α])])])]]

8.2.1.2. Extend (D)

In the above examples, the object undergoing enlargement is distinct from the person engaged in the activity of extending it. But we humans can extend parts of our own bodies, typically our arms, as in (23).

- (23) The gymnast extended her arms horizontally. (OALD⁴)

Now consider (24), where his hand appears as direct object, although what was actually stretched out is his arm.

- (24) a. He extended his hand, and Brody shook it.
 (COBUILD)
 b. He extended his hand to the new employee.
 (OALD⁴)

(23) and (24) are related via profile shift, i.e. profiling different facets of the same situation described by the verb (Langacker 1987, 1991). Thus in (24) one's hand as well as one's arm are put in profile. When further profile shift occurs, what is held in one's hand appears in direct object position.

(25) I extended the document to the judge. (COBUILD)



Fig. 7

In (25) extend comes to mean 'to proffer,' distinct from (but related to) extend (C). This sense, referred to as extend (D), is represented as in (26).

(26) [CAUSE([I],[GO([DOCUMENT],[TO JUDGE]])]]

8.2.2. S-Network

8.2.2.1. Extend (E)

While extend changes from a GO_{EXT}-verb to a GO-verb through the progression from extend (C) to extend (D), it still expresses a concrete, spatial meaning. When the progression goes further into the non-spatial domain, extend acquires the syntax and semantics of give.⁵ Thus non-physical objects may occur in direct object position as in (27).⁶

(27) They extended a warm welcome to her. (OALD⁴)

This sense, referred to as extend (E), is represented as in (28), parallel to give.

(28) [CAUSE([THEY],[GO_{PROSS} ([WELCOME],[TO HER]])]]

The following are also instances of extend (E).

- (29) a. extend aid to those in need
b. extend my thanks

8.2.2.2. Extend (F)

The parallel with give goes even further. Extend may appear in the double object construction.

- (30) They extended the Queen a warm welcome. (OALD*)

I follow Pinker (1989) and Goldberg (1992a, 1992b) in assuming that the syntactic frames V NP₁ to NP₂ and V NP₂ NP₁ are associated with different semantic structures. I thus represent (30) as (31), in line with the claim that the double object construction means 'to cause to have' (Pinker), or 'to cause to receive' (Goldberg).

- (31) [CAUSE([THEY],[INCH[BEFORE] ([WELCOME],
[AT QUEEN])]])]

8.2.2.3. Extend (G)

Now let us go back to the basic sense of extend as a verb of extent. Recall that extend (B) is a Temporal counterpart of extend (A): They share the functional structure GO_{EXT}, their difference being that the field modifier of (B) is Temporal and that of (A) Spatial. This relatedness is just what the Thematic Relations Hypothesis is intended to capture (cf. Jackendoff 1983). We have another instance of GO_{EXT} applied to a non-Spatial semantic field.

- (32) They order the manifold levels of reality and moral value along an axis of being which extends from brute matter to the immaculate stars.
(Brown Corpus)

This sense, referred to as extend (G), is an Identificational counterpart of extend (A).

(33) [state GO_{Ext, Ident} ([AXIS]^α,
 [OUT-FROM([∞])
 FROM([BRUTE MATTER]) TO([IMMACULATE STAR])])]

8.2.2.4. Extend (H)

Now consider the following sense, extend (H), which is paraphrasable as 'to cause something to exist for a longer period of time.'

(34) Can you extend your visit a few days longer? (OALD⁴)

Extend (H) is a temporal counterpart of extend (C₁): An Event is located on a time line with a certain duration (See 6.2.1.). Extending a visit means making longer the period of time the visit takes than was originally scheduled.

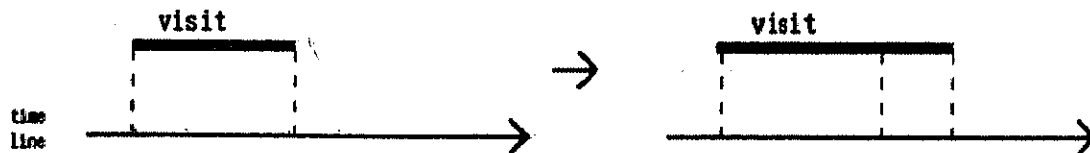

Fig. 8

Consequently, extend (H) is represented as in (35).

(35) [event CAUSE([YOU],
 [Event GO_{Temp} ([Event VISIT]^α, [OUT-FROM([∞])])])]

8.2.3. The Network of Extend

The relatedness between the senses of extend is expressed in Fig. 9.

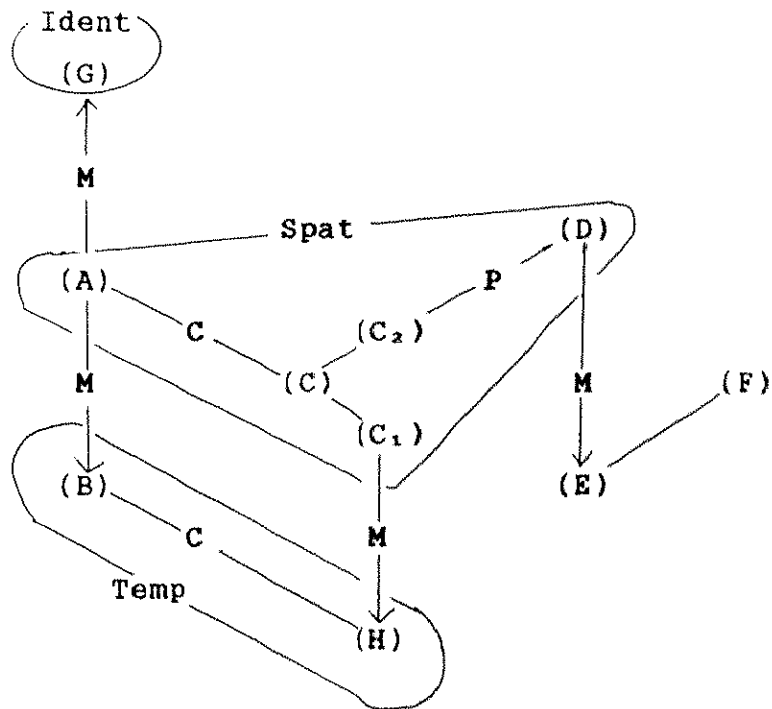

C: causative M: metaphor(domain shift)
P: profile shift

Fig. 9

Notes

* This chapter is a reprint of Iwata (1995a). I'd like to express my gratitude to Lynne Roecklein, who provided me with many insightful observations.

1. Here a Theme is meant as an entity whose spatial location is asserted in each component state of Figs. 1, 2, and 5. I use the term Theme rather than 'mover,' which might be misleading.

2. This information is written inside the conceptual constituent as a selectional restriction (cf. Jackendoff 1990:52).

3. The overall conceptual structure for pour is as in (i).

(i) [CAUSE([SHE],[GO([SYRUP],[OUT-FROM([JAR])]])])]

4. The coindexing in (12) is not without problems: It says just that the two conceptual positions are filled in by the same material SYRUP, and does not capture the fact that the

two occurrences of SYRUP actually denote different parts of the syrup.

But this is a problem for interpreting reflexives in general. In many cases referents of a reflexive and its antecedent NP are not strictly identical e.g. shave oneself, wash oneself. Perhaps we need a theory of reflexives, which involves more than mere coindexing.

5. Fillmore and Atkins (1992:96-97) observe that a word can have distributional and semantic properties that overlap the properties of other words (or word-classes). Extend (E) is an example of such 'derivative syntax.'

6. Lynne Roecklein (personal communication) has pointed out a strong correlation between the indefinite article and a metaphorical interpretation. Thus (i) means 'to help' to the exclusion of 'to stretch out,' although it is apparently the same as (24b).

(i) He extended a hand to the new employee.

Chapter 9
The Story of Cover*

9.1. Spatial Senses

Cover has the three basic senses in (1). For convenience, I will henceforth refer to them as cover (A), (B), and (C).

- (1) a. Snow covers the ground. (stative) =>(A)
b. Snow covered the ground. (inchoative) =>(B)
c. Bill covered the ground (with a tarpaulin). =>(C)
(causative inchoative)

Cover (A) expresses a State, whereas cover (B) denotes a change taking place whose final state is what is expressed by cover (A). Cover (C) is a causative counterpart of cover (B). Jackendoff (1990:160-161) provides the following representations for the three senses.

- (2) a. [state BE([SNOW],[ON_d[GROUND]])]
b. [event INCH[state BE([SNOW],[ON_d[GROUND]])]]
c. [event CAUSE([BILL],[event INCH
[state BE([TARPAULIN],[ON_d[GROUND]])]])]

The subscript d stands for a distributive location, so that (2a) means that the Theme is all over (ON_d) the reference object.¹ The State expressed by (2a) is embedded as the argument of INCH in (2b). The INCH-function in turn is embedded as the second argument of CAUSE in (2c). Thus the three senses are linked via two alternations, viz. an inchoative alternation between (2a) and (2b) on the one hand and a causative alternation between (2b) and (2c) on the other.

While Jackendoff's analysis is motivated by the need to accommodate the two alternations, his analysis of cover (C) as a causative inchoative is compatible with my view of the

locative alternation. As argued in Chapter 2, a necessary criterion for a verb to participate in the locative alternation is that it specify or allow one to predict both a type of motion and an end state, and verbs which do not encode both aspects of meaning fail to enter into the alternation. Thus while pour, specifying a motion alone, appears only in the into/onto form, fill, specifying an end state alone, appears only in the with form.

- (3) a. Irv poured water into the glass.
 b. *Irv poured the glass with water.
- (4) a. *John filled water into the glass.
 b. John filled the glass with water.

Within Jackendoff's framework, CAUSE-GO expresses a change of location, while CAUSE-INCH a change of state. It follows therefore that a GO-verb appears in the into/onto form alone, while an INCH-verb in the with form alone. Like fill, cover appears in the with form alone, indicating that it is an INCH-verb.

- (5) a. *Bill covered a tarpaulin over the ground.
 b. Bill covered the ground with a tarpaulin.

This consideration lends independent support for relating the three senses of cover by means of two alternations, as Jackendoff does. I thus accept Jackendoff's analysis as basically correct. The three senses are related as in Fig.1.

cover (A) — IN — cover (B) — C — cover (C)

IN: Inchoative

C: Causative

Fig.1

9.2. Further Senses

The three senses of cover in the last section are adequately handled by means of conceptual argument structure in the sense of Jackendoff. This section deals with those senses of cover which ought to be analyzed by different mechanisms.

9.2.1. Cover (D), cover (E), and cover (F)

Traditional rhetoric defines metonymy as a figure of speech whereby the name of one entity e^1 is used to refer to another entity e^2 which is contiguous to e^1 . In the cognitive semantics literature, the notion of metonymy is extended to include cases where the entities are not contiguous in any spatial sense, or where no referring function is involved (Lakoff 1987, Taylor 1989, etc.).² On this broader view, the essence of metonymy resides in establishing connections between two entities.

In many instances of metonymic extension, the two entities being connected stand in a part-whole relation, or something similar to it. Such connections result from perspectivizing a component of a unitary conceptual structure (Taylor 1989:125-126). Some senses of cover seem to be cases of metonymic extension through what might be called the 'perspectivization of an implication'. Cover (C), repeated here as (6), profiles the process of putting or spreading something over something else.

(6) Bill covered the ground with a tarpaulin.

But if one covers something, what is covered is, by implication, put in a place where it cannot easily be seen or noticed, or where it is safe from injury, damage, or other unpleasant effects or events.

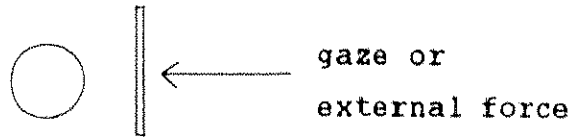

Fig.2

Through a perspectivization of these implications, cover comes to mean 'to hide' as in (7a) or 'to protect' as in (7b). I will refer to these senses as cover (D) and cover (E), respectively.

- (7) a. They tried to cover his error. =>(D)
 b. Iceland-based F-15s would cover the operations.
 =>(E)

Notice that nothing is actually placed or spread over his error in (7a) or the operations in (7b), indicating that these senses are to be distinguished from cover (C).

The following sense, which will be referred to as cover (F), seems to be an extension from cover (E).

- (8) 40 per cent of the people are covered by health insurance. =>(F)

Health insurance protects someone or something, not by a physical means, but by an agreement, which guarantees that money will be paid if there is illness, injury, etc. By focusing on a specialized means of protection, i.e. insurance, rather than protection itself, cover acquires the sense of 'to insure'.

Thus the focus shifts twice in the course of meaning extensions, as shown in (9).

- (9) a.

to place sth over sth	to keep sth safe
-----------------------	------------------

 : (C)
 ↓

- b.

to keep sb/sth safe

 : (E)
- ↓
- c.

to insure	to keep sb/sth safe
-----------	---------------------

 : (F)

Cover (F) is obtained by perspectivizing the implied result of cover (C), i.e. the sense of protection. The focus shifts "forward". But cover (G) is obtained by highlighting the means of protection, i.e. insurance. The focus shifts "backward".

9.2.2. Cover (G)

Now let us turn to the following sense, which will be referred to as cover (G).

- (10) I decided to cover approximately twenty miles a day.
(COBUILD) => (G)

This sense can be paraphrased as 'to go over, travel', so it might be tempting to analyze cover (G) as a GO-verb. Yet cover (G) is more like an INCH-verb than a GO-verb (I follow Jackendoff (1990) in assuming that GO and INCH are two independent functions, which happen to overlap in their application in some instances).

Consider the variety of path functions the verb takes. As Jackendoff (1990) argues, a genuine GO-verb can occur not only with bounded paths (sources and goals) as in (11a), but also with directions as in (11b) and routes as in (11c), where the endpoints are left inexplicit.

- (11) a. John ran into the house.
b. The mouse skittered toward the clock.
c. The train rambled along the river.

(Jackendoff 1983:168)

Cover (G) cannot occur either with directions (12a) or with routes (12b).

- (12) a. *John covered northward.
b. *John covered along the river.

It seems that the postverbal position of *cover* (G) is limited to either the ground or a measured distance like 50 miles, and that the distance denoted is necessarily completely traveled. Hence directions and routes, both of which are not bounded and hence cannot be completely traveled, are incompatible with cover.

Moreover, consideration in terms of lexical relatedness argues against analyzing cover (G) as a GO-verb. Notice that none of the senses of cover thus far has been a GO-verb. If anything, all the event senses of cover are INCH-verbs: Both cover (B) and cover (C) are so analyzed. It is therefore unlikely that of the various senses of cover, cover (G) alone is a GO-verb.

Given that cover (G) is not a GO-verb, where does the sense of 'to travel' come from? I claim that cover (G) is related to cover (B), repeated as (13), via the image-schema transformation (Lakoff 1987).

- (13) Snow covered the ground.

An assembly of entities may be conceptualized, either in terms of its constituent members, i.e. as a multiplex, or as an undifferentiated mass. The image-schema transformation relating mass and multiplex entities, when applied to a linear configuration, links a one-dimensional line and a series of points that constitute a line.

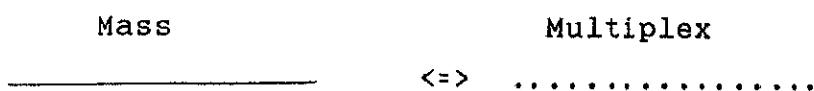

Fig. 3

If the transformation is applied to a plane, it relates a two-dimensional area and an assembly of entities located within the area.

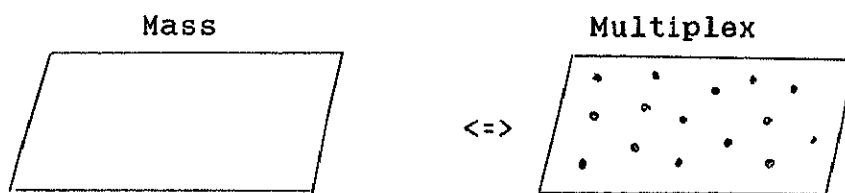

Fig. 4

Now when the points representing the multiplex entity are joined together, a path is formed. It is the image-schema transformation relating mass entities and multiplex paths that characterizes the link between cover (B) and cover (G).

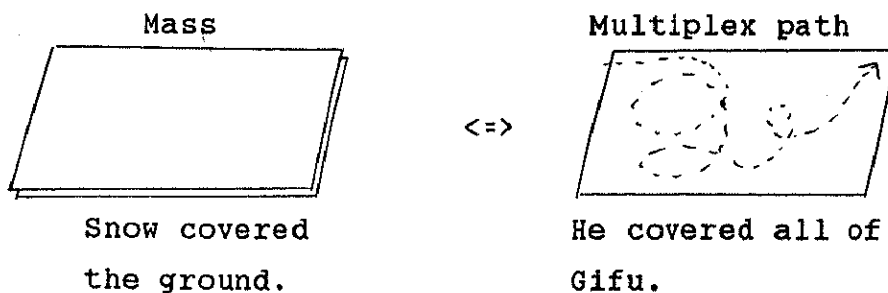

Fig. 5

With cover (B), a two-dimensional object occupies the entire area with its own extension. In contrast, with cover (G) the area is gradually "covered" as a person moves along the path. Either way, the area ends up being completely covered.

At this point, a word is in order about the dimensionality of what is covered. In Fig. 5, I have deliberately chosen an example of cover (G) in which the movement is clearly over

a two-dimensional area. But cover (G) can express a linear movement as well. In fact, expressions like cover the ground or cover 50 miles seem likely to conjure up an image of a one-dimensional movement rather than a two-dimensional one. Fig. 5 should not be taken to indicate that cover (G) necessarily expresses a two-dimensional movement. It just relates mass and multiplex path conceptualizations, independent of dimensionality.

Of course, we have many instances of cover (G) in which a two-dimensional area is traveled. The following sentences clearly express a two-dimensional movement. (14) describes a movement over a circular land area, and (15) refers to a horse ploughing a field.

(14) He covered 50 miles around.

(15) A horse can cover 500 square meters in a day.

In (16), Mantle and Maris are both baseball players. When you are defending, the ground covered cannot be one-dimensional.³

(16) Both are good, daring fielders: Mantle covers more ground; Maris's throwing arm is stronger.

(Brown Corpus)

(17) is a border-line case. It describes a zig-zag movement, which is not strictly a linear movement, although it may be regarded as a variant of a linear movement.

(17) What with continually slicing or pulling his ball into the rough, my uncle covered about twice as much ground as the average golfer in going round a course. (ODCIE)

Thus cover (G) can describe either a one-dimensional movement or a two-dimensional one, depending on the context.⁴

Interestingly enough, the variability of the dimensionality is observed with other senses of cover, which usually refer to a two-dimensional area. (18) clearly describes a one-dimensional extension of snow.

(18) The snow covered the road for 50 miles.

9.2.3. Cover (H)

Let us now turn to another sense of cover. In (19) and (20), cover the ground may be paraphrased as 'to go over a particular topic or area of experience'.

(19) I'll try to cover all the ground in a short speech
of half an hour. (LDOCE)

(20) They managed to cover quite a lot of ground in a
short programme. (OALD)

This sense, which will be referred to as cover (H), is related to cover (G) via the PURPOSEFUL ACTION IS DIRECTED MOTION TO A DESTINATION metaphor (Lakoff 1990:60). One special case of this metaphor, PROGRESS IS DISTANCE MOVED, allows cover (H) to mean 'to make a progress'.

(21) PROGRESS IS DISTANCE MOVED

We've come a long ways.

We've covered lots of ground.

We've made it thus far!

(Lakoff 1990:60)

Cover (H) can express various kinds of actions, one of which is an argument. Lakoff and Johnson (1980) present a detailed analysis of how cover the ground comes to mean what it means in the domain of argument. The knowledge structure of the journey domain includes:

(22) THE PATH OF A JOURNEY IS A SURFACE

We covered a lot of ground.

He's on our trail.

He strayed off the trail.

We went back over the same trail.

(Lakoff and Johnson 1980:90-91)

Putting together AN ARGUMENT IS A JOURNEY and THE PATH OF A JOURNEY IS A SURFACE, we get:

(23) THE PATH OF AN ARGUMENT IS A SURFACE

We have already covered those points.

We have covered a lot of ground in our argument.

Let's go back over the argument again.

You're getting off the subject.

You're really onto something there.

We're well on our way to solving this problem.

(Lakoff and Johnson 1980:91)

Conceivably, other kinds of actions can be similarly explained by means of metaphors.

9.3. The network of cover

It has been shown that various senses of *cover* are systematically related. The relatedness can be summarized as in Fig. 6.

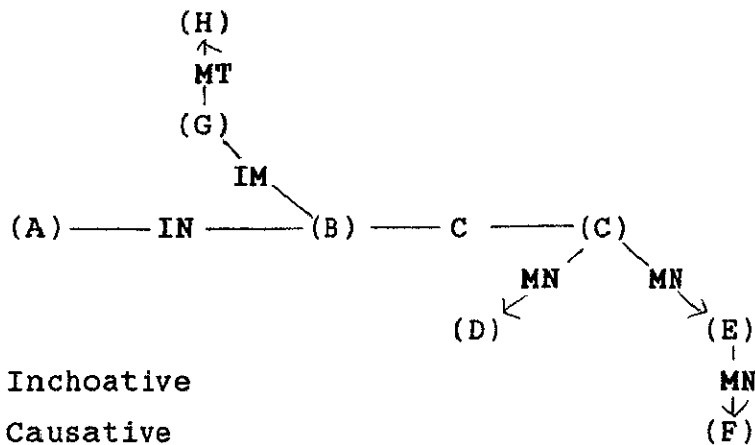

IN: Inchoative
 C: Causative
 IM: Image-schema
 transformation
 MT: Metaphor
 MN: Metonymy

Fig. 6

Cover (G), which is related to cover (B) via an image-schema transformation, is put in the G-network. On the other hand, cover (D) and cover (E), which are related to cover (C) via metonymy, are included in the S-network. Thus we can say that image-schema transformations constitute a G-link.

But we cannot say offhand that metonymy is an S-link. Notice that the locative alternation can fall within the realm of metonymy on a very general understanding of this term. Thus while metaphor in the sense of Lakoff unquestionably falls within the S-network, metonymy divides into those that constitute G-links and those that form S-links.

Notes to Chapter 9

* I'd like to express my deepest gratitude to Lynne Roecklein, who provided me with many insightful observations. Thanks are also due to Barbara Johnston for kindly acting as informant.

1. See Jackendoff (1990: Chapter 6, pp.101-106).
2. Seto (1986, 1994) also develops a theory of metonymy in an extended sense.

3. William Lee has pointed out that (16) involves the sense of 'to protect' as well as that of 'to travel a distance'.

4. William Lee provided me with the following example, which seems to count as a three-dimensional example:

- (i) The security guard covered the first four floors of the building before one o'clock.

Chapter 10
From Intralexical to Interlexical Relations:
Lexical Networks of Verbs with
Up-Down Orientation*

10.0. Introduction

The discussion so far has been concerned with the relationships among the senses of single lexical items, or intralexical relations. This chapter aims to show what lexical network theory has to say about semantic relations between lexical items, or interlexical relations.

The following verbs are supposed to be related by entailment, synonymy, and opposition: rise, raise, lift, drop, and fall. A lexical network approach to these verbs reveals at what level the putative semantic relations actually obtain.

10.1. Rise

10.1.1. G-Network

Let us start with the sense of rise in (1), which will be referred to as rise (A).

(1) The balloon rose.

This sense can be paraphrased as "to go upward". As Gruber (1976) observes, upwardness is a necessary feature.

(2) *The balloon rose down. (Gruber 1976:27)

Jackendoff (1983:184), following Gruber (1976), analyzes rise as lexically incorporating the Path UPWARD and posits the conceptual structure in (3).

(3) [Event GO ([Thing X], [Path UPWARD]]
[Path <Y>]]

The angle brackets around the variable Y, indicating that this argument is optional, convey that rise may appear with or without a PP as in (4).

- (4) a. The balloon rose.
 b. The balloon rose along the cliff.

When Y is not present, only a single argument appears syntactically: the path is totally lexicalized by the verb as in (5a). When it is present, we get the use with a PP: the path given by the verb and that given by the PP combine to form a complex path as in (5b).

- (5) a. [Event GO ([Thing BALLOON], [Path UPWARD])]
 b. [Event GO ([Thing BALLOON], [Path UPWARD
 Path ALONG([CLIFF])])]

Now one characteristic of rise (A) is that the Theme as a whole goes upward. Gruber (1976:29) observes that (6) is "somewhat absurd, implying that John is floating upward".

- (6) John is rising quietly. (Gruber 1976:29)

With this in mind, consider (7).

- (7) a. She rose from her knees. (COBUILD)
 b. Put the dough in a warm place to rise for about an hour. (COBUILD)

In these examples, it is not the entire Theme but only its uppermost surface that bears the UP relation. Thus we have here a distinct sense, referred to as rise (B).

The difference between (A) and (B) is shown in Fig. 1.

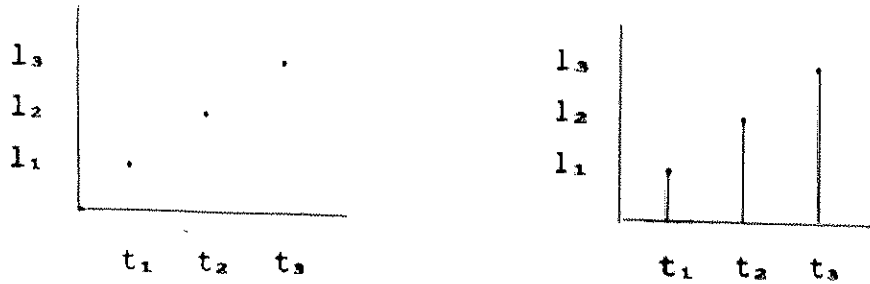

Fig. 1

With rise (A), the Theme's displacement from the horizontal (or some other such reference point) increases with the passage of time, as in Fig. 1. Thus rise (A) can be characterized as a continuous, ordered series of component states as in (8), where M stands for a mover, l a location on the vertical axis, and t a time.

$$(8) \quad \begin{pmatrix} M \\ l_1 \\ t_1 \end{pmatrix} \Rightarrow \begin{pmatrix} M \\ l_2 \\ t_2 \end{pmatrix} \Rightarrow \begin{pmatrix} M \\ l_3 \\ t_3 \end{pmatrix} \dots$$

In contrast, the upper surface undergoes a similar displacement from the horizontal with rise (B). Let M_U stand for the uppermost surface of the mover. Rise (B) is then characterized as a sequence of component states as in (9).

$$(9) \quad \begin{pmatrix} M_U \\ l_1 \\ t_1 \end{pmatrix} \Rightarrow \begin{pmatrix} M_U \\ l_2 \\ t_2 \end{pmatrix} \Rightarrow \begin{pmatrix} M_U \\ l_3 \\ t_3 \end{pmatrix} \dots$$

Consequently rise (A) and rise (B) are captured in terms of a succession of component states as in (10a) and (10b), respectively.

$$(10) \quad \text{a.} \quad \begin{pmatrix} M \\ l_1 \\ t_1 \end{pmatrix} \Rightarrow \begin{pmatrix} M \\ l_{i+1} \\ t_{i+1} \end{pmatrix} \quad \text{b.} \quad \begin{pmatrix} M_U \\ l_1 \\ t_1 \end{pmatrix} \Rightarrow \begin{pmatrix} M_U \\ l_{i+1} \\ t_{i+1} \end{pmatrix}$$

where $l_1 < l_{1+1}$

where $l_1 < l_{1+1}$

(The qualification $l_1 < l_{1+1}$, which appears in both (10a) and (10b), ensures the upwardness of the movement.)

Thus rise (B) is different from rise (A) only with regard to the Theme, suggesting that other parts of the representations are better kept identical. Let us introduce an A-operator, which converts a Thing into part of the Thing. With this machinery, rise (A) and rise (B) are represented in (11a) and (11b), which correspond to (10a) and (10b), respectively.¹

- (11) a. [GO([X], [UPWARD])]
b. [GO([A^{UP} [X]], [UPWARD])]

Besides rise (A) and rise (B), we find an extent sense of rise.

- (12) a. The hills rise steeply.
b. St Paul's rose majestically from the trees.
(COBUILD)

This sense, referred to as rise (C), is represented by means of GO_{EXT}. Thus (12a) receives the representation in (13).

- (13) [GO_{EXT} ([HILLS], [UPWARD])]

As argued in Chapter 4, GO and GO_{EXT} are distinct but related functions, which share a great deal of internal structure.

Thus we have three senses of rise in the Spatial field.

10.1.2. S-Network

10.1.2.1. Extensions of (A)

Rise has a sense paraphrasable as "increase", as exemplified in (14).

(14) a. My income rose last year.

(Lakoff and Johnson 1980:16)

b. Prices rose by more than 10% per annum.

c. The temperature began to rise. (COBUILD)

This sense, rise (D), is clearly related to rise (A) via MORE IS UP; LESS IS DOWN along with LINEAR SCALES ARE PATHS (Lakoff 1990:53).

Closely related to rise (D) is rise (E), as instantiated in (15).

(15) Tension is rising in the street of the capital.

(COBUILD)

This sense, meaning "to become intense", also involves MORE IS UP; LESS IS DOWN. What distinguishes rise (D) from rise (E) is thus whether MORE IS UP is projected onto a numerical scale or not.²

A couple of other senses are similarly accounted for. (16) is an instance of rise (F), which is related to rise (A) via HAPPY IS UP; SAD IS DOWN.

(16) My spirits rose. (Lakoff and Johnson 1980:15)

(17) and (18) instantiate rise (G), which is again related to rise (A), via HIGH STATUS IS UP; LOW STATUS IS DOWN.

(17) She'll rise to the top. (Lakoff and Johnson 1980:16)

(18) Men of his age rose gradually in rank and responsibility with each passing year. (COBUILD)

Rise may mean "to appear" as well.

(19) A fog rose over the valley.

It might appear that this sense, referred to as rise (H), is not distinct from rise (A). However, the distinctness of rise (H) is reflected in syntax. Levin & Rappaport (1995) observe that certain verbs of inherently directed motion may appear in the locative inversion construction when these verbs simply describe appearance on the scene, losing any sense of motion. Rise is one of the verbs they cite:

(20) Out of the trees below them rose a large night bird
with a great flapping of wings.

(Levin and Rappaport 1995:242)

How upward movement is related to the sense of appearance is well documented by Lindner (1982, 1983), who speaks of the experiential basis in the sense of Lakoff and Johnson (1980). We know from our experience that UP paths and postures typically characterize objects which are visible: Objects which are below the line of sight are not visible, but when they move upward they enter the range of perceptual access, thereby becoming visible.

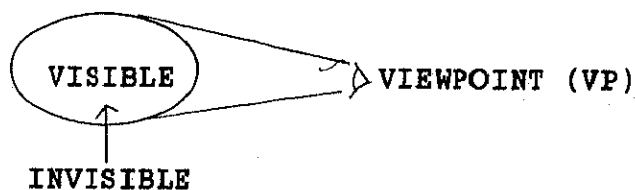

Fig. 2

Thus the relevant conceptualization might be phrased as VISIBLE IS UP; INVISIBLE IS DOWN. Accordingly, the conceptual structure of rise (H) is as in (21):

(21) [GO([X],[TO IN VIEW])]

Now rise may mean "to occur", independent of visual perception, as in (22) and (23).

(22) Murmurs of disapproval rose from the crowd.

(CAMBRIDGE)

(23) A feeling of panic was rising in him. (COBUILD)

This sense, rise (I), is a further extension of rise (H). Rise (I) receives the following representation.³

(24) [GO([X],[TO IN EXISTENCE])]

10.1.2.2. Extensions of (B)

Lakoff and Johnson (1980:15) cite (25) as an instance of the CONSCIOUS IS UP; UNCONSCIOUS IS DOWN metaphor.

(25) He rises early in the morning.

(Lakoff and Johnson 1980:15)

However, simply to say that this sense, rise (J), is a metaphorical extension of rise (A), parallel to rise's (D), (E), and (F), misses an important point. Unlike the extensions of rise (A) seen in the last section, the sense of assuming an upright posture is easily detectable in rise (J), suggesting that rise (J) is related to rise (B), rather than rise (A).

Note further that rise (J) can be paraphrased as "to stop sleeping and get out of bed". That is, rise (J) conveys temporally contiguous events by naming only one portion of those events (i.e. to stand up). Thus rise (J) is related to rise (B) via metonymy, contra Lakoff and Johnson (1980).⁴

The following are treated similarly. The sense exempli-

fied in (26), rise (K), means "to rebel, to revolt".

(26) The settlers rose in revolt. (COBUILD)

Certainly standing up is a prerequisite for starting to fight. Thus the temporally consequent event of revolting is indicated by mentioning the act of standing up.

The following sense, rise (L), is used to describe a situation in which a court of law or parliament stops its work at the end of a day or at the end of its formal session.

(27) The House rose at 10 pm. (OALD⁴)

Here the meeting denoted by the subject NP (the House) metonymically stands for the people taking part in the meeting (i.e. members of the House of Commons). Now when the meeting is over, the people attending it stand up and leave the room. Because of this temporal contiguity, the event of people standing up may metonymically stand for that of people dispersing. Thus rise (L) involves double metonymies.

10.1.2.3. Extensions of (C)

Now let us consider (28).

(28) There's nothing in the play which rises to the level of character analysis. (COBUILD)

This sense, rise (M), clearly involves the GOOD IS UP; BAD IS DOWN metaphor (Lakoff and Johnson 1980). But rise (M) is related to which of the spatial senses? Rise (M) does not describe an Event of something changing its quality, but a State in which something has a good quality. This suggests that rise (M) is related to rise (C), the extent sense, rather than to rise (A) or to rise (B).

The same is true of (29).

(29) The Thames rises in the Cotswold Hill. (OALD*)

This sense, rise (N), describes the source of a river, not repeated events of water flowing. It is probably an extent counterpart of the "come into existence" sense. Thus rise (N) is represented as in (30).

(30) [GO_{Ext} ([THE THAMES], [TO IN EXISTENCE])]

Now the relationships among various senses of rise are summarized as in Fig. 3.

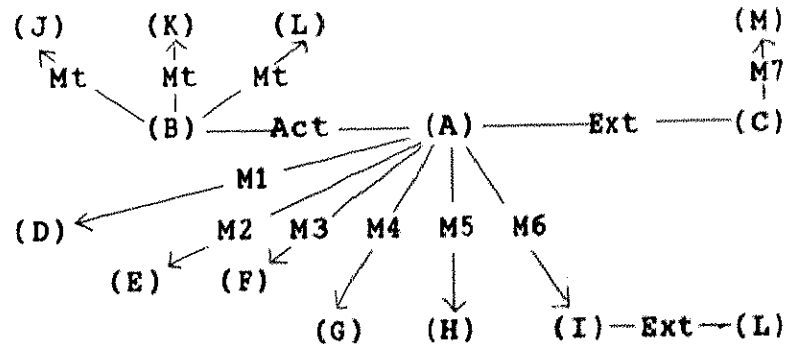

Ext: GO/GO_{Ext} alternation Act: Active zone
 M1: MORE IS UP; LESS IS DOWN
 M2: MORE IS UP; LESS IS DOWN + NUMERICAL SCALE
 M3: HAPPY IS UP; SAD IS DOWN
 M4: HIGH STATUS IS UP; LOW STATUS IS DOWN
 M5: VISIBLE IS UP; INVISIBLE IS DOWN
 M6: EXISTENT IS UP; NON-EXISTENT IS DOWN
 M7: GOOD IS UP; BAD IS DOWN
 Mt: metonymy

Fig. 3

10.2. Raise

10.2.1. G-Network

Let us consider raise next. Jackendoff (1983) posits the

conceptual structure in (31) for raise on the assumption that raise is a causative of rise.

- (31) [Event CAUSE([Thing X],[Event GO([Thing Y],
[
UPWARD
]
<Z>
)])]]

(Jackendoff 1983:184)

Enclosing the variable Z in the angle brackets shows that like rise, raise has two uses in (32), i.e. with and without the PP after the direct object.

- (32) a. Max raised his hand to the ceiling.
 b. Max raised his hand.

Let us refer to this sense as raise (A).

Now recall that rise has a sense (B) in which active zones of the Theme, rather than the entire Theme, move upward. Raise also seems to have a sense making use of active zones. In the following examples, raise means "to move someone or something to an upright position".

- (33) raise a man from his knees (OALD⁴)

- (34) We raised the fence and fixed it in position.
 (OALD⁴)

When raise (B) takes a reflexive as its direct object, the resulting meaning is very close to rise (B).

- (35) Slowly she raised herself to her full height.
 (COBUILD)

It appears that raise (A) and raise (B) exhaust the spatial senses of raise, and that an intransitive sense

cannot be formed through decausativization. Levin and Rappaport (1995) argue that causative verbs can decausativize when the eventualities described come about spontaneously without the external intervention of an agent. But the sense of spontaneous upward movement can be fully expressed by rise, and there seems to be no reason to go to the trouble of decausativizing raise to arrive at a meaning nearly identical with rise.

Yet raise does decausativize, although in a very limited usage, when the resulting meaning is not identical with rise. In the current GB literature, we quite often come across the decausativized sense of raise as in (36).

(36) The NP raises to [NP, CP].

Let us refer to this sense as raise (C). Raise (C) merely expresses upward movement without the intervention of an external causer, and its representation is as in (37).

(37) [GO([X],[UPWARD])]

Here "upward movement" has to be defined over the syntactic tree diagram.

10.2.2. S-Network

Raise has several S-network senses, which metaphors can straightforwardly account for. It has a sense paraphrasable as "to increase", as exemplified in (38).

- (38) a. He raised his offer to \$500. (OALD⁴)
b. raise the temperature to 80 (OALD⁴)

This sense, raise (D), is related to raise (A) via MORE IS UP; LESS IS DOWN together with NUMERICAL SCALES.

We have also a sense, meaning "to make intense", as shown in (39).

- (39) Gregory began to raise his voice in protest.
(COBUILD)

This sense, raise (E), is related to raise (A) via MORE IS UP; LESS IS DOWN.

Raise (F) and raise (G), exemplified in (40) and (41), are related to raise (A) via HAPPY IS UP and HIGH STATUS IS UP, respectively.

- (40) Our little chat has really raised my spirits.
(CAMBRIDGE)

- (41) The president of the company raised me to a managerial position.

Raise (H), exemplified in (42), is related to raise (A) via GOOD IS UP; BAD IS DOWN.

- (42) raise the standard of living

Now recall that upward movement is related to the sense of coming into existence via what might be called EXISTENCE IS UP, as seen in 10.1.2.1. This conceptualization is available for raise as well.

- (43) The announcement raised a cheer/laugh/murmur.
(CAMBRIDGE)

- (44) a. For me it always raises fond memories of broad main streets.
b. His jokes barely raised a smile. (COBUILD)

This sense, meaning "to cause to exist", will be referred to as raise (I).

Raise also has the following sense.

- (45) The book raises many important issues (for our consideration). (OALD⁴)

This sense, raise (J), is also accounted for in terms of an abstract UP region. Rudzka-Ostyn (1988) argues that the up exemplified in (46) indicates that something has reached the hearer's awareness or receptivity.

- (46) a. Alies ... had brought the whole thing up.
b. Your question came up at the meeting.
c. I'll ask the next speaker to take up your suggestion. (Rudzka-Ostyn 1988:539)

That is, the hearer's awareness counts as an abstract region. Consequently, up can be used to convey that a given idea is presented to the hearer for consideration.

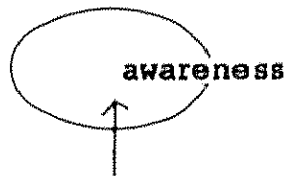

Fig. 4

Rudzka-Ostyn argues that because of this conceptualization, an upward path profiled by raise can be associated with the speaker's conscious attempt to reach the level of the hearer's awareness.⁵

Consider next the following sense, raise (K).

- (47) His children were raised in the Catholic faith.
(COBUILD)

Growth is typically correlated with increase in vertical dimension. Thus the relevant metaphor might be phrased as

GROWTH IS UP, which accounts for the following expressions as well.

- (48) a. I brought up two children alone.
 b. I had grown up in the district.
 c. Geraldo has adopted and reared four children.
 (COBUILD)

Raise (K) is related to raise (B) via this metaphor.

Now the overall network of raise is described as Fig. 5.

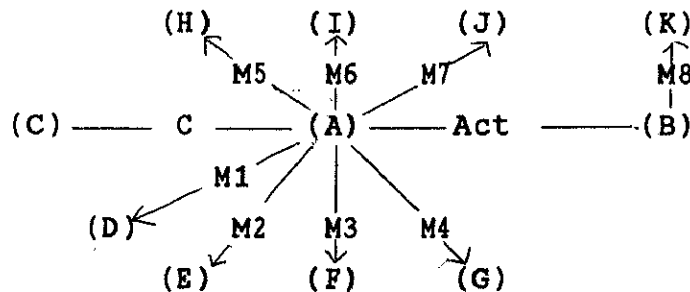

- Act: Active zone C: causative
 M1: MORE IS UP; LESS IS DOWN
 M2: MORE IS UP; LESS IS DOWN + NUMERICAL SCALES
 M3: HAPPY IS UP; SAD IS DOWN
 M4: HIGH STATUS IS UP; LOW STATUS IS DOWN
 M5: GOOD IS UP; BAD IS DOWN
 M6: EXISTENT IS UP; NON-EXISTENT IS DOWN
 M7: BEING IN AWARENESS IS UP
 M8: GROWTH IS UP

Fig. 5

10.3. Lift

Next let us turn to lift, which is similar to, but not entirely the same as, raise.

10.3.1. G-Network

Lift, like raise, can mean "to move something upward" as

in (49).

(49) He lifted the glass to his mouth. (COBUILD)

Let us refer to this sense as lift (A).

While seemingly very similar, lift (A) and raise (A) are not strictly identical. With lift (A), an object may move downward following the initial upward detachment.

(50) He lifted the box carefully down from the shelf.
(CAMBRIDGE)

This is not possible with raise (A).⁶

(51) *He raised the box carefully down from the shelf.

Next, the sense of assuming an upright position, lift (B), is available as well.

(52) She lifted herself to her feet.

Lift seems to decausativize more easily than raise. The following example of lift (C) conveys upward movement of mist without any intervention of an external agent.

(53) The morning mist is lifting. (COBUILD)

Lift also has an extent sense, lift (D), corresponding to lift (C).

(54) The tower lifts above the surrounding mountains.

10.3.2. S-Network

Lift has counterparts for most of the S-network senses of

raise. (55) and (56) exemplify lift (E) and lift (F), which are related to lift (A) via MORE IS UP coupled with NUMERICAL SCALES and MORE IS UP, respectively.

(55) They expect that this will lift the rate of inflation back to 13 percent. (COBUILD)

(56) She lifted her voice for her child to hear.
(COBUILD)

Lift (G) is related to lift (A) via HAPPY IS UP.

(57) These delightful children lifted my spirits with their laughter. (COBUILD)

Lift (H) is related to lift (A) via HIGH STATUS IS UP.

(58) The boss lifted me to a managerial position.

Lift (I) is related to lift (A) via GOOD IS UP.

(59) They lifted the standard of living.

One point that differentiates lift from raise is that it has a sense, exemplified in (60), paraphrasable as "to end", which is not available for raise.

(60) a. The restrictions on water usage have been lifted now that the river levels are normal.

b. At last they've lifted the ban on jeans at the club. (CAMBRIDGE)

(61) *raise a ban/restrictions

Let us refer to this sense as lift (J). The emergence of this sense is quite natural. When we focus upon the moved entity, lifting something means moving it to a higher position. But

when we focus upon the location, lifting something means removing it.⁷

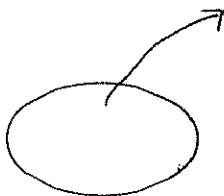

Fig. 6

The sense of removal thus obtained acquires independent status, losing the sense of upward movement. It is further extended by regarding some states as abstract locations. Lift may mean "to steal" as in (62) or "to plagiarize" as in (63).

- (62) a. They break into steel filing cabinets, open cupboards, or lift a briefcase from a locked car or office. (COBUILD)
b. Those radios were so cheap I'm sure they'd been lifted. (CAMBRIDGE)
- (63) Many of his ideas were lifted from other authors. (OALD⁴)

This sense, lift (K), is obtained by construing one's possession space as an abstract location.⁶

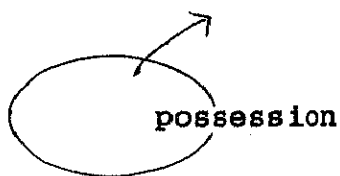

Fig. 7

Lift (J) has an intransitive counterpart, as exemplified in (64).

- (64) His moodiness seemed to have lifted. (COBUILD)

This sense, lift (L), is an extension of lift (C) as well as

being the decausativized version of lift (J).

Finally, consider the following.

(65) There is a restriction on the number of passengers
foreign airlines can lift from the island.

(COBUILD)

Here, the act of lifting people out of the island metonymi-
cally stands for the whole process of transporting them by
plane.



Fig. 8

This sense will be referred to as lift (M).

Now the network of lift is described as in Fig. 9.

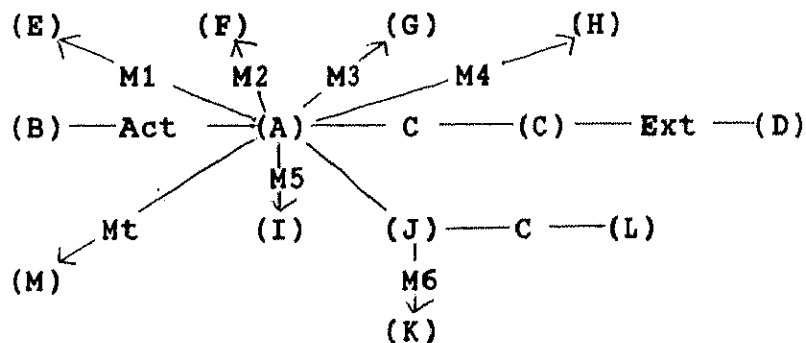

Act: Active zone

Ext: GO/GO_{Ext} alternation

C: Causative

Mt: Metonymy

M1: MORE IS UP; LESS IS DOWN + NUMERICAL SCALE

M2: MORE IS UP; LESS IS DOWN

M3: HAPPY IS UP; SAD IS DOWN

M4: HIGH STATUS IS UP; LOW STATUS IS DOWN

M5: GOOD IS UP; BAD IS DOWN

M6: BEING POSSESSED IS LOCATION

Fig. 9

10.4. Drop

10.4.1. G-Network

Next let us turn to drop. Drop has an intransitive sense drop (A) as in (66a) and its causative, transitive counterpart drop (B) as in (66b).

- (66) a. The stone dropped.
b. He dropped the stone.

These senses can be analyzed as incorporating the Path DOWNWARD.

- (67) a. [GO([X],[DOWNWARD])]
b. [LET([Y],[GO([X],[DOWNWARD])])]

While with drop (A) and drop (B) the Theme as a whole undergoes downward movement, only the topmost part of the Theme moves downward in (68).

- (68) She dropped into a chair.

This sense, drop (C), is analyzed as involving an A-operator, parallel to rise (B).

- (69) [GO([A^{up} [X]],[DOWNWARD])]

Drop also has an extent sense, drop (D).

- (70) The ocean floor dropped steeply fifty yards from the shore. (COBUILD)

10.4.2. S-Network

10.4.2.1. Extensions of (A)

Previously discussed metaphors can account for several

senses of drop. Drop (E), exemplified in (71), is related to drop (A) via LESS IS DOWN together with NUMERICAL SCALES.

(71) The temperature of their bodies dropped ten degrees. (COBUILD)

Drop (F) is related to drop (A) via LESS IS DOWN.

(72) Bill's voice dropped when he saw his father on the other side of the room. (COBUILD)

And drop (G) is related to drop (A) via LOW STATUS IS DOWN.

(73) He has dropped to fifth position. (COBUILD)

10.4.2.2. Extensions of (B)

Drop (H) is related to drop (B) via MORE IS UP; LESS IS DOWN.

(74) They dropped their voices as they entered the church. (COBUILD)

Drop (H) is the causative of drop (F) as well.

Interestingly enough, drop may mean "to abandon, to give up" as in (75) and (76).

(75) Most of the charges were dropped when Brown pleaded guilty. (COBUILD)

(76) She's been dropped from the team because of injury.
(OALD*)

The emergence of this sense, drop (I), is explained similarly to the case of lift. Dropping something means letting that something go from its former location, the sense of

abandonment thus obtained acquiring independent status.

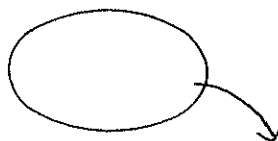

Fig. 10

When one's possessional space serves as an abstract location, the meaning becomes "to lose", drop (J), as in (77).

(77) I hear they've dropped over ten thousand on the deal. (OALD⁴)

Next, in (78) dropping a person somewhere means taking that person there and leaving them there.

(78) Shall I drop you (off) at the station? (CAMBRIDGE)

This sense, drop (K), is accounted for in terms of a metonymy: The act of dropping a person out of a car metonymically stands for the whole process.

Drop (L), exemplified in (79) and (80), refers to utterings.

(79) She dropped (him) a hint that they would like to come to the wedding. (CAMBRIDGE)

(80) It's up to you to drop a word of warning in her ear. (COBUILD)

Drop (L) is related to drop (B) via that part of the conduit metaphor (Reddy 1979) which states that ideas are ejected by speaking or writing into an external "idea space".

This conceptualization consists of two metaphors: On the one hand, the speaker is conceptualized as a container for ideas, with a bounding surface and an in-out orientation,

viz. PEOPLE ARE CONTAINERS. On the other, ideas are regarded as moving objects, which come out of the speaker. Hence IDEAS ARE OBJECTS. Because of these metaphors, dropping a word comes to mean what it means.

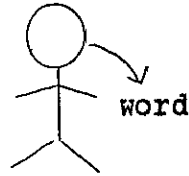

Fig. 11

10.4.2.3. Extension of (C)

Finally, consider (81).

(81) He dropped off to sleep.

(Lakoff and Johnson 1980:15)

Lakoff and Johnson (1980) cite (81) as an instance of the CONSCIOUS IS UP; UNCONSCIOUS IS DOWN metaphor. Yet this sense, drop (M), involves the sense of lowering oneself, suggesting its relatedness with drop (C). Thus drop (M) is to be analyzed as metonymically conveying the sense of lowering oneself and falling asleep.

Now the overall network of drop is as in Fig. 12.

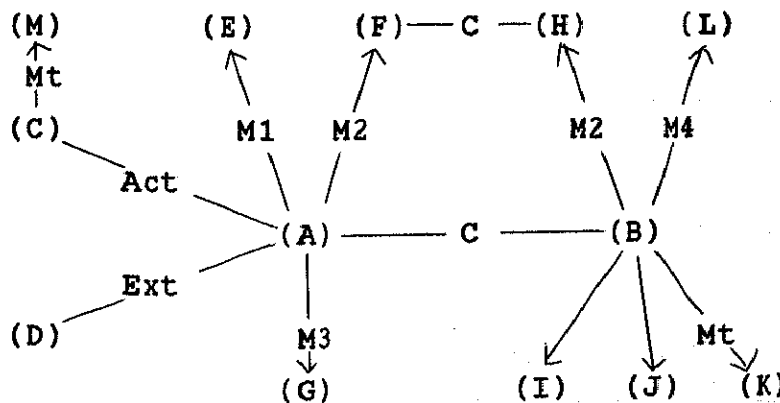

Act: Active zone Ext: GO/GO_{Ext}. alternation
M1: MORE IS UP; LESS IS DOWN + NUMERICAL SCALE

M2: MORE IS UP; LESS IS DOWN
M3: HIGH STATUS IS UP; LOW STATUS IS DOWN
M4: PEOPLE ARE CONTAINERS + IDEAS ARE OBJECTS
Mt: metonymy

Fig. 12

10.5. Fall

10.5.1. G-Network

Finally, let us turn to fall. The most typical sense of fall is exemplified in (82).

(82) The china fell from her hand. (COBUILD)

This sense, fall (A), is represented in (83).

(83) [GO([X],[DOWNWARD])]

While the entire Theme moves downward with fall (A), the uppermost part does so with fall (B), exemplified in (84).

(84) She lost her balance and would have fallen if she hadn't supported herself. (COBUILD)

Fall also has an extent sense.

(85) His wavy, reddish hair falls to his shoulders.
(COBUILD)

10.5.2. S-Network

Fall has counterparts for several of the S-network senses of drop. Fall (D), exemplified in (86), is related to fall (A) via LESS IS DOWN along with NUMERICAL SCALES.

(86) The value of the dollar has fallen. (COBUILD)

Fall (E) is related to fall (A) via LESS IS DOWN.

(87) Her voice fell as they entered the room. (OALD*)

Fall (F) is related to fall (A) via SAD IS DOWN.

(88) Her spirits fell at the bad news. (OALD*)

Fall (G) is related to fall (A) via PEOPLE ARE CONTAINERS plus IDEAS ARE OBJECTS.

(89) What words had fallen from the lips of Mr Smythe?
(COBUILD)

What's unique about fall is the following sense, fall (H).

- (90) a. He fell silent.
b. Has she fallen ill again? (OALD*)

This sense, paraphrasable as "to become", receives the representation in (91).

(91) [GO_{ident} ([X],[TO IN Y])]

This sense can be further divided into subsenses based on the metaphor which specifies what kind of state X goes into. Thus, (92a) and (92b) are instances of UNCONSCIOUS IS DOWN and SICKNESS IS DOWN, respectively.

- (92) a. He fell asleep.
b. He fell ill.

While the discussion up to this point has been exclusive-

ly concerned with extensions of fall (A), the following seems to be an instance of extension from fall (B).

(93) The regime had fallen. (COBUILD)

This sense, fall (I), can be paraphrased as "to topple, to collapse", suggesting its relatedness with fall (B). The relevant metaphor may be phrased as ABSTRACT IS CONCRETE.⁹

The network of fall is described as in Fig. 13.

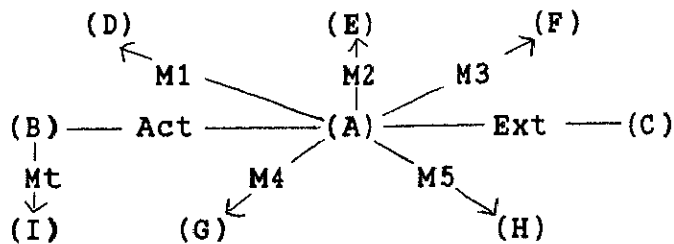

- M1: MORE IS UP; LESS IS DOWN + NUMERICAL SCALE
- M2: MORE IS UP; LESS IS DOWN
- M3: HAPPY IS UP; SAD IS DOWN
- M4: PEOPLE ARE CONTAINERS + IDEAS ARE OBJECTS
- M5: PROPERTIES ARE LOCATIONS
- M6: ABSTRACT IS CONCRETE

Fig. 13

10.6. Entailment, Synonymy, and Opposition

Since the five verbs discussed so far are bound together by such relations as synonymy and entailment, they provide an opportunity to examine the oft-repeated claim that a semantic theory should account for these relationships.

Jackendoff (1990) argues that the entailment relationships between the members of the causative-noncaustive pairs such as those in (94) straightforwardly follow from his lexical decomposition theory.

(94) a. X killed Y -> Y died

- b. X lifted Y -> Y rose
 - c. X gave Z to Y -> Y received Z
 - d. X persuaded Y that P -> Y came to believe that P
- (Jackendoff 1990:39)

The left-hand side verbs are all causatives, e.g. to kill is to cause to die, to lift is to cause to rise, etc. and all the inferences are instances of a general schema in (95).

(95) [CAUSE ([X],[Y])] -> Y

Jackendoff is right in claiming that inferential properties are to be captured in terms of semantic functions, rather than meaning postulates. Yet what seems to be lacking in his argument is the recognition that a lexical item may have more than one sense and entailment relations obtain between senses, not between lexical items.

To illustrate, consider the entailment relation between lift and rise in (94b). Even in the spatial domain this inference pattern is of limited applicability. The entailment relation obtains between lift (A) and rise (A) or between lift (B) and rise (B), but not between lift (A) and rise (B) or between lift (B) and rise (C).

- (96) a. He lifted the glass to his mouth. => lift (A)
- b. She rose from her knees. => rise (B)
- (97) a. She lifted herself to her feet. => lift (B)
- b. The hills rise steeply. => rise (C)

The same is true of other semantic relations. Thus while raise and lift appear to be roughly synonymous, not everything that can be raised can be lifted as well. (98a) and (98b) mean quite different things, and (99a) does not have its counterpart in (99b).

- (98) a. raise children
b. lift children
(99) a. lift sanctions
b. *raise sanctions

Rise and fall are sometimes opposites, but not always so. Rise cannot mean the opposite of (100). Nor can fall indicate the opposite of (101).

- (100) a. Not a word fell from his lips. (OALD*)
b. He fell silent.
(101) The House rose at 10 pm.

Interestingly enough, lift and drop, which appear to be opposites, may convey nearly identical meanings. Both can convey that something goes out of existence as in (102).

- (102) a. lift sanctions
b. drop sanctions

Moreover, even the same verb may express two meanings which are nearly opposites. One may drop a word when starting a conversation, but one drops the subject to stop discussing.

Thus semantic relations like synonymy and entailment are to be defined between senses. This consideration once again argues for the lexical network theory, where various senses of a single word are explicitly differentiated.¹⁰

Notes to Chapter 10

* I'd like to thank the following people for kindly acting as informants: Lynne Roecklein, William Lee and John Russell. Special thanks go to William Lee, who made comments on an earlier version of this paper and suggested extensive stylistic improvements.

1. It is not uncommon for only a subportion of an entity to occupy a path. Lindner (1983:115) calls the relevant subportion of an entity the ACTIVE ZONE, following Langacker (1984, 1987), and cites many examples of verb-particle constructions. Thus the tops of entities are active zones in (i) and (ii).

(i) a. The broth boiled/bubbled up (and out of the pot).

b. The fire flared up.

(ii) a. Draw yourself up to full height.

b. Lift up your head — straighten up.

(Linder 1983:115)

Other portions besides tops may serve as the active zone; the edge in (iii) and the bottom in (iv).

(iii) a. Flip up the lever.

b. Jack up the car. (Lindner 1983:116)

(iv) a. Roll up your sleeves.

b. Jack up/turn up the hem. (Lindner 1983:117)

Active zones can be regarded as a kind of metonymy. But in the text I will use the term "Active zone", partly in respect for Langacker, and partly to distinguish it from other subtypes of metonymy.

2. Notice that the scale meant by the LINEAR SCALES ARE PATHS metaphor is not limited to a numerical scale, but applies to non-numerical scales as well.

3. Konishi (1980) observes that (i) may mean either that the wind came or that the wind became stronger.

(i) The wind rose.

In the current context, this means that (i) is ambiguous between rise (I) and rise (E).

4. See Taylor (1989: Ch. 7) and Seto (1986, 1995) for this extended notion of metonymy.

5. This also explains why raise (J) can be paraphrased with bring up.

6. William Lee (personal communication) has provided me with the following sentence:

- (1) The desktop/table top was easy to raise, but hard to lift.

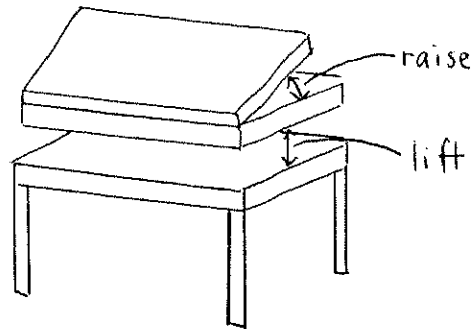

7. Or it may be more appropriate to say that the sense of removal is obtained by perspectivizing an implication, as is the case of cover in 9.2.1.

8. Note that the sense of upward movement is hardly present in lift (K), which allows lift to express a meaning related to possession (Recall that the possessional space has no vertical dimension, as argued in Chapter 6). Lift (K) does not assert an upward movement in the possession space, but simply a removal of something from the possession space.

9. I am indebted to William Lee for this characterization.

10. In contrast, these semantic relations cannot be dealt with properly by Jackendoff's (1990) lexical abbreviation analysis, which fails to give due attention to the differentiation of the multiple senses.

Summary and Conclusion

1. G-network/S-network

Chapter I began with the following questions:

- (1) Is a single lexical entry sufficient to accommodate multiple senses of a verb?
- (2) How should the relatedness among the senses be captured?

The answer to the first question was in the negative, and that to the second was "in terms of a lexical network".

Having gone through exploration into G- and S-network links and several case studies, we are now in a position to confirm these answers. Our discussion has revealed that the following phenomena fall into G- and S-networks:

G-network

complement alternation	(1.2.1.)
causative pair	(1.2.1.)
incorporation	(1.2.1.)
spatial resultative	(1.2.1.)
GO/GO _{EXT} alternation	(7.1.2.)
reflexive path	(8.1.3.)
profile shift	(8.2.1.2.)
inchoative alternation	(9.2.1.)
image-schema transformation	(9.2.2.)
active zone	(10.1.1.)

S-network

metaphor	
thematic relations	
metonymy (=perspectivization of an implication)	(9.2.1.)

(The righthand number indicates the section where the phenomenon is discussed.)

While Jackendoff (1990) proposes a couple of abbreviatory conventions that permit certain alternations to be expressed with a single lexical entry, the notational trick looks

plausible only for a couple of phenomena, like causative alternation and inchoative alternation. Most of the relationships obtaining between the senses resist similar formal treatment.

2. L-meaning/P-meaning

A number of findings revealed in the course of discussion have important consequences for the theory of lexicon. Of particular significance is the form-meaning correspondence model arrived at in chapter 2, which crucially rests upon the L-meaning/P-meaning distinction.

An implication of the L-meaning/P-meaning distinction is that not every aspect of meaning can be formally represented, which in turn suggests the need for an integrated theory making use of pictorial representations as well as conceptual argument structures. Several other links like image-schematic transformation easily find their places in this integrated theory.

As Norvig and Lakoff (1987) observe, it is the source domain semantic roles that are relevant to the syntax. Thus the form-meaning correspondence model, essentially the same as construction grammar approach (Goldberg 1992a, 1992b), seems to be able to account for the mapping of semantic arguments to syntactic positions in non-spatial domains as well.

3. Residual Problems

3.1. Weaknesses of Network Analyses

As has been pointed out in the literature, lexical network analyses suffer from certain weaknesses, like (a) a lack of clear methodological principles for the identification of distinct senses, (b) a vagueness about whether the distinction is semantic (different meanings of the word) or referential (different contextualizations of a single meaning), and (c) an uncertainty about what the cognitive

interpretation of the networks should be (Sandra and Rice (1995), Vandeloise (1990), among others).

The lexical network analysis proposed in this dissertation is not exempt from these charges. Thus in chapter 1 I argued that the distinctions among the senses are called for because different senses have different thematic properties, but the distinctions in light of thematic properties alone do not always match those native speakers of English feel intuitively.

These problems inherent in network analyses remain to be addressed.

3.2. Coverage

I could not include discussion of psych-verbs in this dissertation. It seems that the psychological domain is characterized by more complex sets of metaphors than the three non-spatial domains investigated in chapter 6 (temporal, possessional, and identificational), and that psych-verbs need a story of their own (See Kovecses 1990). Also, this dissertation almost exclusively deals with verbs which are basically spatial, and not verbs which are basically non-spatial. These verbs are topics for future research.

References

- Amagasaki, A. (1990) Kotoba-to Shintai (Language and Body). Tokyo: Keiso shobo.
- Anderson, J. (1987) "Case Grammar and the Localist Hypothesis," in René Dirven and Günter Radden (eds.), Concepts of Case, 103-121. Tübingen: Narr.
- Anderson, S. (1971) "On the Role of Deep Structure in Semantic Interpretation," Foundations of Language 7, 387-396.
- Bennett, D. (1975) Spatial and Temporal Uses of English Prepositions: An Essay in Stratificational Semantics. London: Longman.
- Binnick, R. (1968) "On the Nature of the 'Lexical Item'," CLS 4, 1-13.
- Bresnan, J. (1979) Theory of Complementation in English Syntax. New York: Garland.
- Brugman, C. (1988) The Story of Over: Polysemy, Semantics and the Structure of the Lexicon. New York: Garland.
- Brugman, C. (1990) "What is the Invariance Hypothesis?" Cognitive Linguistics 1, 257-266.
- Buck, R. A. (1993) "Affectedness and Other Semantic Properties of English Denominal Locative Verbs," American Speech 68, 139-160.
- Carrier, J. and J. Randall. (1992) "The Argument Structure and Syntactic Structure of Resultatives," Linguistic Inquiry 23:2, 173-234.
- Chomsky, N. (1981) Lectures on Government and Binding. Dordrecht: Foris.
- Chomsky, N. (1986) Knowledge of Language: Its Nature, Origin, and Use. New York: Praeger.
- Clark, H. (1973) "Space, Time, Semantics, and the Child," in T. E. Moore, (ed.) Cognitive Development and the Acquisition of Language. 27-64. New York: Academic Press.
- Clark, E. V., and H. H. Clark. (1979) "When Nouns Surface as Verbs," Language 55, 767-811.
- Comrie, B. (1985) Tense. Cambridge: Cambridge University Press.
- Dowty, D. (1991) "Thematic Proto-Roles and Argument Selection," Language 67:3, 547-619.
- Endo, Y. (1986) "A Constraint on English Activo-Passives," Tsukuba English Studies 5, 107-122.
- Fillmore, C. (1968) "Lexical Entries for Verbs," Foundations of Language 4, 373-393.
- Fillmore, C. (1968) "The Case for Case," in E. Bach and R.T. Harms (eds.) Universals in Linguistic Theory. Holt, Rinehart, and Winston.

- New York, 1-88.
- Fillmore, C. (1970) "The Grammar of Hitting and Breaking," in R.A. Jacobs and P.S. Rosenbaum (eds.) Readings in English Transformational Grammar. Waltham, Mass.: Ginn. 120-134.
- Fillmore, C. (1971) "Types of Lexical Information," in D. Steinberg and L. Jakobovits (eds.) Semantics. Cambridge: Cambridge University Press, 109-137.
- Fillmore, C. (1977) "Topics in Lexical Semantics," in R. W. Cole, (ed.) Current Issues in Linguistic Theory. Bloomington, London: Indiana University Press, 76-138.
- Fillmore, C. and B. Atkins. (1992) "Toward a Frame-Based Lexicon: The Semantics of RISK and its Neighbors," in Lehrer, A. and E. F. Kittay (eds.) Frames, Fields, and Contrasts: New Essays in Semantic and Lexical Organization. Lawrence Erlbaum Associates: Hillsdale, New Jersey.
- Fraser, B. (1971) "A Note on the Spray Paint Cases," Linguistic Inquiry 2, 604-607.
- Goldberg, A. (1992a) "The Inherent Semantics of Argument Structure: The Case of the English Ditransitive Construction," Cognitive Linguistics 3:1, 37-74.
- Goldberg, A. (1992b) Argument Structure Constructions. Ph.D. diss., University of California, Berkeley.
- Green, G. (1974) Semantics and Syntactic Regularity. Bloomington: Indiana University Press.
- Gropen, J, S. Pinker, M. Hollander, R. Goldberg, and R. Wilson. (1989) "The Learnability and Acquisition of the Dative Alternation in English," Language 65, 203-257.
- Gruber, J. (1976) Lexical Structures in Syntax and Semantics. Amsterdam: North-Holland.
- Grunau, J. (1985) "Towards a Systematic Theory of the Semantic Role Inventory," CLS 21, 144-159.
- Hale, K. and J. Keyser. (1986) "Some Transitivity Alternation in English," Lexicon Project Working Papers 7. Center for Cognitive Science, Massachusetts Institute of Technology, Cambridge.
- Hale, K. and J. Keyser. (1987) "A View from the Middle," Lexicon Project Working Papers 10. Center for Cognitive Science, Massachusetts Institute of Technology, Cambridge.
- Hawkins, B. (1984) The Semantics of English Spatial Prepositions. Ph.D.

- diss., University of California, San Diego.
- Honda, A. (1992) "Generalized Subjectification," ms., Tokyo University.
- Inagaki, D. (1989) "On the Locative Alternation," Tsukuba English Studies 8, 205-236.
- Itoh, T. (1981) "The Lexicalist Hypothesis Revisited," Linguistic Research 1, 33-63.
- Iwata, S. (1988) "Cross-Field Generalization: Conceptual Structures for Strike and Impress," English Linguistics 5, 111-129.
- Iwata, S. (1989) "Multiple Conceptual Structures of a Single Verb: The Case of Strike," Tsukuba English Studies 8, 179-203.
- Iwata, S. (1990) "On Jackendoff's Conceptual Structure," Tsukuba English Studies 9, 135-168.
- Iwata, S. (1991) "Lexical Relatedness and Conceptual Structure: The Case of Pass," Tsukuba English Studies 10, 111-138.
- Iwata, S. (1994) "Metaphor to shudai-kankei (Metaphor and Thematic Relations)," HELICON 3, 59-77. Department of English, Faculty of General Education, Gifu University.
- Iwata, S. (1995a) "Extending: A Study in Lexical Network Theory," Bulletin of the Faculty of General Education 31, 155-167. Gifu University.
- Iwata, S. (1995b) "Invariance Again: What is Preserved in a Metaphorical Mapping?" English Linguistics 12, 173-196.
- Iwata, S. et al. (1987) "Adjectival Passive Revisited," Tsukuba English Studies 6, 99-130.
- Jackendoff, R. (1976) "Toward an Explanatory Semantic Representation," Linguistic Inquiry 7, 89-150.
- Jackendoff, R. (1979) "How to Keep Ninety from Rising," Linguistic Inquiry 10, 172-177.
- Jackendoff, R. (1983) Semantics and Cognition. Cambridge: MIT Press.
- Jackendoff, R. (1987a) Consciousness and the Computational Mind. Cambridge: MIT Press.
- Jackendoff, R. (1987b) "The Status of Thematic Relations in Linguistic Theory," Linguistic Inquiry 18, 369-411.
- Jackendoff, R. (1990) Semantic Structures. Cambridge: MIT Press.
- Jackendoff, R. (1992) Languages of the Mind. Cambridge: MIT Press.
- Jackendoff, R. and D. Aaron (1991) "Review of Lakoff and Turner (1989)," Language 67, 320-338.
- Jeffries, L. and P. Willis. (1984) "A Return to the Spray Paint Issues,"

- Journal of Pragmatics 8, 715-729.
- Johnson, M. (1987) The Body in the Mind: The Bodily Basis of Meaning, Imagination, and Reason. Chicago: The University of Chicago Press.
- Konishi, T. (ed.) (1980) Eigo-kihon-doushi-jiten (A Dictionary of English Word Grammar on Verbs). Tokyo: Taishukan.
- Kovecses, Z. (1990) Emotion Concepts. New York: Springer-Verlag.
- Kunihiro, T. (1970) Imi-no Shosou (Aspects of Meaning). Tokyo: Sanseido.
- Lakoff, G. (1987) Women, Fire, and Dangerous Things: What Categories Reveal about the Mind. Chicago: University of Chicago Press.
- Lakoff, G. (1990) "The Invariance Hypothesis: Is Abstract Reason Based on Image-Schemas?" Cognitive Linguistics 1, 39-74.
- Lakoff, G. (1992) "The Contemporary Theory of Metaphor," in A. Ortony, (ed.) Metaphor and Thought. (2nd edition) 202-251. Cambridge: Cambridge University Press.
- Lakoff, G. (1993) "The Syntax of Metaphorical Semantic Roles," in J. Pustejovsky, (ed.) Semantics and the Lexicon. 27-36. Kluwer Academic Publishers.
- Lakoff, G. & M. Johnson. (1980) Metaphors We Live by. Chicago: University of Chicago Press.
- Lakoff, G. & M. Turner. (1989) More Than Cool Reason: A Field Guide to Poetic Metaphor. Chicago: University of Chicago Press.
- Langacker, R. (1984) "Active Zones," BLS 10, 172-188.
- Langacker, R. (1986) "An Introduction to Cognitive Grammar," Cognitive Science 10, 1-40.
- Langacker, R. (1986) "Abstract Motion," BLS 12, 455-471.
- Langacker, R. (1987a) Foundations of Cognitive Grammar, Vol.1. Theoretical Prerequisites. Stanford: Stanford University Press.
- Langacker, R. (1987b) "Nouns and Verbs," Language 63, 53-94.
- Langacker, R. (1990) "Subjectification," Cognitive Linguistics 1, 5-38.
- Langacker, R. (1991) Foundations of Cognitive Grammar, Vol.2. Descriptive Applications. Stanford: Stanford University Press.
- Lawler, J. (1989) "Lexical Semantics in the Commercial Transaction Frame: Value, Worth, Cost, and Price," Studies in Language 13:2, 381-404.
- Levin, B. (1991) "Building a Lexicon: The Contribution of Linguistic Theory," International Journal of Lexicography 4:3, 205-226.
- Levin, B. (1993) English Verb Classes and Alternations. Chicago: Univer-

- sity of Chicago Press.
- Levin, B. and T. Rapoport. (1988) "Lexical Subordination," CLS 24, 275-289.
- Levin, B. and M. H. Rappaport. (1986) "The Formation of Adjectival Passives," Linguistic Inquiry 17, 623-61.
- Levin, B. and M. H. Rappaport. (1991) "Wiping the Slate Clean: A Lexical Semantic Exploration," Cognition 41, 123-151.
- Levin, B. and M. H. Rappaport. (1994) "A Preliminary Analysis of Causative Verbs in English," Lingua 92, 35-77.
- Levin, B. and M. H. Rappaport. (1995) Unaccusativity: At the Syntax-Lexical Semantics Interface. Cambridge: MIT Press.
- Lindner, S. (1981) A Lexico-Semantic Analysis of Verb-Particle Constructions with Up and Out. Ph.D. diss., University of California, San Diego.
- Lindner, S. (1982) "What Goes Up Doesn't Necessarily Come Down: The Ins and Outs of Opposites," CLS 18, 305-323.
- Marantz, A. (1992) "The Way-Construction and the Semantics of Direct Arguments in English: A Reply to Jackendoff," in T. Stowell and E. Wehrli (eds.) Syntax and the Lexicon, 179-188. Syntax and Semantics 26. New York: Academic Press.
- Miller, G. and P. Johnson-Laird. (1976) Language and Perception. Cambridge: Harvard University Press.
- Mittwoch, A. (1990) "On the Distribution of Bare Infinitive Complements in English," Journal of Linguistics 26, 103-131.
- Murata, Y. (1982) Kinou eibunpou (Functional English Grammar). Tokyo: Taishukan.
- Nakau, M. (1986) "Imiron-no genri (20-24)," Eigo Seinen CXXXI.
- Nakau, M. (1994) Ninchi-Imiron-No Genri (Principles of Cognitive Semantics). Tokyo: Taishukan.
- Norvig, P. and G. Lakoff. (1987) "Taking: A Study in Lexical Network Theory," BLS 13, 195-205.
- Oka, T. (1986) "Inherent Case," Tsukuba English Studies 5, 123-166.
- Pinker, S. (1989) Learnability and Cognition: The Acquisition of Argument Structure. Cambridge: MIT Press.
- Pittman, G. A. (1965) Activating Advanced English Vocabulary. London: Longman.
- Postal, P. (1974) On Raising. Cambridge, MA: MIT Press.
- Rappaport, M. and B. Levin. (1988) "What to Do with Theta-Roles," in M.

- Wilkins (ed.) Thematic Relations, 7-36. Syntax and Semantics 21. New York: Academic Press.
- Rudzka-Ostyn, B. (1988) "Semantic Extensions into the Domain of Verbal Communication," in Rudzka-Ostyn, B. (ed.) Topics in Cognitive Linguistics. 507-553. John Benjamins.
- Rudzka-Ostyn, B. (1989) "Prototypes, Schemas, and Cross-Category Correspondences: The Case of Ask," Linguistics 27, 613-61.
- Ruhl, C. (1989) On Monosemy: A Study in Linguistic Semantics. State University of New York Press, Albany.
- Sandra, D. and S. Rice. (1995) "Network Analyses of Prepositional Meaning: Mirroring whose Mind -- the Linguist's or the Language User's?" Cognitive Linguistics 6, 89-130.
- Sehnert, J. and M. Sharwood-Smith. (1973) "The Verbalization of Instrumentals in English," Studia Anglica Posnaniensia 5, 37-46.
- Seto, K. (1986) Retorikku no Uchuu (The Universe of Rhetoric). Tokyo: Kaimeisha.
- Seto, K. (1995) Kuukan no Retorikku (Rhetoric of Space). Tokyo: Kaimeisha.
- Smith, C. (1970) "Jespersen's 'Move and Change' Class and Causative Verbs in English," in M. A. Jazayery, E. C. Palome, W. Winter (eds.), Linguistics and Literary Studies in Honor of Archibald A. Hill. Vol. 2: Descriptive Linguistics. 101-109. The Hague: Mouton.
- Sweetser, E. (1990) From Etymology to Pragmatics: The Mind-as-Body Metaphor in Semantic Structure and Semantic Change. Cambridge: Cambridge University Press.
- Takizawa, N. (1987) "Verbal Compounds Reconsidered," Paper read at the Tsukuba English Linguistics Colloquium on April 26, 1987.
- Talmy, L. (1988) "The Relation of Grammar to Cognition," in Rudzka-Ostyn (ed.) Topics in Cognitive Linguistics. 166-205. John Benjamins.
- Tanaka, S. (1987) "The Structure of Prepositional As-Constructions," Studies in English Literature 64:1, 97-114.
- Taylor, J. (1989) Linguistic Categorization: Prototypes in Linguistic Theory. Oxford: Clarendon Press.
- Traugott, E. (1985) "'Conventional' and 'Dead' Metaphors Revisited," in W. Paprotte & R. Dirven (eds.) The Ubiquity of Metaphor: Metaphor in Language and Thought. Amsterdam: John Benjamin.
- Turner, M. (1993) "An Image-Schematic Constraint on Metaphor," in R. Geiger and B. Rudzka-Ostyn (eds.) Conceptualizations and Mental

Processing in Language. 291-306. Berlin; New York: Mouton de Gruyter.

Vandeloise, C. (1990) "Representation, Prototypes, and Centrality," in S. L. Tsohatzidis (ed.) Meanings and Prototypes: Studies in Linguistic Categorization. 403-437. London: Routledge.

Vendler, Z. (1967) Linguistics in Philosophy. Ithaca: Cornell University Press.

Verkuyl, H. and J. Zwarts. (1992) "Time and Space in Conceptual and Logical Semantics: The Notion of Path," Linguistics 30, 483-511.

Wierzbicka, A. (1986) "Precision in Vagueness," Journal of Pragmatics 10, 597-614.

Dictionaries

CAMBRIDGE = Cambridge International Dictionary of English, Cambridge University Press, Cambridge, 1995.

COBUILD = Collins COBUILD English Language Dictionary, Collins, London, 1987.

LDOCE = Longman Dictionary of Contemporary English, 1st edition.

OALD⁴ = Oxford Advanced Learners' Dictionary, 4th edition, Oxford University Press, Oxford, 1989.

ODCIE = Oxford Dictionary of Current Idiomatic English,

筑波大学附属図書館



1 00983 00086 5

本学関係