

# Digital acoustic communication in air using parametric loudspeaker

Riku Fukuda<sup>1a)</sup>, Tadashi Ebihara<sup>1,2a)</sup>, Koichi Mizutani<sup>1,2</sup>,  
and Naoto Wakatsuki<sup>1,2</sup>

<sup>1</sup> Graduate School of Systems and Information Engineering, University of Tsukuba,  
1-1-1 Tennodai, Tsukuba 305-8573, Japan

<sup>2</sup> Faculty of Engineering, Information and Systems, University of Tsukuba,  
1-1-1 Tennodai, Tsukuba 305-8573, Japan

a) [ebihara@iit.tsukuba.ac.jp](mailto:ebihara@iit.tsukuba.ac.jp)

**Abstract:** We propose an acoustic communication system using parametric loudspeaker that emits a communication signal into a limited area. We found that the use of minimum shift keying is suitable, since it has the potential and second harmonic signal that occur when the emit signal is distorted during propagation due to the effect of air. Experiments revealed that the proposed system emits an audible signal to a limited area, achieves a BER of  $10^{-3}$  at  $E_b/N_0$  of 10 dB. Thus, it outperforms benchmarks using other modulation schemes.

**Keywords:** parametric loudspeaker, digital acoustic communication, frequency diversity

**Classification:** Wireless Communication Technologies

## References

- [1] S. Nishihara, N. Shinmen, T. Ebihara, K. Mizutani, and Wakatsuki, "Design of secure near-field communication for smartphones using sound and vibration," Proc. IEEE Global Conference on Consumer Electronics, p. 56, 2017.
- [2] N. Shinmen, T. Ebihara, and K. Mizutani, "Software-based modem for near field acoustic communication," IEEE Global Conference on Consumer Electronics, pp. 152–155, 2012.
- [3] H. Matsuoka, Y. Nakashima, and T. Yoshimura, "Acoustic Communication System Using Mobile Terminal Microphones," *IEICE Trans. Fundamentals*, vol. E91.A, pp. 1652–1658, 2008. DOI:10.1093/ietfec/e91-a.7.1652
- [4] M. Wu, C. Ye, S. Wu, and J. Yang, "Effects on the Performance of Parametric Loudspeaker Caused by Nonideal Ultrasound Transducer," *Appl. Phys.*, vol. 49, 07HE19, 2010.
- [5] C. Ye, Z. Kuang, M. Wu, and J. Yang, "Development of an Acoustic Filter for parametric Loudspeaker in Air," *Appl. Phys.*, vol. 50, 07HE18, 2011.
- [6] C. Shi and W. S. Gan, "Development of Parametric Loudspeaker," *IEEE Potentials*, vol. 29, pp. 20–24, 2010. DOI:10.1109/MPOT.2010.938148
- [7] H. Nomura and R. Nishioka, "Time sidelobe reduction of pulse-compressed parametric ultrasound with maximum-length sequence excitation," *Jpn. J. Appl. Phys.*, vol. 57, 07LC05, 2018. DOI:10.7567/JJAP.57.07LC05
- [8] H. Nomura, T. Nakamura, R. Takagi, and S. Yoshizawa, "Digital acoustic

- communication in air using parametric loudspeaker,” *Jpn. J. Appl. Phys.*, vol. 56, 07LC05, 2018.
- [9] T. D. Kite, J. T. Post, and M. F. Hamilton, “Parametric array in air distortion reduction by preprocessing,” Proc. 16th ICA and 135th Meeting of the ASA, pp. 1091–1092, 1998.
- [10] E. Lindskog and A. Paulraj, “A transmit diversity scheme for channels with intersymbol interference,” IEEE ICC, pp. 207–311, 2000.
- [11] B. Watson, Watkins-Johnson Company, “FSK: Signals and Demodulation,” vol. 7, no. 5, 1980.

## 1 Introduction

Digital acoustic communication in air plays an important role in establishing a wireless link between mobile devices [1, 2]. Existing acoustic communication systems tend to broadcast information using audible sounds, resulting in interference to all unintended receivers [3]. Parametric loudspeakers have the potential to address this problem, since they can create directive low-frequency sounds by exploiting nonlinear ultrasound-medium interaction effects [4, 5]. Many useful applications for such loudspeakers have been proposed, such as sound projectors for public spaces [6], high-resolution imaging [7], and sensing [8]. However, to our knowledge, no acoustic communication system that actively uses the characteristics of the nonlinear acoustic channel has been proposed.

In this paper, we investigate a digital communication scheme that is suitable for acoustic communication using a parametric loudspeaker. Specifically, we design a communication system considering a nonlinear acoustic channel, and perform experiments to evaluate the performance of the proposed system.

## 2 Communication system using parametric loudspeaker

Fig. 1 is a block diagram of the transmitter (Tx) and receiver (Rx) for acoustic communication using a parametric loudspeaker. The signal processing in the Tx is as follows:

1. The Tx reads a message vector of length  $N$ ,  $s = (s_0, s_1, \dots, s_{N-1})$ , where  $s_n = \{0, 1\}$ . Then the Tx performs pulse shaping and obtains pulse signal  $a(t)$ ,

$$a(t) = \begin{cases} 1(s_n = 0) & (nT \leq t \leq (n+1)T), \\ -1(s_n = 1) & (nT \leq t \leq (n+1)T), \end{cases} \quad (1)$$

where  $T$  is the symbol time.

2. The Tx performs digital modulation using minimum shift keying (MSK)—a specific type of frequency shift keying—to obtain a modulated waveform  $b(t)$ ,

$$b(t) = \cos 2\pi \left\{ \left( f_c + \frac{a_n(t)}{4T} \right) t + \varphi_n \right\}, \quad (2)$$

where  $f_0$ ,  $f_1$ , and  $\varphi_n$  are

$$f_0 = f_c + \frac{1}{4T}, \tag{3}$$

$$f_1 = f_c - \frac{1}{4T}, \tag{4}$$

$$\varphi_n = \frac{\pi}{2} \sum_{i=0}^{n-1} (2s_i - 1) \quad (n > 0), \tag{5}$$

respectively, and  $f_c$  is the carrier frequency of MSK.

- The Tx performs amplitude modulation (AM) and emits the modulated signal  $[1 + mb(t)] \sin 2\pi f_2 t$  to the air using the parametric loudspeaker, where  $m$  and  $f_2$  are the modulation index ( $0 < m \leq 1$ ) and carrier frequency of AM, respectively.

The emit signal is distorted during propagation due to the effect of air nonlinearity, and is received by the receiver as

$$r(t) = \frac{P_1^2 A \beta}{16\pi \rho_0 c_0^3 z \alpha} \left\{ 2m \frac{\partial^2}{\partial t^2} b(t) + m^2 \frac{\partial^2}{\partial t^2} b^2(t) \right\}, \tag{6}$$

$$= \frac{P_1^2 \pi A \beta}{4\rho_0 c_0^3 z \alpha} \left\{ -m \left( f_c + \frac{a_n(t)}{4T} \right)^2 \cos \left( 2\pi t \left( \frac{a_n(t)}{4T} + f_c \right) + \varphi_n \right) - 2m^2 \left( f_c + \frac{a_n(t)}{4T} \right)^2 \cos \left( 4\pi t \left( \frac{a_n(t)}{4T} + f_c \right) + 2\varphi_n \right) \right\}, \tag{7}$$

where  $P_1$ ,  $A$ ,  $\beta$ ,  $\rho_0$ ,  $c_0$ ,  $z$  and  $\alpha$  are the pressure amplitude at source, the source radius, the nonlinearity coefficient of the medium, the density of the air, the small signal sound speed, the coordinate along the propagation direction of beams, and the dissipation factor corresponding to thermoviscous absorption, respectively [9]. From Eq. (7), we can find that the received signal  $r(t)$  contains  $b(t)$  and the second harmonic of  $b(t)$ . Since the modulated signal  $b(t)$  appears at two frequency bands, the Rx can improve communication quality by merging two signals with different frequencies (frequency diversity) [10]. Note that the frequency diversity may not be utilizable simply in other digital modulation schemes, such as phase shift keying (PSK), since the phase of the second harmonic of  $b(t)$  is distorted.

The signal processing in the Rx is as follows:

- The Rx performs non-coherent FSK demodulation on the received signal  $r(t)$  [11]. Specifically, the Rx compares two signal powers  $p_0$  and  $p_1$ , where  $p_0$  is the sum of the signal power at the frequencies of  $f_0$  and  $2f_0$ , and  $p_1$  is the sum of the signal power at the frequencies of  $f_1$  and  $2f_1$ .

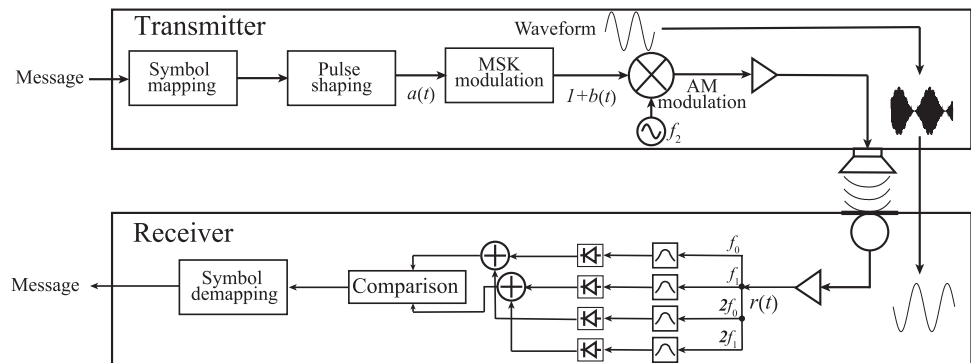
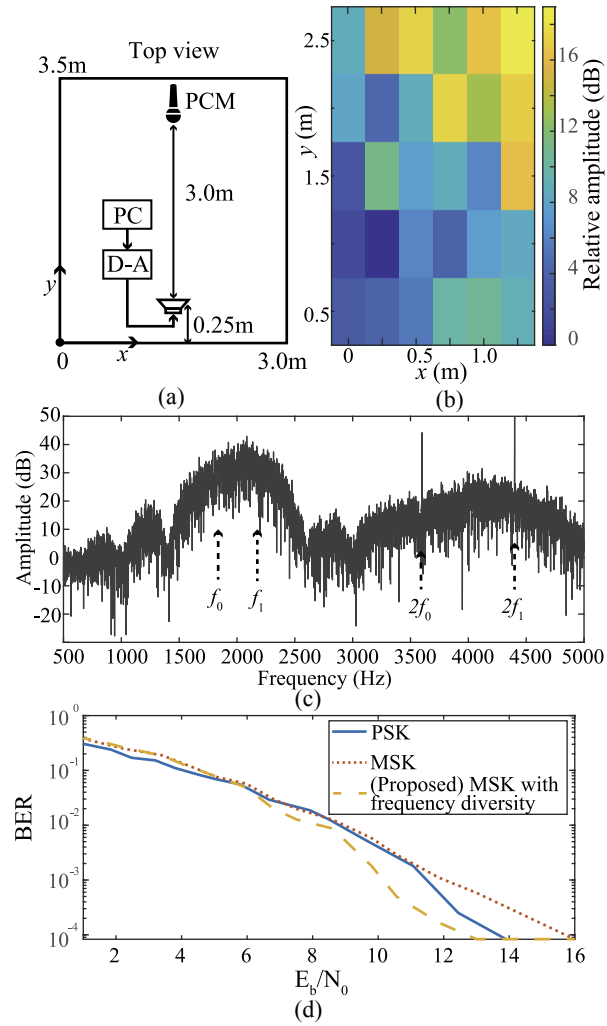

Fig. 1. Block diagram of transmitter and receiver for acoustic



**Fig. 2.** (a): Experimental environment, (b) sound pressure level of the parametric speaker, (c): Power spectrum of received signal  $r(t)$ , and (d): relationship between  $E_b/N_0$  and BER obtained in experiment

2. The Rx outputs a received message vector of length  $N$ ,  $\mathbf{r} = (r_0, r_1, \dots, r_{N-1})$ , where

$$r_n = \begin{cases} 0 & (p_0 \geq p_1), \\ 1 & (p_0 < p_1), \end{cases} \quad (8)$$

### 3 Experiment

We evaluated the performance of the digital acoustic communication system using the parametric speaker in experiments. Fig. 2(a) shows the experimental environment. The experiment was performed in an anechoic room. The transmitter consisted of a PC with software modulator (LabVIEW, National Instruments), a digital-to-analog converter (USB-6212, National Instruments), and a parametric speaker consisting of 49 emitters (T40-16, Nicera). The receiver consisted of a PCM recorder (CD-05, TASCAM) and a PC with a software demodulator. Table I shows the parameters used in the communication. In this experiment, we measured the relationship between the energy per bit to noise power spectral density ratio

( $E_b/N_0$ ) and the bit error rate (BER). To clarify the advantage of the proposed system (MSK with frequency diversity), communication using MSK without frequency diversity and phase shift keying (PSK) was also performed. Note that the bandwidth of PSK is smaller than that of MSK if we compare them under the same communication speed, so we employ  $E_b/N_0$  as the normalized signal-to-noise ratio.

Fig. 2(b)–2(d) show the experimental results. Fig. 2(b) shows the sound pressure distribution of the communication signal. As shown in the figure, the emit sound was focused at high intensity into a relatively small area, which has the potential to address the problem of conventional acoustic communication. Fig. 2(c) shows the spectrum of the received signal. As shown in the figure, there exist the spectrum of  $b(t)$  and its second harmonics. Fig. 2(d) shows the communication quality obtained in the experiment. As shown in the figure, we found that the proposed MSK with frequency diversity outperforms the benchmarks. Specifically, the proposed system achieved a BER of  $10^{-3}$  at  $E_b/N_0$  of 10.15 dB, while normal MSK and PSK achieved BER of  $4.22 \times 10^{-3}$  and  $3.58 \times 10^{-3}$  at the same  $E_b/N_0$ , respectively. The obtained results suggest that the combination MSK and frequency diversity is suitable for digital acoustic communication using a parametric loudspeaker.

**Table I.** Parameters used in experiment

Parameter		Value
Digital modulation (MSK)	$T$ (ms)	1.25
	$f_0$ (Hz)	1,800
	$f_1$ (Hz)	2,200
	Data rate (bps)	800
	Signal bandwidth (Hz)	1,200
Digital modulation (PSK as reference)	$T$ (ms)	1.25
	$f_0$ (Hz)	2,000
	Data rate (bps)	800
	Signal bandwidth (Hz)	800
Amplitude modulation	$m$	1
	$f_2$ (Hz)	40,000

#### 4 Conclusion

We proposed a digital communication scheme that is suitable for acoustic communication using parametric loudspeaker. Specifically, we design a communication system considering nonlinear acoustic channel, and perform experiments to evaluate the performance of the proposed system. From experiments, it was confirmed that the emit sound from parametric loudspeaker was focused at high intensity into a relatively small area, which has the potential to address the problem of conventional acoustic communication. Furthermore, it was also found that the combination MSK and frequency diversity, which utilizes harmonic distortions, outperform normal MSK and PSK, and is suitable for digital acoustic communication using a parametric loudspeaker.