

Molecular identification of seven species of the genus *Stigmaeopsis* (Acari: Tetranychidae) and preliminary attempts to establish their phylogenetic relationship

HIRONORI SAKAMOTO¹, TOMOKO MATSUDA¹, REIKO SUZUKI¹, YUTAKA SAITO², JIAN-ZHEN LIN², YAN-XUAN ZHANG², YUKIE SATO³ & TETSUO GOTOH^{1,*}

*Correspondence Author: tetsuo.gotoh.acari@vc.ibaraki.ac.jp

¹ Laboratory of Applied Entomology and Zoology, Faculty of Agriculture, Ibaraki University, Ami, Ibaraki 300-0393, Japan

² Institute of Plant Protection, Fujian Academy of Agricultural Sciences, Fuzhou 350013, China

³ Sugadaira Montane Research Center, University of Tsukuba, Ueda, Nagano 386-2204, Japan

Abstract

The genus *Stigmaeopsis* (family Tetranychidae) has 11 species including the serious bamboo pest, *S. nanjingensis*. All *Stigmaeopsis* species are difficult to identify by their morphology, and the diagnostic character (the length of dorsal setae) can be used only to identify fresh specimens. To identify these species at the molecular level, we sequenced the cytochrome *c* oxidase subunit I (COI) gene of mitochondrial DNA and two nuclear ribosomal RNA genes (18S and 28S) of 20 strains of seven species of *Stigmaeopsis* [*S. celarius*, *S. longus*, *S. miscanthi* (both low- and high-aggression phenotypes), *S. nanjingensis*, *S. tenuinidus*, *S. saharai* and *S. takahashii*]. In maximum likelihood (ML) phylogenetic trees of both COI and combined 18S-28S genes, all but one *Stigmaeopsis* species could be identified as a monophyletic clade with high bootstrap values. The present results strongly suggested that the exceptional species, *S. miscanthi*, consists of three biologically different entities based on two phylogenetic trees. Though the phylogenetic trees did not comprehensively solve the phylogeny of *Stigmaeopsis*, a phylogenetic tree based on the combined nuclear genes showed a sibling relationship between two sub-social *Stigmaeopsis* species, *S. miscanthi* and *S. longus*. In addition, diagnostic PCR detected *Wolbachia* or *Cardinium*, which frequently affect mitochondrial haplotypes, in *S. longus* and *S. nanjingensis*. In the COI tree, *S. longus* was separated into two groups which were more consistent with their bacterial infection status than with their geographical distribution.

Key words: DNA-based identification, mitochondrial DNA, rDNA, symbiont, *Schizotetranychus*

Introduction

The genus *Stigmaeopsis* consists of 11 species in the family Tetranychidae (Saito *et al.* 2004, 2016; Flechtman 2012). All species appear on Poaceae species such as bamboo, dwarf bamboo, reed grass and silver grass. Identification of species in this genus has been based on both the length of the dorsal setae and distance between the bases of specific dorsal setae (Saito 2009). However, setae are frequently worn down by constant contact with threads in the ceiling of their nests. Thus, to accurately identify mites, they must be reared for more than one generation and many microscope slides must be prepared to make setae measurements in newly emerged females. Such morphological identification requires expertise and experience.

Another identification strategy is molecular analysis based on DNA sequences. The internal transcribed spacer 2 (ITS2) region of nuclear ribosomal RNA (rRNA) genes (Navajas & Boursot 2003; Noge *et al.* 2005; Ben-David *et al.* 2007) and the cytochrome *c* oxidase subunit I (COI) gene of

mitochondrial DNA (mtDNA) (Matsuda *et al.* 2012, 2013) have been used to identify spider mite species. Once molecular identification corresponds with morphological identification, it can be used to determine species rapidly and without a need for expertise in morphology. DNA-based molecular identification can also discover new invasive species (Wang & Qiao 2009) and cryptic species (Carew *et al.* 2011; Matsuda *et al.* 2013).

Except for the recently described *S. temporalis* Saito *et al.* (Saito *et al.* 2016), five species of *Stigmaeopsis* have been identified and phylogenetically investigated in Japan. These five Japanese species were reported to belong to five distinct groups based on the COI gene of mtDNA (Ito & Fukuda 2009; Ito *et al.* 2011). Based on the 28S rRNA gene, these five species were clearly divided into two groups, which well corresponded to the host plants (bamboo species and *Miscanthus* grass species, respectively) (Sakagami *et al.* 2009). Some intraspecific groups were reported from two species, *S. miscanthi* and *S. longus*, based on phylogenetic analyses (Sakagami *et al.* 2009; Ito & Fukuda 2009; Ito *et al.* 2011). *S. miscanthi* has two behavioral phenotypes based on differences in male pugnacity against conspecific males. The two phenotypes have been called the low-aggression (LW) phenotype and the high-aggression (HG) phenotype (Saito & Sahara 1999; Sato *et al.* 2008, 2013), and these phenotypes formed distinct groups in phylogenetic trees of the 28S rRNA gene (Sakagami *et al.* 2009) and COI gene (Ito & Fukuda 2009; Ito *et al.* 2011). *S. longus* also forms two distinct groups in a phylogenetic tree based on the COI gene; one is distributed in the northern part of Japan (from Hokkaido Prefecture to Yamagata Prefecture) and the other is distributed in the southern part of Japan (from Yamagata Prefecture to the Kyushu district), suggesting that there were two routes of expansion of this species (Ito *et al.* 2011). Indeed, during the glacial age, many plants and animals in the Japanese Archipelago likely arrived from the Asian continent via land bridges between Sakhalin and Hokkaido Islands and between the Korean Peninsula and the Kyushu Islands (Masuda & Abe 2005).

To develop a DNA-based species identification method for the genus *Stigmaeopsis*, we determined the COI (618 bp), 18S (1863 bp) and 28S (671 bp) rRNA gene sequences of seven out of the 11 known species in the world (Flechtmann 2012; Saito *et al.* 2016). To better understand the phylogenetic relationship among these species, we also tried to detect the presence or absence of two intracellular endosymbiotic bacteria, *Wolbachia* and *Cardinium*, which frequently affect the genetic structure and diversity of the host species (Turelli *et al.* 1992; Gotoh *et al.* 2007; Yu *et al.* 2011; Zhang *et al.* 2013). Furthermore, these intracellular endosymbiotic bacteria frequently affect mitochondrial haplotypes of spider mite species (Zhang *et al.* 2013).

Materials and Methods

Mites. Seven *Stigmaeopsis* species (15 strains and 5 strains previously reported by us) were used in this study (Table 1). The mite samples were maintained on leaf discs of the original host plants. The leaves were placed on a water-saturated polyurethane mat in a plastic dish (90 mm diameter, 20 mm depth). The mites were reared at 25°C and under a 16:8 h light:dark photoperiod until analysis. After the laboratory strains were established, newly emerged samples with complete dorsal setae were mounted in Hoyer's medium and identified under phase-contrast and differential interference-contrast microscopes. Sn_Nanping and Sn_Huanxi strains of *S. nanjingensis* (Ma & Yuan), Ste_Guiyan and Ste_Hongliao strains of *S. tenuinidus* (Zhang & Zhang), and Sm_(Cn) strain of *S. miscanthi* were established at China using the above-mentioned methods. More than ten individuals of each strain were preserved in 99 % ethanol and sent to Ibaraki University for molecular analysis. In addition, adult males and females of each strain with complete dorsal setae were mounted on slides in Hoyer's medium and sent to Ibaraki University for morphological identification. Some of the latter were used as voucher specimens.

TABLE 1. Collection records of seven species of the genus *Stigmaeopsis* and two outgroup species used in this study.

Species	Abbrev.	Date	Locality	Host plant	Bacterial infection		Voucher no. ^a	Accession no.			Reference	
					<i>Wolbachia</i>	<i>Cardinium</i>		18S	28S	COI		
<i>S. celarius</i> Banks	Sc_Ami	7 Aug. 2011	Ami, Ibaraki, Japan	<i>Pleioblastus argenteostriatus</i>	negative	negative	0506	AB926253	AB926344	AB981223	Matsuda et al. (2014)	
	Sc_Kyoto	18 July 2013	Kyoto, Kyoto, Japan	<i>Sasa</i> sp.	negative	negative	0617	LC158879	LC158864	LC158894	This study	
	Sl_Sapporo	4 June 1989	Sapporo, Hokkaido, Japan	<i>Sasa senanensis</i>	positive	negative	0542	AB926254	AB926345	AB981224	Matsuda et al. (2014)	
<i>S. longus</i> (Saito)	Sl_Date	1 Aug. 2012	Date, Hokkaido, Japan	<i>Sasa senanensis</i>	negative	positive	0618	LC158880	LC158865	LC158895	This study	
	Sl_Ami	7 June 2011	Ami, Ibaraki, Japan	<i>Sasa senanensis</i>	positive	negative	0512	LC158881	LC158866	LC158896	This study	
	Sm_(HG)-1	5 Aug. 2011	Boso, Chiba, Japan	<i>Miscanthus sinensis</i>	negative	negative	0499	LC158882	LC158867	LC158897	This study	
<i>S. miscanthi</i> (Saito)	Sm_(HG)-2	5 Aug. 2011	Kamogawa, Chiba, Japan	<i>Miscanthus sinensis</i>	negative	negative	0500	LC158883	LC158868	LC158898	This study	
	Sm_(HG)-3	16 Feb. 2009	Shimabara, Nagasaki, Japan	<i>Miscanthus sinensis</i>	negative	negative	0404	AB926255	AB926346	AB981225	Matsuda et al. (2014)	
	Sm_(HG)-4	13 July 2015	Shimabara, Nagasaki, Japan	<i>Miscanthus sinensis</i>	negative	negative	0709	LC158884	LC158869	LC158899	This study	
	Sm_(LW)-1	14 July 2015	Unzen 1, Nagasaki, Japan	<i>Miscanthus sinensis</i>	negative	negative	0710	LC158885	LC158870	LC158900	This study	
	Sm_(LW)-2	14 July 2015	Unzen 2, Nagasaki, Japan	<i>Miscanthus sinensis</i>	negative	negative	0711	LC158886	LC158871	LC158901	This study	
	Sm_(Ct)	27 May 2015	Mt. Gu, Fujian, China	<i>Miscanthus sinensis</i>	negative	negative	0712	LC158887	LC158872	LC158902	This study	
	Sn_Nanping	2 Sept. 2013	Nanping, Fujian, China	<i>Phyllostachys edulis</i>	positive	negative	0620	LC158888	LC158873	LC158903	This study	
	<i>S. teminidus</i> (Ma & Yuan)	Sn_Huaxi	6 May 2014	Huaxi, Fujian, China	<i>Phyllostachys edulis</i>	negative	negative	0713	LC158889	LC158874	LC158904	This study
		Ste_Guiyan	4 Sept. 2013	Guiyan, Fujian, China	<i>Phyllostachys edulis</i>	negative	negative	0622	LC158890	LC158875	LC158905	This study
	<i>S. saharai</i> (Zhang & Zhang)	Ste_Hongliao	4 Sept. 2013	Hongliao, Fujian, China	<i>Phyllostachys edulis</i>	negative	negative	0621	LC158891	LC158876	LC158906	This study
Ss_Matsudo		27 Aug. 2011	Matsudo, Chiba, Japan	<i>Pleioblastus argenteostriatus</i>	negative	negative	0504	LC158892	LC158877	LC158907	This study	
Saito & Mori	Ss_Kamogawa	5 Aug. 2011	Kamogawa, Chiba, Japan	<i>Phyllostachys edulis</i>	negative	negative	0501	AB926256	AB926347	AB981226	Matsuda et al. (2014)	
	Sta_Sapporo	27 Oct. 1997	Sapporo, Hokkaido, Japan	<i>Sasa senanensis</i>	negative	negative	0541	AB926257	AB926348	AB981227	Matsuda et al. (2014)	
<i>Tetranychus urticae</i> Koch	Sta_Kimobetsu	23 Oct. 2012	Kimobetsu, Hokkaido, Japan	<i>Sasa senanensis</i>	negative	negative	0619	LC158893	LC158878	LC158908	This study	
	Tu	16 July 2001	Takikawa, Hokkaido, Japan	<i>Citrus latifolia</i>	N. E. ^b	N. E.	0181	AB926312	AB926403	AB736076	Matsuda et al. (2014)	
<i>T. kanzawai</i> Kishida	Tk	19 May 1993	Shimada, Shizuoka, Japan	<i>Camellia sinensis</i>	N. E.	N. E.	0158	AB926298	AB926389	AB736043	Matsuda et al. (2014)	

^a Voucher specimens are preserved at the Laboratory of Applied Entomology and Zoology (Faculty of Agriculture, Ibaraki University) under the serial voucher specimen numbers.^b Not examined.

Phylogenetic analysis. Mites were randomly selected from each strain or from 99 % ethanol-preserved strains. Total DNA was extracted from the whole body of each female with a Wizard Genomic DNA Purification Kit (Promega, Madison, WI). Live female individuals for DNA samples and female individuals for voucher specimen were obtained from the same leaf discs. PCR primers are given in Table 2. PCR amplification was performed with the following profile: 3 min at 94°C, followed by 35 cycles of 1 min at 94°C, 1 min at 45°C (COI), 55°C (28S region) or 65°C (18S region) and 1.5 min at 72°C. An additional 10 min at 72°C was allowed for last strand elongation. The resultant DNA solutions were purified using MinElute PCR Purification Kit (Qiagen, Valencia, CA) and sequenced directly. Sequencing was carried out in both directions using the amplifying primers with a BigDye Terminator Cycle Sequencing Kit v. 3. 1 (Applied Biosystems, Foster City, CA) and on an ABI 3130xl automated sequencer.

TABLE 2. Primers used in polymerase chain reaction amplification and sequencing of the rDNA (18S and 28S regions) and mtDNA (COI gene).

Primer name			Sequence (5' to 3')	Reference
18S region				
18S-1F	F primer	5'-	ACCGCGAATGGCTCATTAAATCAGTT	-3' Matsuda <i>et al.</i> (2014)
18S-2F	F primer	5'-	TGGCCTCTGAGCCGACGATGTAT	-3'
18S-2R	R primer	5'-	ACCCCATAGGTTTCGACTGAAATC	-3'
18S-5R	R primer	5'-	TCCAATAGATCCTCGTTAAAGGAT	-3'
18S-8R	R primer	5'-	TCTCGTTCGTTATCGGAATTAAC	-3'
18S-9F	F primer	5'-	AGCTTCCGGGAAACCAAAGTTT	-3'
18S-9R	R primer	5'-	AGGGCATCACAGACCTGTTATT	-3'
18S-10F	F primer	5'-	AGTTGGTGGAGTGATTTGTCTGGT	-3'
28S region				
28v-5'	F primer	5'-	AAGGTAGCCAAATGCCTCATC	-3' Hillis & Dixon (1991), Palumbi (1996)
28jj-3'	R primer	5'-	AGTAGGGTAAACTAACCT	-3'
5' half of COI (≈700 bp)				
C1-J-1718-Stig1	F primer	5'-	GGAGGATTTGGTAATTGGCTTATCCC	-3' Matsuda <i>et al.</i> (2014), This study
C1-J-1718-Stig2	F primer	5'-	GGAGGTTTTGGTAATTGGTTAATCCC	-3'
COIREVA-Stig1	R primer	5'-	GAAAGAACATAATGAAAATGAGCAAC	-3'
3' half of COI (≈300 bp)				
mtD03nf	F primer	5'-	TTYGAYCCWAGAGGAGGAGG	-3' Matsuda <i>et al.</i> (2012)
mtD01nr	R primer	5'-	AAACCTARAAAATGTTGWGG	-3'

All sequence data obtained were deposited in DDBJ/EMBL/GenBank International Nucleotide Sequence Databases (Table 1). Sequences obtained and cited from our previously published data (Matsuda *et al.* 2014) were aligned using CLUSTAL W (Thompson *et al.* 1994) and numbers or parsimony-informative sites were calculated using MEGA6 software (Tamura *et al.* 2013). Gaps included in the 28S and 18S sequences were treated using the complete deletion option in MEGA6. Sequences for *Tetranychus urticae* Koch (green form) and *T. kanzawai* Kishida (Matsuda *et al.*

2014) were used as a single outgroup. The robustness of the branches was tested by bootstrap analysis (Felsenstein 1985) with 1,000 replications. Maximum likelihood (ML) trees of both mtDNA and nuclear genes were constructed with RAxML (Stamatakis 2006). For all analyses, we used the GTR Gamma model selected by the Akaike Information Criterion (AIC) using the program Kakusan4 (Tanabe 2011). The RAxML search was executed for the best-scoring ML tree in one single program run (the '-f a' option) instead of the default maximum parsimony-starting tree. Statistical support was evaluated with 1,000 rapid bootstrap inferences. Then, genetic distances (Kimura 2 parameter distances) between the COI genes of *Stigmaeopsis* species were calculated using MEGA6.

Diagnostic PCR of *Wolbachia*/Cardinium infection. The DNA samples used for phylogenetic analysis were also used as diagnostic PCR templates. Primer pairs of diagnostic PCR of *Wolbachia* (*wsp* gene; Zhou *et al.* 1998) and *Cardinium* (16S rRNA gene; Morimoto *et al.* 2006) are given in Table 3. PCR amplification was performed with the following profile: 2 min at 95°C, followed by 35 cycles of 0.5 min at 95°C, 0.5 min at 52°C and 0.5 min at 72°C. An additional 5 min at 72°C was allowed for last strand elongation. PCR products were run on 2% agarose gels to observe DNA bands with the expected size (*Wolbachia-wsp* gene, 610 bp; *Cardinium*-16S rRNA gene, 470 bp).

TABLE 3. Primers used in diagnostic PCR of *Wolbachia* and *Cardinium* infection.

Target microorganism	Primer name		Sequence (5' to 3')	Reference
<i>Wolbachia</i>	<i>Wolbachia</i> surface protein (WSP)			
	Wsp-81F	F primer	5'- TGGTCCAATAAGTGATGAAGAACTAGCTA -3'	Zhou <i>et al.</i> (1998)
	Wsp-691R	R primer	5'- AAAAATTAACGCTACTCCAGCTTCTGCAC -3'	
<i>Cardinium</i>	16S rRNA			
	CFB-fl	F primer	5'- GGAACCTTACCTGGGCTAGAATGTATT -3'	Morimoto <i>et al.</i> (2006)
	CFB-r1	R primer	5'- GCCACTGTCTTCAAGCTCTACCAAC -3'	

Results

COI gene of mtDNA. We obtained COI sequences of 15 strains of seven species determined in this study and five strains of five species from our previously published data (Table 1). None of the COI sequences contained insertions or deletions. After alignment, the COI fragment had 618 nucleotide sites, of which 282 were parsimony-informative sites.

In a ML tree based on the COI sequences, six of the seven *Stigmaeopsis* species (all except *S. miscanthi*) formed a monophyletic clade with high bootstrap values (Fig. 1). The interspecific genetic distances of the genus *Stigmaeopsis* (8.4–14.7%) were clearly higher than intraspecific genetic distances (0.0–2.5%) with one exception (Table 4). The exception was *S. miscanthi*, which showed low intra-group genetic distances (0.0–0.8%) but abnormally high inter-group genetic distances. The latter were 9.4–9.6% between Sm_(HG) and Sm_(LW), 8.1–8.5% between Sm_(HG) and Sm_(Cn) and 8.7% between Sm_(Cn) and Sm_(LW). The clade of *S. miscanthi* was divided into three groups as Sm_(HG), Sm_(LW) and Sm_(Cn) with deeply separated branches.

S. longus consisted of two groups within a monophyletic clade, and the split did not appear to be due to geographical distance because the SI_Sapporo strain (Hokkaido Prefecture, Japan) and the SI_Ami strain (Ibaraki Prefecture, Japan) belonged to the same group, whereas the SI_Date strain (Hokkaido Prefecture, Japan) made a different group. The highest intraspecific genetic distance was 2.5% (Table 4).

Nuclear rRNA genes. We obtained 18S and 28S rRNA gene sequences of 15 strains of seven species determined in this study and five strains of five species from our previously published data (Table 1). Both nuclear genes contained a number of insertions and deletions. After alignment, the 18S fragment had 1,863 nucleotide sites, of which 495 were parsimony-informative sites. Similarly, after alignment, the 28S fragment had 671 nucleotide sites, of which 201 were parsimony-informative.

In a ML tree based on the combined 18S and 28S rRNA sequences (Fig. 2), all but one *Stigmaeopsis* species formed a monophyletic clade with high bootstrap values. The exception was *S. miscanthi*, which was divided into three groups as it was in the COI tree. In contrast, all three strains of *S. longus*, which consisted of two groups in the COI tree, formed a single clade with a high bootstrap value. Furthermore, a sibling relationship between two sub-social *Stigmaeopsis* species, *S. miscanthi* and *S. longus*, was supported in the combined ML tree (74% bootstrap values, Fig. 2).

Bacterial infection. Two strains of *S. longus* (Sl_Sapporo and Sl_Ami) and one strain of *S. nanjingensis* (Sn_Nanping) were positive for *Wolbachia* and one strain of *S. longus* (Sl_Date) was positive for *Cardinium* (Table 1). None of the remaining strains were positive for either bacterium.

TABLE 4. Per cent of intra- and inter specific genetic distances (Kimura 2 parameter distances) in COI gene of mtDNA among seven *Stigmaeopsis* species.

	Sc_ Ami	Sc_ Kyo-	Sl_ Sapporo	Sl_ Date	Sl_ Ami	Sm_ (HG)-1	Sm_ (HG)-2	Sm_ (HG)-3	Sm_ (HG)-4	Sm_ (LW)-1	Sm_ (LW)-2	Sm_ (Cn)-1	Sn_ Nan	Sn_ Huanxi	Ste_ Gui	Ste_ Hong	Ss_ Matsudo	Ss_ Kamo-gawa	Sta_ Sapporo	Sta_ Kimobetsu
Sc_ Ami																				
Sc_ Kyo-	0.3																			
Sl_ Sapporo	9.7	9.9																		
Sl_ Date	9.7	9.5	2.5																	
Sl_ Ami	9.7	9.9	0.0	2.5																
Sm_ (HG)-1	9.7	9.5	10.1	9.5	10.1															
Sm_ (HG)-2	9.7	9.5	10.1	9.5	10.1	0.0	0.0													
Sm_ (HG)-3	9.7	9.5	10.1	9.5	10.1	0.0	0.0													
Sm_ (HG)-4	10.1	9.9	10.1	9.5	10.1	0.8	0.8	0.8												
Sm_ (LW)-1	10.1	9.9	9.1	9.1	9.1	9.6	9.6	9.6	9.4											
Sm_ (LW)-2	10.1	9.9	9.1	9.1	9.1	9.6	9.6	9.6	9.4	0.0										
Sm_ (Cn)-1	10.8	11.0	7.9	7.9	7.9	8.4	8.5	8.5	8.1	8.7	8.7									
Sn_ Nanping	13.4	13.6	13.1	12.9	13.1	14.1	14.0	14.1	14.7	14.5	14.5	13.9								
Sn_ Huanxi	13.4	13.6	13.1	12.9	13.1	14.1	14.1	14.1	14.7	14.5	14.5	13.9	0.0							
Ste_ Guiyang	10.0	10.2	11.1	10.6	11.1	10.6	10.6	10.6	10.8	12.5	12.5	10.1	14.9	14.9						
Ste_ Hongliao	10.0	10.2	11.1	10.6	11.1	10.6	10.6	10.6	10.8	12.5	12.5	10.1	14.9	14.9	0.0					
Ss_ Matsudo	8.8	8.6	9.7	8.8	9.7	9.9	9.9	9.9	9.9	9.7	9.7	9.5	13.9	13.9	11.2	11.2				
Ss_ Kamo-gawa	8.6	8.4	9.5	8.6	9.5	9.7	9.7	9.7	9.7	9.5	9.5	9.3	13.7	13.7	11.0	11.0	0.2			
Sta_ Sapporo	11.0	10.8	9.0	9.0	9.0	11.4	11.4	11.4	11.4	13.2	13.2	11.2	14.7	14.7	11.9	12.0	9.1	9.3		
Sta_ Kimobetsu	10.8	10.6	8.8	8.8	8.8	11.2	11.2	11.2	11.2	13.0	13.0	11.1	14.5	14.5	11.7	11.7	8.9	9.1	0.2	

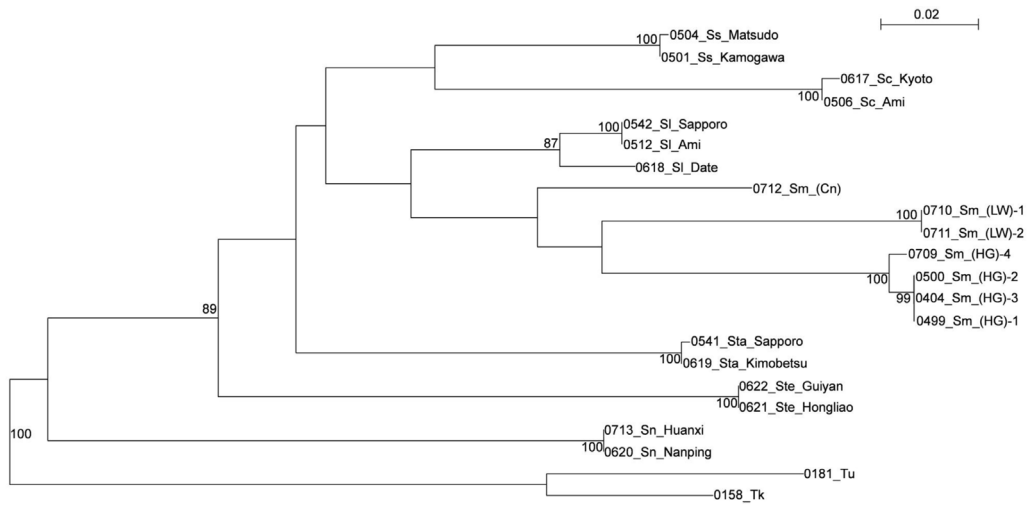

FIGURE 1. Maximum likelihood (ML) phylogenetic tree of the genus *Stigmaeopsis* based on the COI gene of mtDNA (618 bp) using the GTR gamma model. Bootstrap values (>50%) based on 1,000 replications are indicated at the nodes. Each operational taxonomic unit is indicated by the voucher specimen number and abbreviation (see Table 1).

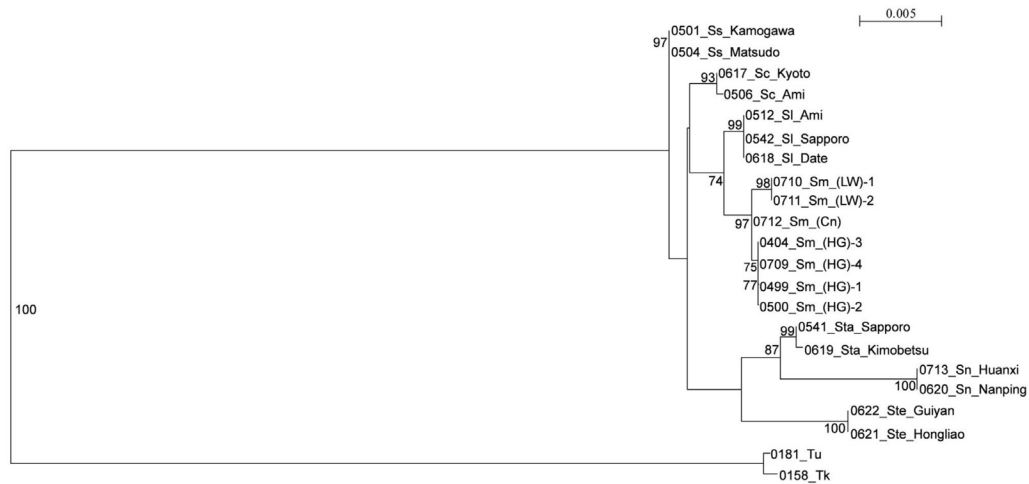

FIGURE 2. Maximum likelihood (ML) phylogenetic tree of the genus *Stigmaeopsis* based on the nuclear 18S and 28S rRNA genes (total 2534 bp) using the GTR gamma model. Bootstrap values (>50%) based on 1,000 replications are indicated at the nodes. Each operational taxonomic unit is indicated by the voucher specimen number and abbreviation (see Table 1).

Discussion

In this study, we examined the efficiency of DNA-based identification of seven morphologically similar species of *Stigmaeopsis* (five Japanese species and two Chinese species). Identifications were based on the sequences of the COI gene of mtDNA and two nuclear rRNA genes (28S and 18S

regions). The 28S and 18S regions were combined to construct the phylogenetic tree by the ML method. In both trees, all but one *Stigmaeopsis* species formed a monophyletic clade with high bootstrap values (Figs. 1 and 2). The exception was *S. miscanthi*, which was divided into three groups in both trees. Our results contribute to the molecular-based rapid identification method of this genus, which includes the severe bamboo pest species, *S. nanjingensis* (Zhang *et al.* 2000). Recently, *S. nanjingensis* invaded Europe (Pellizari & Duso 2009) and severely damaged bamboo species, especially Moso bamboo, *Phyllostachys pubescens* Mazel ex Houz, which is used in construction, furniture and food. Our findings should enable rapid identification of this species in the early stage of their invasions.

Hypotheses about the evolutionary relationship of *Stigmaeopsis* species have been based on molecular analysis, morphology and host plants (Sakagami *et al.* 2009; Ito & Fukuda 2009; Ito *et al.* 2011). In this study, we were unable to determine a comprehensive phylogeny of *Stigmaeopsis*. The deep-level relationships were especially unresolved, as shown by the insufficient bootstrap values of our phylogenetic trees of mtDNA and combined nuclear genes (Figs. 1 and 2). Interestingly, the combined 18S and 28S tree showed a sibling relationship between two sub-social *Stigmaeopsis* species, *S. miscanthi* and *S. longus* (74% bootstrap values, Fig. 2). Sakagami *et al.* (2009) made a similar conclusion based on just the 28S rRNA gene. However, this sibling relationship was not strongly supported by the results of mtDNA (26% bootstrap values, Fig. 1). Finding the appropriate outgroup of *Stigmaeopsis* may help to solve the phylogenetic relationship of *Stigmaeopsis* mites. In recent years, the range of the genus *Stigmaeopsis* was extended. Flechtmann (2012) transferred *S. malkovskii* (Wainstein) and *S. meghalensis* (Gupta & Gupta) from *Schizotetranychus* to *Stigmaeopsis*. Further, Saito *et al.* (2016) described two novel *Stigmaeopsis* species (*S. temporalis* and *S. tegmentalis* Saito et Lin). Further investigations of the phylogenetic relationship of *Stigmaeopsis* species including these latter added species are needed.

Two behavioral phenotypes of *S. miscanthi*, the low-aggression (LW) and high-aggression (HG) phenotypes based on male aggressiveness, were previously reported (Saito & Sahara 1999; Sato *et al.* 2008, 2013). The two phenotypes were basically shown to be two separate clades based on their nuclear 28S gene (Sakagami *et al.* 2009) and COI gene of mtDNA (Ito & Fukuda 2009). In our study, these two phenotypes also formed different clades and the Sm_(Cn) strain of *S. miscanthi* formed a third clade (Figs. 1 and 2), which is predicted to have an intermediate-aggression phenotype (between the LW and HG phenotypes) from the morphology of the male weapon (Sato *et al.* unpublished). Especially in the COI tree, the Sm_(Cn) strain and the other two strains formed deeply separated branches. Furthermore, the abnormally high inter-group genetic distances between Sm_(HG) and Sm_(LW), between Sm_(HG) and Sm_(Cn) and between Sm_(Cn) and Sm_(LW) (Table 4) support the existence of the species-level separation among these three strains. To see whether the Sm_(Cn) strain belongs to *S. miscanthi* will require an accurate re-examination of morphological and behavioral characters as well as crossing experiments.

Both *Wolbachia* and *Cardinium* were detected in different strains of *S. longus*. *Wolbachia* was also found in the Sn_Nanping strain of *S. nanjingensis*. This is the first record of *Wolbachia* infection in *Stigmaeopsis* mites. On the other hand, *Cardinium* infection was previously recorded in *S. celarius* Banks and *S. longus* (Nakamura *et al.* 2009). In general, these intracellular bacteria and the mitochondria are maternally inherited, so that the mitochondrial genome will be in strong linkage with the endosymbionts. Furthermore, in mites, *Wolbachia* is mainly known for inducing reproductive alterations such as cytoplasmic incompatibility (CI) and parthenogenesis induction (Weeks & Breeuwer 2001; Gotoh *et al.* 2003). Likewise, *Cardinium* causes CI (Gotoh *et al.* 2007; Ros & Breeuwer 2009) and feminization of mites that are genetically male (Weeks *et al.* 2001). Interestingly, in the mtDNA tree, the clade of *S. longus* was consistent with the bacterial infection status: the *Wolbachia*-infected SI_Sapporo strain (Hokkaido Prefecture) and the SI_Ami strain

(Ibaraki Prefecture) formed the same group, and the *Cardinium*-infected SI_Date-strain (Hokkaido Prefecture) belonged to a different group. However, all three strains belonged to the same clade in the nuclear gene tree. Likewise, in *Tetranychus truncatus* Ehara, Zhang *et al.* (2013) showed that the distribution of mtDNA haplotypes was associated with *Wolbachia*-infection status rather than with geographical distribution. In the genus *Stigmaeopsis*, the phenotypes induced by these bacteria are unknown, although in *S. longus*, the bacteria might be responsible for a divergence of the COI gene. From the viewpoint of invasive biology, the finding that the invasive pest mite, *S. nanjingensis*, is infected with *Wolbachia* in their naturally distributed area might help to identify their source.

Based on an analysis of the COI gene, Ito *et al.* (2011) divided *S. longus* into two regional subgroups, the northern group distributed from Hokkaido Prefecture, which was their northernmost area in Japan, to Yamagata Prefecture and the southern group distributed from Yamagata Prefecture to the Kyushu district. If this division is correct, the SI_Sapporo strain collected in Hokkaido Prefecture should belong to the northern group. However, analysis of our COI dataset combined with the COI dataset of Ito *et al.* (2011) showed that the SI_Sapporo strain belonged to the southern group (data not shown). This division is consistent with the observation that the genetic distance between the SI_Sapporo strain and the SI_Date strain (2.5%) was the same as that between the SI_Ami strain and the SI_Date strain (2.5%; Table 4). These data strongly suggest that *S. longus* was divided by *Wolbachia/Cardinium* infection rather than by a north-south regional difference. We cannot exclude the possibility that *S. longus* has a widely distributed cryptic species that cannot be identified by 18S and 28S gene sequences or differentiated by morphological characters. Further phylogenetic studies of a large number of infected and uninfected samples from different regions are needed to settle this question.

Acknowledgements

We are deeply grateful to Drs. Y. Kitashima and Jie Ji for collecting spider mites. This work was supported in part by JSPS KAKENHI Grant Number JP25292033, and supported from China Recruitment Program of Global Experts (Foreign Experts) (no. 2012-323) and the Sate Administration of Foreign Experts Affairs Key Project for Introduction of Foreign Expert (no. SZ2013003).

References

- Ben-David, T., Melamed, S., Gerson, U. & Morin, S. (2007) ITS2 sequences as barcodes for identifying and analyzing spider mites (Acari: Tetranychidae). *Experimental and Applied Acarology*, 41, 169–181.
<https://doi.org/10.1007/s10493-007-9058-1>
- Carew, M.E., Marshall, S.E. & Hoffmann, A.A. (2011) A combination of molecular and morphological approaches resolves species in the taxonomically difficult genus *Procladius* Skuse (Diptera: Chironomidae) despite high intra-specific morphological variation. *Bulletin of Entomological Research*, 101, 505–519.
<https://doi.org/10.1017/S000748531100006X>
- Flechtmann, C.H.W. (2012) *Schizotetranychus*-like spider mites (Acari, Prostigmata, Tetranychidae)—revisited, new combinations and a key to groups of *Schizotetranychus* based on females. *Acarologia*, 52, 87–95.
<https://doi.org/10.1051/acarologia/20122039>
- Felsenstein, J. (1985) Confidence limits on phylogenies: an approach using the bootstrap. *Evolution*, 39, 783–791.
<https://doi.org/10.2307/2408678>
- Gotoh, T., Noda, H. & Hong, X.-Y. (2003) *Wolbachia* distribution and cytoplasmic incompatibility based on a survey of 42 spider mite species (Acari: Tetranychidae) in Japan. *Heredity*, 91, 208–216.

- <https://doi.org/10.1038/sj.hdy.6800329>
- Gotoh, T., Noda, H. & Ito, S. (2007) *Cardinium* symbionts cause cytoplasmic incompatibility in spider mites. *Heredity*, 98, 13–20.
- <https://doi.org/10.1038/sj.hdy.6800881>
- Hillis, D.M. & Dixon, M.T. (1991) Ribosomal DNA: molecular evolution and phylogenetic inference. *Quarterly Review of Biology*, 66, 411–453.
- <https://doi.org/10.1086/417338>
- Ito, K. & Fukuda, T. (2009) Molecular phylogeny of *Stigmaeopsis* spider mites (Acari: Tetranychidae) based on the Cytochrome Oxidase subunit I (COI) region of mitochondrial DNA. *Applied Entomology and Zoology*, 44, 343–355.
- <https://doi.org/10.1303/aez.2009.343>
- Ito, K., Yokokawa, N., Hayakawa, H., Minamiya, Y., Yokoyama, J. & Fukuda, T. (2011) Molecular phylogenetic relationship of *Stigmaeopsis* spider mites (Acari: Tetranychidae) collected from Yamagata Prefecture. *Bulletin of Yamagata University. Natural Science*, 17, 19–29.
- Masuda, R. & Abe, H. (2005) *The Natural History of Zoogeography: Evolutionary biology of distribution and diversity*. Sapporo, Hokkaido University Press, 288 pp. [in Japanese].
- Matsuda, T., Hinomoto, N., Singh, R.N. & Gotoh, T. (2012) Molecular-based identification and phylogeny of *Oligonychus* species (Acari: Tetranychidae). *Journal of Economic Entomology*, 105, 1043–1050.
- <https://doi.org/10.1603/EC11404>
- Matsuda, T., Fukumoto, C., Hinomoto, N. & Gotoh, T. (2013) DNA-based identification of spider mites: molecular evidence for cryptic species of the genus *Tetranychus* (Acari: Tetranychidae). *Journal of Economic Entomology*, 106, 463–472.
- <https://doi.org/10.1603/EC12328>
- Matsuda, T., Morishita, M., Hinomoto, N. & Gotoh, T. (2014) Phylogenetic analysis of the spider mite sub-family Tetranychinae (Acari: Tetranychidae) based on the mitochondrial COI gene and the 18S and the 5' end of the 28S rRNA genes indicates that several genera are polyphyletic. *PLOS ONE*, 9(10), e108672.
- <https://doi.org/10.1371/journal.pone.0108672>
- Morimoto, S., Kurtti, T.J. & Noda, H. (2006) In vitro cultivation and antibiotic susceptibility of a *Cytophaga*-like intracellular symbiote isolated from the tick *Ixodes scapularis*. *Current Microbiology*, 52, 324–329.
- <https://doi.org/10.1007/s00284-005-0349-7>
- Nakamura, Y., Kawai, S., Yukuhiro, F., Ito, S., Gotoh, T., Kisimoto, R., Yanase, T., Matsumoto, Y., Kageyama, D. & Noda, H. (2009) Prevalence of *Cardinium* bacteria in planthoppers and spider mites and taxonomic revision of “*Candidatus Cardinium hertigii*” based on detection of a new *Cardinium* group from biting midges. *Applied and Environmental Microbiology*, 75, 6757–6763.
- <https://doi.org/10.1128/AEM.01583-09>
- Navajas, M. & Boursot, P. (2003) Nuclear ribosomal DNA monophyly versus mitochondrial DNA polyphyly in two closely related mite species: the influence of life history and molecular drive. *Proceedings of the Royal Society of London B: Biological Sciences*, 270 (Suppl. 1), S124–S127.
- <https://doi.org/10.1098/rsbl.2003.0034>
- Noge, K., Mori, N., Tanaka, C., Nishida, R., Tsuda, M. & Kuwahara, Y. (2005) Identification of astigmatid mites using the second internal transcribed spacer (ITS2) region and its application for phylogenetic study. *Experimental and Applied Acarology*, 35, 29–46.
- <https://doi.org/10.1007/s10493-004-1953-0>
- Palumbi, S.R. (1996) Nucleic acids II: the polymerase chain reaction. In: Hills, D.M., Moritz, C. & Mable, B.K. (eds.) *Molecular Systematics*. 2nd, Sunderland, Sinauer Associates, Inc, pp. 205–247.
- Pellizzari, G. & Duso, C. (2009) Occurrence of *Stigmaeopsis nanjingensis* in Europe. *Bulletin of Insectology*, 62, 149–151.
- Ros, V.I.D. & Breeuwer, J.A.J. (2009) The effects of, and interactions between, *Cardinium* and *Wolbachia* in the doubly infected spider mite *Bryobia sarothamni*. *Heredity*, 102, 413–422.
- <https://doi.org/10.1038/hdy.2009.4>
- Saito, Y. (2009) *Stigmaeopsis*. In: Ehara, S. & Gotoh, T. (eds.) *Colored Guide to the Plant Mites of Japan*. Tokyo, Zenkoku Nosan Kyoiku Kyokai, pp. 221–222. [in Japanese]
- Saito, Y. & Sahara, K. (1999) Two clinal trends in male-male aggressiveness in a subsocial spider mite (*Schizotetranychus miscanthi*). *Behavioral Ecology and Sociobiology*, 46, 25–29.
- <https://doi.org/10.1007/s002650050588>
- Saito, Y., Mori, K., Sakagami, T. & Lin, J. (2004) Reinstatement of the genus *Stigmaeopsis* Banks, with descriptions of two new species (Acari, Tetranychidae). *Annals of the Entomological Society of America*, 97, 635–

646.
[https://doi.org/10.1603/0013-8746\(2004\)097\[0635:ROTGSB\]2.0.CO;2](https://doi.org/10.1603/0013-8746(2004)097[0635:ROTGSB]2.0.CO;2)
- Saito, Y., Lin, J.-Z., Zhang, Y.-X., Ito, K., Liu, Q.-Y. & Chittenden, A.R. (2016) Two new species and four new life types in Tetranychidae. *Annals of the Entomological Society of America*, 109, 463–472.
<https://doi.org/10.1093/aesa/sav158>
- Sakagami, T., Saito, Y., Kongchuensin, M. & Sahara, K. (2009) Molecular phylogeny of *Stigmaeopsis*, with special reference to speciation through host plant shift. *Annals of the Entomological Society of America*, 102, 360–366.
<https://doi.org/10.1603/008.102.0303>
- Sato, Y., Saito, Y. & Chittenden, A.R. (2008) The parapatric distribution and contact zone of two forms showing different male-to-male aggressiveness in a social spider mite, *Stigmaeopsis miscanthi* (Acari: Tetranychidae). *Experimental & Applied Acarology*, 44, 265–276.
<https://doi.org/10.1007/s10493-008-9147-9>
- Sato, Y., Egas, M., Sabelis, M.W. & Mochizuki, A. (2013) Male–male aggression peaks at intermediate relatedness in a social spider mite. *Ecology & Evolution*, 3, 2661–2669.
<https://doi.org/10.1002/ece3.661>
- Stamatakis, A. (2006) RAxML-VI-HPC: maximum likelihood-based phylogenetic analyses with thousands of taxa and mixed models. *Bioinformatics*, 22, 2688–2690.
<https://doi.org/10.1093/bioinformatics/btl446>
- Tamura, K., Stecher, G., Peterson, D., Filipiński, A. & Kumar, S. (2013) MEGA6: Molecular evolutionary genetics analysis version 6.0. *Molecular Biology and Evolution*, 30, 2725–2729.
<https://doi.org/10.1093/molbev/mst197>
- Tanabe, A.S. (2011) Kakusan4 and Aminosan: two programs for comparing nonpartitioned, proportional and separate models for combined molecular phylogenetic analyses of multilocus sequence data. *Molecular Ecology Resources*, 11, 914–921.
<https://doi.org/10.1111/j.1755-0998.2011.03021.x>
- Thompson, J.D., Higgins, D.G. & Gibson, T.J. (1994) CLUSTAL W: improving the sensitivity of progressive multiple sequence alignment through sequence weighting, position-specific gap penalties and weight matrix choice. *Nucleic Acids Research*, 22, 4673–4680.
<https://doi.org/10.1093/nar/22.22.4673>
- Turelli, M., Hoffmann, A.A. & McKechnie, S.W. (1992) Dynamics of cytoplasmic incompatibility and mtDNA variation in natural *Drosophila simulans* populations. *Genetics*, 132, 713–723.
- Wang, J.F. & Qiao, G.X. (2009) DNA barcoding of genus *Toxoptera* Koch (Hemiptera: Aphididae): identification and molecular phylogeny inferred from mitochondrial COI sequences. *Insect Science*, 16, 475–484.
<https://doi.org/10.1111/j.1744-7917.2009.01270.x>
- Weeks, A.R. & Breeuwer, J.A.J. (2001) *Wolbachia*-induced parthenogenesis in a genus of phytophagous mites. *Proceedings of the Royal Society of London B: Biological Sciences*, 268, 2245–2251.
<https://doi.org/10.1098/rspb.2001.1797>
- Weeks, A.R., Marec, F. & Breeuwer, J.A.J. (2001) A mite species that consists entirely of haploid females. *Science*, 292, 2479–2482.
<https://doi.org/10.1126/science.1060411>
- Yu, M.-Z., Zhang, K.-J., Xue, X.-F. & Hong, X.-Y. (2011) Effects of *Wolbachia* on mtDNA variation and evolution in natural populations of *Tetranychus urticae* Koch. *Insect Molecular Biology*, 20, 311–321.
<https://doi.org/10.1111/j.1365-2583.2010.01066.x>
- Zhang, Y., Zhang, Z.-Q., Liu, Q., Lin, J. & Ji, J. (2000) An overview of occurrence, development and damage of bamboo mites and their integrated management in Fujian, China. *Systematic and Applied Acarology Special Publications*, 4, 9–17.
<https://doi.org/10.11158/saasp.4.1.4>
- Zhang, Y.-K., Ding, X.-L., Zhang, K.-J. & Hong, X.-Y. (2013) *Wolbachia* play an important role in affecting mtDNA variation of *Tetranychus truncatus* (Trombidiformes: Tetranychidae). *Environmental Entomology*, 42, 1240–1245.
<https://doi.org/10.1603/EN13085>
- Zhou, W., Rousset, F. & O'Neill, S. (1998) Phylogeny and PCR-based classification of *Wolbachia* strains using *wsp* gene sequences. *Proceedings of the Royal Society of London B: Biological Sciences*, 265, 509–515.
<https://doi.org/10.1098/rspb.1998.0324>

Submitted: 23 Sept. 2016; accepted by Zhi-Qiang Zhang: 5 Dec. 2016; published: 5 Jan. 2017