

Factor H gene variants in Japanese: Its relation to atypical hemolytic uremic syndrome

Saki Mukai,¹ Yoshihiko Hidaka,² Masako Hirota-Kawadobora,¹ Kazuyuki Matsuda,¹ Noriko Fujihara,¹ Yuka Takezawa,¹ Seiko Kubota,¹ Kenichi Koike,² Takayuki Honda,^{1,3} Kazuyoshi Yamauchi^{4*}

¹ Department of Laboratory Medicine, Shinshu University Hospital, Japan

² Department of Pediatrics, Shinshu University School of Medicine, Japan

³ Department of Laboratory Medicine, Shinshu University School of Medicine, Japan

⁴ Department of Medicine, Molecular Clinical Pathology, Graduate School of Comprehensive Human Sciences, University of Tsukuba

***Address correspondence to:** Kazuyoshi Yamauchi, PhD, Department of Medicine, Molecular Clinical Pathology, Graduate School of Comprehensive Human Sciences, University of Tsukuba, 1-1-1 Tennoudai, Tsukuba, 305-8575, Japan, Tel & FAX: +81-29-853-3456, e-mail: yamauchi@md.tsukuba.ac.jp

Running Title: Factor H in Japanese aHUS patients

Declarations

Competing interests: None

Ethical approval: The study was approved by the ethics committee of Shinsyu University (approval No., 221).

Guarantor: KY

Contributorship: KY has designed and supervised the project, SM, YH, MH, and KM have carried out the project, SM has written the first draft of the manuscript, NF, YK and SK have been the laboratory methods consultants, and KK and TH commented on drafts of the manuscript.

Acknowledgements: We gratefully acknowledge Dr Toshiko Kumagai and Dr Mitsutoshi Sugano (Department of Laboratory Medicine, Shinshu University Hospital) for their advices and encouragement. This work was partially supported by Nagano Society for the Promotion of Science.

Abstract

Mutations and polymorphisms of factor H gene (*FHI*) are known to be closely involved in the development of atypical hemolytic uremic syndrome (aHUS). Several groups have identified disease risk mutations and polymorphisms of *FHI* for the development of aHUS, and have investigated frequencies of aHUS in a number of ethnic groups. However, such studies on Japanese populations are limited. In the present study, we analyzed *FHI* in Japanese aHUS patients and healthy volunteers, and examined whether those variants impacted on a tendency for the development of aHUS in Japanese populations. Similar to previous studies, we found that a high frequency of *FHI* mutations, located in exon 23 of *FHI*, encodes short consensus repeat 20 in C-terminal end of factor H molecule in patients with aHUS (40 %), but not in healthy volunteers. Interestingly, no significant differences in frequency of well-known disease risk polymorphisms for aHUS were observed between healthy volunteers and aHUS patients. Our results suggested that although *FHI* mutations relates to the development of Japanese aHUS in accordance with other ethnic studies, other factor may be required for factor H polymorphism to be a risk factor of Japanese aHUS.

Key words: atypical hemolytic syndrome; factor H; genetic analysis; alternative complement pathway; hemolytic assay

1. Introduction

Hemolytic uremic syndrome (HUS) is a microvasculature disorder characterized by the triad of microangiopathic hemolytic anemia, renal failure, and thrombocytopenia, and is mainly caused by the enterocolitis with Shiga toxin-producing *Escherichia coli* of the serotype O157:H7 (Karmali *et al*, 1983; Karmali *et al*, 1985). This form, known as typical HUS, has a good prognosis, and not often affects family members (Kaplan *et al*, 1998; Ault, 2000; Sánchez-Corral & Melgosa, 2010). In contrast, atypical HUS (aHUS), characterized by the absence of any infection (e.g., Shiga toxin-producing *E. coli*, *Shigella dysenteriae*, and *Streptococcus pneumoniae*) and its associated-diarrhea, tends to relapse and have a poor prognosis (Kaplan *et al*, 1998; Ault, 2000; Sánchez-Corral & Melgosa, 2010), and has been classified as either sporadic or familial (Kaplan *et al*, 1975). Approximately 50% of patients with aHUS have mutations in the genes encoding complement regulatory proteins [e.g., factor H, membrane cofactor protein (MCP or CD46), factor I, factor B, thrombomodulin, and C3] (Atkinson *et al*, 2005; Caprioli *et al*, 2006; Delvaeye *et al*, 2009). In particular, the gene coding factor H, *FHI*, is known to be the most frequently affected in the development of aHUS (Caprioli *et al*, 2006).

Factor H, a 150-kDa plasma glycoprotein predominantly produced in the liver, consists of 20 homologous units of about 60 amino acid residues each, known as short consensus repeats (SCRs) or the complement control protein units (Ault, 2000). Factor H plays a critical role in the regulation of the alternative complement activation pathway; i.e., this complement component is a cofactor for serine protease factor I in cleaving C3b to its inactive form (C3bi) and accelerates decay of the alternative complement pathway C3bBb convertase complex (Weiler *et al*, 1976; Whaley and Ruddy, 1976; Pangburn *et al*, 1977). Several reports demonstrated that anomalous function of factor H, attributed to the mutations

in *FHI*, affects the complementary activation and the pathogenesis of aHUS (Pangburn, 2002; Sánchez-Corral *et al*, 2004; Ferreira *et al*, 2007). Actually, Saunders *et al* (2006) previously demonstrated that the majority of *FHI* mutations in patients with aHUS causes either single amino acid exchange or premature translation interruption within SCR 20, a domain which contains recognition sites for cell surface ligands, and consequently the binding avidity of factor H (to C3b, heparin, or endothelial cells) is reduced.

To date, several linkage analyses have revealed that *FHI* is a candidate gene for aHUS, because its mutations or polymorphisms could be frequently detectable in aHUS patients (Caprioli *et al*, 2001; Richards *et al*, 2001; Caprioli *et al*, 2003; Neumann, *et al*, 2003; Esparza-Gordillo *et al*, 2005). However, to our knowledge, the frequency of *FHI* mutations and polymorphisms and their relation to aHUS in Japanese subjects have not been well-defined.

We designed this study with an aim to characterize factor H and its impact on the clinical phenotype in Japanese aHUS patients. Further, we analyzed the frequency of *FHI* mutations and polymorphisms in Japanese patients with aHUS, their family members, and healthy volunteers to clarify its relevance to the pathogenesis of aHUS.

2. Materials and Methods

2.1. Subjects

DNA samples were extracted from whole peripheral blood leukocytes obtained from aHUS patients [n=10, 3 men and 7 women; age range 1-40 years (mean \pm SE, 19 \pm 5 years)], the family members (for the pedigree analysis), and healthy volunteers [n=15, 3 men and 12 women; age range 26-58 years (mean \pm SE, 41 \pm 3 years)] using QIAamp DNA Blood Mini Kit (Qiagen, Valencia, CA) according to the manufacturer's instructions. We also used 32 healthy volunteer's sera for hemolytic assay. As described previously (Scheiring *et al*, 2010), aHUS was clinically defined as non-diarrheal and non-Shiga toxin HUS. This study was approved by the ethics committee of Shinshu University, Japan (approval No., 221). All subjects gave their informed consent before participation.

2.2. Serum C3

The C3 concentrations in the serum were measured by turbidimetric immunoassay method (Nittobo, Tokyo, Japan) using a BioMajesty JCA-BM 1650 (JEOL, Tokyo, Japan).

2.3. Quantification of Factor H concentration

The factor H concentrations in the serum were measured by the ELISA method as described previously (Oppermann *et al*, 1990). Briefly, commercial polystyrene immunoplates (Nunc, Roskilde, Denmark) were coated with anti-human factor H (ANTIBODYSHOP, Gentofte, Denmark) in 50 mmol/L sodium bicarbonate, pH 10.6 (1.0 mg protein/L) for 24 h at 4 °C. Plates were washed three times with PBS containing 0.5 g/L Tween 20 (PBS-Tween) after each of the subsequent incubation steps. Unoccupied sites were blocked with the blocking buffer (NOF Corp., Tokyo, Japan) for 30 min at room temperature. The prepared

calibrators and samples were then added at 100 $\mu\text{L}/\text{well}$ and incubated for 2 h at room temperature. Biotinylated anti-factor H (ANTIBODYSHOP, Gentofte, Denmark) was added at 100 $\mu\text{L}/\text{well}$ and incubated for 1 h at room temperature. Horseradish peroxidase-conjugated streptavidin (Dako, Glostrup, Denmark), diluted 1,000-fold with PBS-Tween, was then added at 100 $\mu\text{L}/\text{well}$ and incubated for 1 h at room temperature. After final washings, the color reaction was developed with 100 $\mu\text{L}/\text{well}$ of 5 g/L t-methylbenzidine dihydrochloride and hydrogen peroxide. After 30-min incubation at room temperature, the reaction was stopped by adding 50 μL of 0.4 mol/L sulfuric acid, and the absorbance at 450 nm was measured using Personal LAB (Biochem ImmunoSystems, PA). A calibration curve was generated, and the factor H concentration in serum was calculated from the curve. Each assay was carried out at least in duplicate.

2.4. Hemolytic assay

A hemolytic assay was carried out as described previously (Pangburn, 2002) with a small modification. Briefly, sheep erythrocytes were suspended in HEPES buffer (20 mM HEPES, 7 mM MgCl_2 , 10 mM EGTA, 144 mM NaCl, 1% BSA; pH 7.4) to give a final concentration of 5×10^4 cells/ μL . One hundred microliters of the above suspension was mixed with equal volume of serial dilution series of each serum (5, 10, 20, 30, 40, and 50% serum concentration) or saline as a blank, and the mixture was immediately incubated at 37°C for 30 min. After the mixture was centrifuged at 3,500 rpm for 3 min at room temperature, absorbance at 414 nm (A_{414}) of the isolated supernatant was determined using SpectraMax PLUS384 (Molecular Devices Inc., Sunnyvale, CA). The percent hemolytic activity of each sample was determined by subtracting the A_{414} of blank, and dividing by the A_{414} of the control of total lysis (100 μL of serum, 1 μL of 5×10^6 cells/ μL sheep erythrocytes suspension and 99 μL of ammonium chloride solution).

2.5. Screening for factor H antibody

The factor H antibodies in the serum were identified by the ELISA method as described previously (Dragon-Durey *et al*, 2005) with a small modification. Briefly, commercial polystyrene immunoplates were coated with human factor H (Calbiochem, Meudon, France) in PBS (0.3 µg /well) for 24 h at 4 °C. Plates were washed three times after each of the subsequent incubation steps, and blocked unoccupied sites with PBS containing 10 g/L BSA for 1 h at room temperature. The samples were added at 100 µL/well diluted 1:10 for 1 h at room temperature. Horseradish peroxidase-conjugated goat anti-human IgG solution (Denka-Seiken, Tokyo, Japan) was then added at 100 µL/well and incubated for 1 h at room temperature. After final washings, the color reaction was developed using t-methylbenzidine dihydrochloride and hydrogen peroxide. After 30-min incubation at room temperature, the reaction was stopped by adding 100 µL of 0.3 mol/L sulfuric acid, and the absorbance at 450 nm was measured using Personal LAB. Absorbance above the mean + 2SD of those determined by making measurements of 37 healthy volunteers' sera was considered as positive.

2.6. Screening of FHI mutations and polymorphisms

FHI exons were identically amplified by conventional PCR method. The primers used in present study are listed in Table 1. We designed 3 specific primer sets which amplify exons 22 and 23, including C3645T mutation (Ser1191Leu in SCR20) and G3717A mutation (Arg1215Gln in SCR20), and 6 specific primer sets used for recognizing polymorphisms [(C-257T in promoter region, C994A in exon 7 (Ala307Ala in SCR5), G1492A in exon 9 (Ala473Ala in SCR8), A2089G in exon 14 (Gln672Gln in SCR11), G2881T in exon 19 (Glu936Asp in SCR16), and G3364A in exon 20 (Thr1097Thr in SCR18)] according to previous study (Caprioli *et al*, 2003). PCR was performed on a Gene Amp PCR system

9700 (Applied Biosystems, Foster City, CA). After the purification of PCR products, direct DNA sequencing was performed using a BigDye™ Terminator Cycle Sequencing Ready Reaction Kit and an ABI Prism 3100 Genetic Analyzer (both from Applied Biosystems).

2.7. Statistical methods

All experiments were performed at least three times. Data are presented as mean \pm 2SD. Statistical analysis was performed by non-paired *t* test and chi-square test depending on the data set concerned. A *p* value of less than 0.05 was accepted as statistically significant.

3. Results

3.1. Clinical features of patients with aHUS

Clinical features and genetic findings of *FHI* of 10 patients with aHUS were summarized in Table 2 and Table 3, respectively.

Patient 1 (A-6). We analyzed for factor H status using patient's serum, obtained after 1-yr from the episode. Serum factor H level was also significantly decreased (75% of healthy volunteer's serum, $p<0.01$). The heterozygous G3717A mutation, and heterozygous polymorphisms of C-257T, A2089G, G2881T, and G1492A were found in *FHI*. **Anti-factor H antibody was not detected.** Other complement regulatory factors were normal (i.e., factor I level was 14.5 mg/dl, and expression of MCP on lymphocytes was not decreased). The ADAMTS13 activity was normal.

Patient 2 (B-11). We analyzed for factor H status using patient's serum, obtained after 3-yrs from the first episode. Factor H level was slightly increased (114% of healthy volunteer's serum, $p<0.01$). The heterozygous G3717A mutation, and five heterozygous disease risk polymorphisms (C-257T, A2089G, G2881T, C994A, G1492A, and G3364A) were found in *FHI*. **Anti-factor H antibody was not detected.**

Patient 3 (B-12). We analyzed for factor H status using patient's serum, obtained after 7-yrs from the first episode. Factor H level was significantly increased (131% of healthy volunteer's serum, $p<0.01$). The heterozygous G3717A mutation and two heterozygous disease risk polymorphisms (C994A and G1492A) were found in *FHI*. In addition, we found the novel silent mutation [C3013T (His980His)] in exon 18. **Anti-factor H antibody was not detected.**

Patient 4 (C-6). We analyzed for factor H status using patient's serum, obtained after 2-months from the first episode. Factor H level was significantly decreased (74% of

healthy volunteer's serum, $p<0.01$); however, we found neither mutation nor disease risk polymorphism of aHUS in *FHI*. **Anti-factor H antibody was not detected.**

Patient 5 (D-3). We analyzed for factor H status using patient's serum, obtained after 4-yrs from the episode. Factor H level was significantly decreased (64% of healthy volunteer's serum, $p<0.01$); however, we confirmed that this patient had neither mutation nor disease risk polymorphism of aHUS in *FHI*. **Anti-factor H antibody was not detected.**

Patient 6. We analyzed for factor H status using patient's serum, obtained after 6-months from the episode. Serum factor H level was significantly decreased (62% of healthy volunteer's serum, $p<0.01$). **We found neither mutation nor disease risk polymorphism of aHUS in *FHI*, however, we could detect anti-factor H antibody.**

Patient 7. We analyzed for factor H status using patient's serum, obtained on admission. Although serum factor H level was normal, we found heterozygous polymorphisms of A C-257T, C994A, and G3364A in *FHI*. Conservative therapy slowly improved his clinical condition and increased serum factor H level (138% of healthy volunteer's serum, $p<0.01$). **Anti-factor H antibody was not detected.**

Patient 8. We analyzed for factor H status using patient's serum, obtained on admission. Serum factor H level was significantly increased (145% of healthy volunteer's serum, $p<0.01$). The homozygous polymorphisms of C-257T, A2089G, G2881T, and the heterozygous G1492A polymorphism were found in *FHI*. Furthermore, we found C3645T (Ser1191Leu) mutation in exon 23 (data not shown). **Anti-factor H antibody was not detected.**

Patient 9. We analyzed for factor H status using patient's serum, obtained on admission. Serum factor H level was significantly increased (125% of healthy volunteer's serum, $p<0.01$). The homozygous polymorphisms of C-257T, A2089G, G2881T were found in *FHI*. **Anti-factor H antibody was not detected.**

Patient 10. We analyzed for factor H status using patient's serum, obtained on admission. Serum factor H level was also significantly decreased (80% of healthy volunteer's serum, $p < 0.01$). We found the homozygous polymorphisms of C-257T, A2089G, G2881T were found in *FHI*, and detected anti-factor H antibody.

3.2. Pedigree analysis

Further, to clarify the impact of factor H genetic status on the development of aHUS, we analyzed *FHI* mutations and polymorphisms in family members of above 5 patients, and investigated their clinical histories.

Family A. The pedigree of family A is shown in Fig. 1A. We identified that a G3717A mutation of the proband [A-6 (Patient 1)] was inherited from a paternal allele (A-4), and that all three polymorphisms (C-257T, A2089G, G1492A) was from a maternal allele (A-5). The allele sequences of the paternal grandfather (A-1), who died of thrombocytopenic purpura (TTP), were able to be determined from those of the paternal grandmother (A-2) and a paternal uncle (A-3). Taken together, a G3717A mutation of the proband was proved to have originated from paternal grandfather.

Family B. The pedigree of family B is shown in Fig. 1B. Two probands [B-11 (Patient 2) and B-12 (Patient 3)] are cousins to each other, and their maternal grandfather (B-1) had died of juvenile renal insufficiency at age 42 yrs. We identified a G3717A mutation in both probands (B-11 and B-12) that was inherited from each mother (B-9 and B-10), respectively, by taking into consideration of pedigree analysis results and their clinical histories, and estimated that the mutation containing the allele originated from B-1. Further, we estimated that the three polymorphisms (C-257T, A2089G, and G2881T) of their mother's eldest sister (B-3), who has intermittent episodes of recurrent renal insufficiency, were inherited from the other allele of B-1. The *FHI* in B-5 was not able to be determined.

B-4, B-6, B-7, and B-8 had already died of other causes.

Family C. The pedigree of family C is shown in Fig. 1C. Similar to the proband [C-6 (Patient 4)], her elder brother (C-4, 33-yr-old) and nephew (C-8, 7-yr-old) had been diagnosed as aHUS. However, their *FHI* were not able to be analyzed in present study. Her mother (C-2) had three heterozygous polymorphisms (C-257T, A2089G, and G2881T), but had no episodes of HUS. Her elder sister (C-3) inherited these three polymorphisms without episodes of HUS; whereas, the proband (C-6) did not inherit any of those polymorphisms.

Family D. The pedigree of family D is shown in Fig. 1D. The proband's mother (D-2) without episodes of HUS had three heterozygous polymorphisms (C-257T, A2089G, and G2881T). The proband [D-3 (Patient 5)] did not inherit any polymorphisms from her mother.

3.3. Biochemical characterization of factor H in aHUS patients

To characterize factor H in aHUS patients' sera biochemically, we performed immunoblot analysis using specific antibody against factor H. We detected the main band with a molecular weight of 150 kDa, corresponding to factor H protein, and the faint band with a molecular weight of 43 kDa, corresponding to factor H-like-protein 1 (Zipfel & Skerka, 1999; Ault, 2000), in all subjects. As well as in normal control, no extra band was observed in all subjects (data not shown).

Further, to investigate the function of factor H, we carried out the hemolytic assay using sheep erythrocytes as described in Materials and Methods. The reference value of the percent hemolytic activity was determined by making measurements of 32 healthy volunteers' sera. The individual differences in the percent hemolytic activities were minimum at 5% serum concentration among serum dilution series (CV, 14%); thus, we

defined the mean hemolytic activity at 5% serum concentration as a provisional reference value (mean \pm 2SD, $12 \pm 3\%$). We then compared the percent hemolytic activity of each patient's serum with the reference value. Five of 10 aHUS patients (Patient 1, 3, 6, 7, and 8) presented with a significantly high level of hemolytic activity (Fig.3). When we added recombinant factor H, with a final concentration of 1.1 mg/dl, significantly suppressed the accelerated hemolytic activities of 5 all patients (data not shown). Three of these 5 patients (Patient 1, 3, and 8) had mutation in exon 23 that encodes for SCR 20. Patient 4 had neither mutation nor polymorphism, despite having a low level of serum factor H. Patient 5 had three heterozygous polymorphisms, but no mutations, with a normal level of serum factor H. On the other hand, although Patient 2 had a mutation in exon 23, his hemolytic activity exhibited the normal level. Overall, no correlation between the hemolytic activity and factor H level was observed. The specificity of a hemolytic assay for the detection of aHUS was insufficient (50%), but the sensitivity was 100%.

3.5 Allele frequencies of factor H gene mutations and polymorphisms

To evaluate the effects of mutations and polymorphisms in *FHI* on the development of aHUS in Japanese, we compared the frequency of *FHI* mutations and polymorphisms in aHUS patients with that in healthy volunteers. As summarized in Table 4, no significant differences in the frequencies of all 6 disease risk polymorphisms, identified previously (Caprioli *et al*, 2003), were observed between aHUS patients and healthy volunteers. However, the mutations in exon 23 of *FHI* (A3717G or C3645T) were highly frequent, but not statistically significant, detected in aHUS patients (40%).

4. Discussion

In the present study, we identified *FHI* mutation in 4 of 10 aHUS patients. All of those mutations, located in exon 23 of *FHI*, encode SCR 20 (3 Arg1215Gln mutations and 1 Ser1191Leu mutation). Previous studies demonstrated that the majority of the mutations associated with aHUS are clustered at the SCR 20 in C-terminal end of factor H molecule, which plays a critical role as both C3 (C3d fragment)- and heparin-binding sites (Blackmore *et al*, 1998; Ault, 2000; Caprioli *et al*, 2001). Three of these patients presented with a significantly high level of hemolytic activity. The serum factor H level of Patient 1 was only modestly decreased, and those of Patient 3 and Patient 8 were increased rather than decreased. These findings supported the notion that those mutations in SCR 20 may impair the function of factor H in the alternative complement cascade on cell surface (Rodríguez de Córdoba *et al*, 2004) and subsequently cause the development of aHUS.

Hemolytic assays using sheep erythrocytes have been thought to be useful for the detection of factor H-related complement regulatory defects and molecular diagnosis of factor H-related aHUS (Sánchez-Corral *et al*, 2004). Notably, however, we revealed several discrepancies between the existence of the *FHI* mutation and the results of hemolytic assays in three cases. First, two patients (Patient 6 and Patient 7) presented with significantly high levels of hemolytic activity, even though they had no mutations in the well-known hot spot of *FHI*. In case of Patient 6, autoantibody may possibly interfere with the reaction on the quantification of serum factor H as described previously (Dragon-Durey *et al*, 2005; Józsi *et al*, 2007). It differed from Patient 6 with a low level of serum factor H, interestingly, Patient 7 presented with a normal level of serum factor H. Although we could not exclude the influence of some medical treatments (especially, plasma infusion) on specimens, used for the quantification of serum factor H, the addition of recombinant factor H

markedly improved hemolytic activities of both patients, providing compelling evidence that these patients have factor H-related complement regulatory defects, attributed to some variants in other region of *FHI*, which were not analyzed in present study. In general, mutations are categorized into the type I mutations with a significant reduction of the coded proteins and the type II mutations with an anomalous activity of the coded proteins. Our findings suggested that Patient 7 possibly carry some type II mutations. Second, despite the presence of Arg1215Gln mutation in SCR 20, one patient (Patient 2) presented with a normal or slightly high level of hemolytic activity. While the reduction of serum C3 in this patient arguably indicated that a complementary pathway was excessively activated, serum factor H level in this patient was slightly increased; thus, one possible reason for this discrepancy is that the dysfunction of innate factor H may cause up-regulation of factor H production, even an immature one. Further studies will be necessary to clarify the reason for these discrepancies.

We showed that 4 of 10 aHUS patients presented with normal levels of hemolytic activity and without any mutations in SCR 20. We could detect anti-factor H antibody in serum of Patient 10; therefore, autoantibody may possibly interfere with the reaction on the quantification of serum factor H. Although the pathogenesis of Patient 9 was difficult to interpret only by the results of the present study, those of other 2 patients (Patient 4 and 5) could be supposed to be caused by the reduction of serum factor H level. This finding suggests the possibility that the production of mature factor H protein might be impaired by some *FHI* abnormality, such as aberrations in alternative splicing, based on the mutation in the region of *FHI* introns. Atkinson *et al.* (2005) previously demonstrated that approximately 50% of patients with aHUS have a mutation in one of three genes, encoding factor H (20-30%), MCP (10-20%), or factor I (10-20%). Hence, we also should take account of the aberrations in other complementary regulatory factors, and so it will be

necessary to do additional experiments.

The results of pedigree analysis for family A and B also supported the notion that a mutation in the region of *FHI*, encoding SCR 20 of factor H, could be one of potent causative risk factors for the development of aHUS, although the proband's father (A-4) in family A and both probands' mother (B-9 and B-10) in family B had no episodes, even though they had this mutation. In contrast, we could not find any remarkable features in *FHI* in the pedigree analysis for family C and D. However, as described above, we cannot completely deny the factor H dysfunction, derived from some aberration of *FHI*. The marked reduction of serum factor H level in Patient 4 (C-6) leads to the above conclusions. In particular, despite having no episodes, her son (C-9) also presented with marked reduction of serum factor H level, suggesting that he might inherit some aberration of *FHI* (possibly some type I mutations in *FHI*) from his mother [Patient 4 (C-6)], but not any effects of autoantibodies. Furthermore, the clinical differences between Patient 4 (C-6) and her son (C-9) suggested that aberrations of *FHI* may not be an independent risk factor for aHUS. As described previously (Rodríguez de Córdoba *et al*, 2004; Noris & Remuzzi, 2009), other triggers may promote the development of aHUS. In fact, Patient 4 (C-6) had relapsed after pregnancy and partum. She also presented with an upper respiratory tract inflammation at relapse. These clinical findings were of importance to clarify the detailed pathogenic mechanism of aHUS.

Caprioli *et al*. (2003) and Neumann *et al*. (2003) previously reported that several polymorphisms in *FHI*, so-called disease risk polymorphisms, are frequently detected in aHUS patients more than healthy volunteers in Caucasians and German registries, respectively. We examined the allele frequencies of those disease risk polymorphisms in Japanese populations (See Materials and Methods). Of interest, no significant difference in frequency of disease risk polymorphisms was observed between healthy volunteers and

aHUS patients in Japanese groups, although the present study includes a limitation in that the results were obtained from small mass analyses. Previous studies (Blom *et al*, 2008; Martínez-Barricarte *et al*, 2008) have demonstrated racial differences in the relevance of a polymorphism in the C4b-binding protein, a regulator of the classical pathway of complementary activation, in the development of aHUS. Similarly, our findings suggest that ethnicity may affect the linkage between carrying the disease risk polymorphism in factor H and the development of aHUS.

In conclusion, our results are consistent with those of prior studies for other populations showing that *FHI* mutations relates to the development of Japanese aHUS; whereas, of interest, the well-known disease risk polymorphisms of *FHI* have been detected in most healthy Japanese. This finding suggested that some ‘second hit’ (e.g., a mutation in *FHI*, unknown polymorphisms in *FHI*, or variants of other complement regulatory factors) may be required for factor H polymorphism to be a risk factor of Japanese aHUS.

References

- Atkinson, J.P., Liszewski, M.K., Richards, A., Kavanagh, D., Moulton, E.A., 2005. Hemolytic uremic syndrome: an example of insufficient complement regulation on self-tissue. *Ann. N. Y. Acad. Sci.* **1056**, 144-152.
- Ault, B.H., 2000. Factor H and the pathogenesis of renal diseases. *Pediatr. Nephrol.* **14**, 1045-1053.
- Blackmore, T.K., Hellwage, J., Sadlon, T.A., Higgs, N., Zipfel, P.F., Ward, H.M., Gordon, D.L., 1998. Identification of the second heparin-binding domain in human complement factor H. *J. Immunol.* **160**, 3342-3348.
- Blom, A.M., Bergström, F., Edey, M., Diaz-Torres, M., Kavanagh, D., Lampe, A., Goodship, J.A., Strain, L., Moghal, N., McHugh, M., Inward, C., Tomson, C., Frémeaux-Bacchi, V., Villoutreix, B.O., Goodship, T.H.J., 2008. A novel non-synonymous polymorphism (p.Arg240His) in C4b-binding protein is associated with atypical hemolytic uremic syndrome and leads to impaired alternative pathway cofactor activity. *J. Immunol.* **180**, 6385-6391.
- Caprioli, J., Bettinaglio, P., Zipfel, P.F., Amadei, B., Daina, E., Gamba, S., Skerka, C., Marziliano, N., Remuzzi, G., Noris, M., 2001. The molecular basis of familial hemolytic uremic syndrome: mutation analysis of factor H gene reveals a hot spot in short consensus repeat 20. *J. Am. Soc. Nephrol.* **12**, 297-307.
- Caprioli, J., Castelletti, F., Bucchioni, S., Bettinaglio, P., Bresin, E., Pianetti, G., Gamba, S., Brioschi, S., Daina, E., Remuzzi, G., Noris, M., 2003. Complement factor H mutations and gene polymorphisms in haemolytic uraemic syndrome: the C-257T, the A2089G and the G2881T polymorphisms are strongly associated with the disease. *Hum. Mol. Genet.* **12**, 3385-3395.

- Caprioli, J., Noris, M., Brioschi, S., Pianetti, G., Castelletti, F., Bettinaglio, P., Mele, C., Bresin, E., Cassis, L., Gamba, S., Porrati, F., Bucchioni, S., Monteferrante, G., Fang, C.J., Liszewski, M.K., Kavanagh, D., Atkinson, J.P., Remuzzi, G., for the International Registry of Recurrent and Familial HUS/TTP., 2006. Genetics of HUS: the impact of MCP, CFH, and IF mutations on clinical presentation, response to treatment, and outcome. *Blood* **108**, 1267-1279.
- Delvaeye, M., Noris, M., De Vriese, A., Esmon, C.T., Esmon, N.L., Ferrell, G., Del-Favero, J., Plaisance, S., Claes, B., Lambrechts, D., Zoja, C., Remuzzi, G., Conway, E.M., 2009. Thrombomodulin mutations in atypical hemolytic-uremic syndrome. *N. Engl. J. Med.* **361**, 345-357.
- Dragon-Durey, M.A., Loirat, C., Cloarec, S., Macher, M.A., Blouin, J., Nivet, H., Weiss, L., Fridman, W.H., Frémeaux-Bacchi, V., 2005. Anti-factor H antibodies associated with atypical hemolytic uremic syndrome. *J. Am. Soc. Nephrol.* **16**, 555-563.
- Esparza-Gordillo, J., Goicoechea de Jorge, E., Buil, A., Carreras-Berges, L., López-Trascasa, M., Sánchez-Corral, P., Rodríguez de Córdoba, S., 2005. Predisposition to atypical hemolytic uremic syndrome involves the concurrence of different susceptibility alleles in the regulators of complement activation gene cluster in 1q32. *Hum. Mol. Genet.* **14**, 703-712.
- Ferreira, V.P., Pangburn, M.K., 2007. Factor H mediated cell surface protection from complement is critical for the survival of PNH erythrocytes. *Blood* **110**, 2190-2192.
- Józsi, M., Strobel, S., Dahse, H.M., Liu, W.S., Hoyer, P.F., Oppermann, M., Skerka, C., Zipfel, P.F., 2007. Anti factor H autoantibodies block C-terminal recognition function of factor H in hemolytic uremic syndrome. *Blood* **110**, 1516-1518.
- Karmali, M.A., Petric M., Lim, C., Fleming, P.C., Steele, B.T., 1983. *Escherichia coli* cytotoxin, haemolytic-uraemic syndrome, and haemorrhagic colitis. *Lancet* **322**,

1299-1300.

- Karmali, M.A., Petric, M., Lim, C., Fleming, P.C., Arbus, G.S., Lior, H., 1985. The association between idiopathic hemolytic uremic syndrome and infection by verotoxin-producing *Escherichia coli*. *J. Infect. Dis.* **151**, 775-782.
- Kaplan, B.S., Chesney, R.W., Drummond, K.N., 1975. Hemolytic uremic syndrome in families. *N. Engl. J. Med.* **292**, 1090-1093.
- Kaplan, B.S., Meyers, K.E., Schulman, S.L., 1998. The pathogenesis and treatment of hemolytic uremic syndrome. *J. Am. Soc. Nephrol.* **9**, 1126-1133.
- Martínez-Barricarte, R., Goicoechea de Jorge, E., Montes, T., Layana, A.G., Rodríguez de Córdoba, S., 2008. Lack of association between polymorphisms in C4b-binding protein and atypical haemolytic uraemic syndrome in the Spanish population. *Clin. Exp. Immunol.* **155**, 59-64.
- Neumann, H.P., Salzmann, M., Bohnert-Iwan, B., Mannuelian, T., Skerka, C., Lenk, D., Bender, B.U., Cybulla, M., Riegler, P., Königsrainer, A., Neyer, U., Bock, A., Widmer, U., Male, D.A., Franke, G., Zipfel, P.F., 2003. Haemolytic uraemic syndrome and mutations of the factor H gene: a registry-based study of German speaking countries. *J. Med. Genet.* **40**, 676-681.
- Noris, M., Remuzzi, G., 2009. Atypical hemolytic-uremic syndrome. *N. Engl. J. Med.* **361**, 1676-1687.
- Oppermann, M., Baumgarten, H., Brandt, E., Gottsleben, W., Kurts, C., Götze, O., 1990. Quantitation of components of the alternative pathway of complement (APC) by enzyme-linked immunosorbent assays. *J. Immunol. Methods* **133**, 181-190.
- Pangburn, M.K., Schreiber, R.D., Müller-Eberhard, H.J., 1977. Human complement C3b inactivator: isolation, characterization, and demonstration of an absolute requirement for the serum protein β 1H for cleavage of C3b and C4b in solution. *J. Exp. Med.* **146**,

257-270.

- Pangburn, M.K., 2002. Cutting edge: localization of the host recognition functions of complement factor H at the carboxyl-terminal: implications for hemolytic uremic syndrome. *J. Immunol.* **169**, 4702-4706.
- Richards, A., Buddles, M.R., Donne, R.L., Kaplan, B.S., Kirk, E., Venning, M.C., Tielemans, C.L., Goodship, J.A., Goodship, T.H.J., 2001. Factor H mutations in hemolytic uremic syndrome cluster in exons 18-20, a domain important for host cell recognition. *Am. J. Hum. Genet.* **68**, 485-490.
- Rodríguez de Córdoba, S., Esparza-Gordillo, J., Goicoechea de Jorge, E., Lopez-Trascasa, M., Sánchez-Corral, P., 2004. The human complement factor H: functional roles, genetic variations and disease associations. *Mol. Immunol.* **41**, 355-367.
- Rougier, N., Kazatchkine, M.D., Rougier, J.P., Fremeaux-Bacchi, V., Blouin, J., Deschenes, G., Soto, B., Baudouin, V., Pautard, B., Proesmans, W., Weiss, E., Weiss, L., 1998. Human complement factor H deficiency associated with hemolytic uremic syndrome. *J. Am. Soc. Nephrol.* **9**, 2318-2326.
- Sánchez-Corral, P., González-Rubio, C., Rodríguez de Córdoba, S., López-Trascasa, M., 2004. Functional analysis in serum from atypical hemolytic uremic syndrome patients reveals impaired protection of host cells associated with mutations in factor H. *Mol. Immunol.* **41**, 81-84.
- Sánchez-Corral, P., Melgosa, M., 2010. Advances in understanding the aetiology of atypical haemolytic uraemic syndrome. *Br. J. Haematol.* **150**, 529-542.
- Saunders, R.E., Goodship, T.H.J., Zipfel, P.F., Perkins, S.J., 2006. An interactive web database of factor H-associated hemolytic uremic syndrome mutations: insights into the structural consequences of disease-associated mutations. *Hum. Mutat.* **27**, 21-30.
- Scheiring, J., Rosales, A., Zimmerhackl, L.B., 2010. Clinical practice. Today's understanding

of the haemolytic uraemic syndrome. *Eur. J. Pediatr.* **169**, 7-13.

Weiler, J.M., Daha, M.R., Austen, K.F., Fearon, D.T., 1976. Control of the amplification convertase of complement by the plasma protein β 1H. *Proc. Natl. Acad. Sci. U S A.* **73**, 3268-3272.

Whaley, K., Ruddy, S., 1976. Modulation of the alternative complement pathway by β 1H globulin. *J. Exp. Med.* **144**, 1147-1163.

Zipfel, P.F., Skerka, C., 1999. FHL-1 / reconectin: a human complement and immune regulator with cell-adhesive function. *Immunol. Today* **20**, 135-140.

Figure Legends

Figure 1. Pedigree of families A, B, C, and D. We analyzed the data for mutations and polymorphisms in *FH1* as described in Materials and Methods. Arrows, probands; squares, men; circles, women; slashes, deceased; black asterisk, G3717A mutation; central black squares, carriers of G3717A mutation.

Figure 2. Hemolytic assay. Lysis of sheep erythrocytes by serum obtained from aHUS patients [solid circles, Patient 1 (with G3717A); open square, Patient 3 (with G3717A), solid square, Patient 6 (without mutation); triangles, Patient 7 (without mutation); crosses, Patient 8 (with C3645T mutation)]. The percent hemolytic activity of 32 healthy volunteers' sera shown (open circles) are mean + 2SD. (b) Inhibition of the lysis by factor H. We added recombinant factor H to each patients' serum to give final factor H concentrations of 1.1 mg/dl. Lysis (%) [with (shaded bars) or without (open bars) recombinant factor H] was determined at 5% serum concentration after a 30-min incubation. Data are expressed as mean \pm 2SD from duplicate determinations in each of three separate experiments. *: $P < 0.05$ and **: $P < 0.01$ compared with the lysis (%) of each patient serum without recombinant factor H.

Table 1. Primers set for factor H gene (FH1) screening

Region	SCR	Foward	Reverse
Promoter	-	5' – CAAGCACTGCATTCTTGGCA – 3'	5' – GCTAGGGAAATTCTCCGTTG – 3'
exon 7	SCR 5	5' – TTAAACGGATACTTATTTCTGCATTATCC – 3'	5' – TTCAGAATTAAGAAATGGGTCAAGATATG – 3'
exon 9	SCR 8	5' – ATAGATATTGAATGGGTTTATTTCTGAA – 3'	5' – GTTGAGCTGACCATCCATCTTTC – 3'
exon 14	SCR 11	5' – TATATTGTAAAACAGACAATTTAACC – 3'	5' – ATACAAAATACAAAAGTTTTGACAAG – 3'
exon 19	SCR 16	5' – GATGTCATAGTAGCTCCTGTATTGTTTATTT – 3'	5' – CCACTTACACTTTGAATGAAGAATATTTATC – 3'
exon 20	SCR 18	5' – CACTTCTTTTTTTTTCTATTCAGACACC – 3'	5' – AGAATTGAATTTTAAGCACCATCAG – 3'
exon 22	SCR 19	5' – TGAAATATCAGACTCATCACAGA – 3'	5' – ATACAGTGCTGTGTTTGCG – 3'
exon 23	SCR20 ^a	5' – GTTCTGAATAAAGGTGTGCAC – 3'	5' – GCCAAACAGAAGCTTTATTC – 3'
exon 23	SCR20 ^b	5' – CCCC GTTACACACAAATTCAA – 3'	5' – CTACATAGTTGGTTTGGAT – 3'

a, upstream region of exon 23. b, downstream region of exon 23.

Table 2. Clinical features of aHUS patients

Case (Pedigree No)	Age	Gender	Onset age	Clinical findings and evolutions
1 (A-6)	1 yr	F	4 mo	Renal insufficiency (BUN, 37 mg/dl; Cre, 2.01 mg/dl) and hypocomplementemia (C3*, 71 mg/dl) Under treatment (plasmapheresis and FFP administration).
2 (B-11)	34 yr	M	31 yr	Renal insufficiency (BUN, 54 mg/dl; Cre, 4.10 mg/dl), hemolytic anemia (Hb, 6.5 g/dl, LDH, 2200 U/L), bilirubinemia (Bil, 2.5 mg/dl), hypocomplementemia (C3, 57 mg/dl), and thrombocytopenia (Plt, $1.5 \times 10^4/\mu\text{l}$). Under treatment (Chronic hemodialysis and plasmapheresis).
3 (B-12)	38 yr	F	31 yr	Hypocomplementemia (C3, 67 mg/dl). Under treatment (Chronic hemodialysis).
4 (C-6)	29 yr	F	6 mo	Hemolytic anemia (Hb, 11.0 g/dl; LDH, 2083 U/L), and thrombocytopenia (Plt, $1.6 \times 10^4/\mu\text{l}$). C3 level was normal. Recurrence of aHUS after pregnancy and partum. Remission after PSL administration and steroid pulse therapy.
5 (D-3)	17 yr	F	13 yr	Renal insufficiency (BUN, 73 mg/dl; Cre, 4.30 mg/dl), hemolytic anemia (Hb, 7.6 g/dl; LDH, 2744 U/L), bilirubinemia (Bil, 6.4 mg/dl), and thrombocytopenia (Plt, $1.4 \times 10^4/\mu\text{l}$). C3 level was normal. Remission after continuous hemodialysis.
6	4 yr	F	n.c.	Renal insufficiency (BUN, 35 mg/dl; Cre, 4.79 mg/dl), hemolytic anemia (Hb, 8.7 g/dl; LDH, 1442 U/L), and thrombocytopenia (Plt, $4.9 \times 10^4/\mu\text{l}$). C3 level was normal. Under treatment (plasmapheresis).
7	8 yr	M	4 yr	Recurrence of aHUS after infection of influenzavirus B. Renal insufficiency (BUN, 55 mg/dl; Cre, 1.70 mg/dl), hemolytic anemia (Hb, 11.8 g/dl; LDH, 2547 U/L), bilirubinemia (Bil, 3.4 mg/dl), thrombocytopenia (Plt, $1.2 \times 10^4/\mu\text{l}$) and hypocomplementemia (C3, 50 mg/dl). Under supportive treatment.
8	40 yr	M	40 yr	Renal insufficiency (BUN, 106 mg/dl; Cre, 20.73 mg/dl), and hemolytic anemia (Hb, 5.0 g/dl; LDH, 2034 U/L) C3 level was normal. Under treatment (hemodialysis, plasmapheresis, PSL administration, and steroid pulse therapy).
9	7 yr	F	7 mo	Severe thrombocytopenia (Plt, $1.0 \times 10^4/\mu\text{l}$). C3 level was normal. Recurrence. Before treatment.
10	9 yr	F	n.c.	Renal insufficiency (BUN, 126 mg/dl; Cre, 2.90 mg/dl), hemolytic anemia (Hb, 5.2 g/dl; LDH, 4241 U/L), and thrombocytopenia (Plt, $5.5 \times 10^4/\mu\text{l}$) and hypocomplementemia (C3, 23 mg/dl). Before treatment.

*,C3 reference range (86.0-160 mg/dl);. Cre, creatinine; Bil, bilirubin; Plt, platelet; FFP, fresh frozen plasma; PSL, prednisolone; n.c., not clear.

Table 3. Factor H status in Japanese aHUS

Case (Pedigree No)	Polymorphisms						Mutation G3717A	Serum factor H levels (relative to normal value %) ^a	Hemolytic activity ^b	anti-factor H antibody
	C-257T	C994A	G1492A	A2089G	G2881T	G3364A				
1 (A-6)	CT	CC	GA	AG	GT	GG	AG	75*	+	-
2 (B-11)	CT	CA	GA	AG	GT	GG	AG	114*	-	-
3 (B-12)	CC	CA	GA	AA	GG	GG	AG	131*	+	-
4 (C-6)	CC	CC	AA	AA	GG	GG	GG	74*	-	-
5 (D-3)	CC	CC	AA	AA	GG	GG	GG	n.t.	-	-
6	CC	CC	AA	AA	GG	GG	GG	62*	+	+
7	CT	CA	n.d.	AA	GG	GA	GG	108	+	-
8	TT	CC	GA	GG	TT	GG	GG	143*	+	-
9	TT	CC	GG	GG	TT	GA	GG	125*	-	-
10	TT	CC	GG	GG	TT	GA	GG	80*	-	+

^a, Serum factor H levels were expressed as the relative to normal value (1388 ± 547 mg/l), determined by making measurements of healthy volunteers' sera.

* $p < 0.01$ vs normal value. ^b, The percent hemolytic activity of each patient's serum was compared with those of normal value, determined by making measurements of 32 healthy volunteers' sera as described in Materials and Methods. The subjects with a significantly high level of hemolytic activity were expressed as "positive". n.d., not determined. n.t., not tested.

Family A

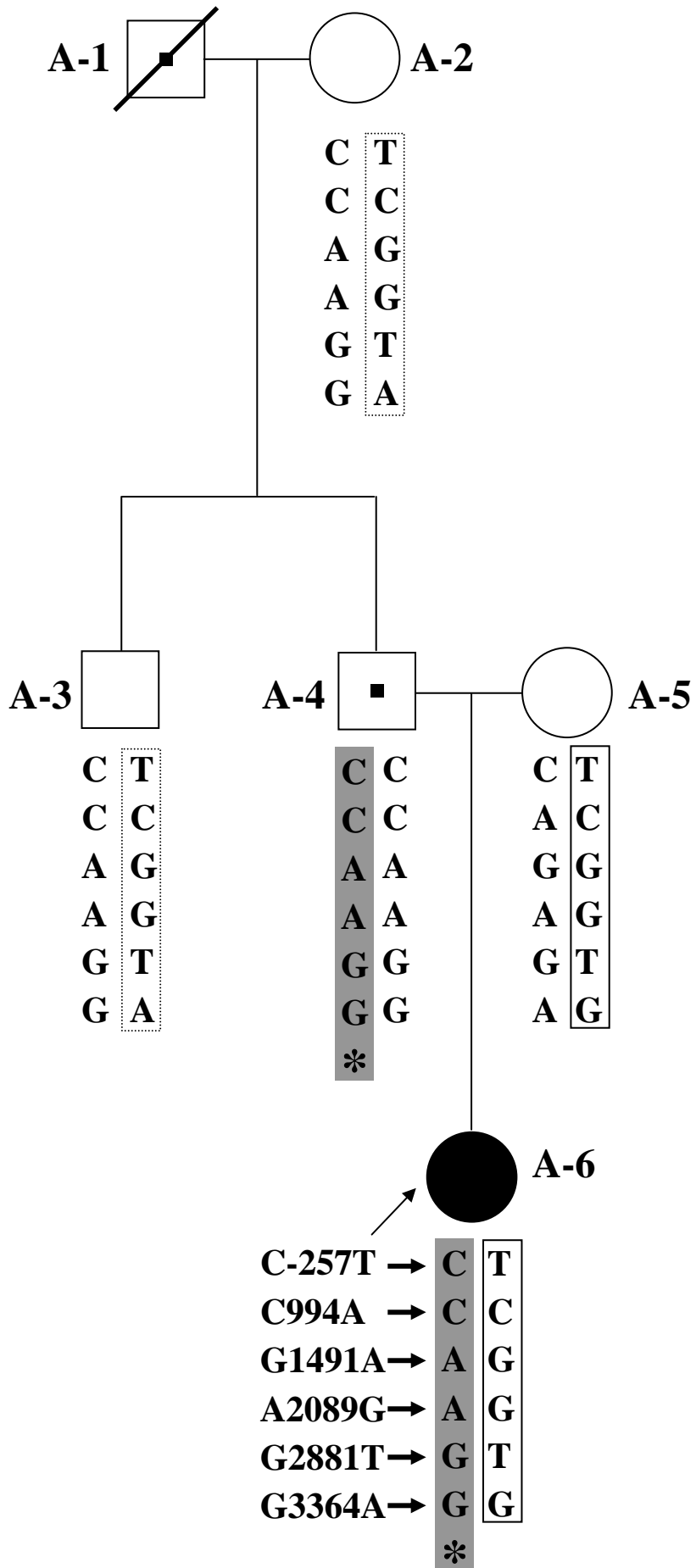

Figure 1-1

Family B

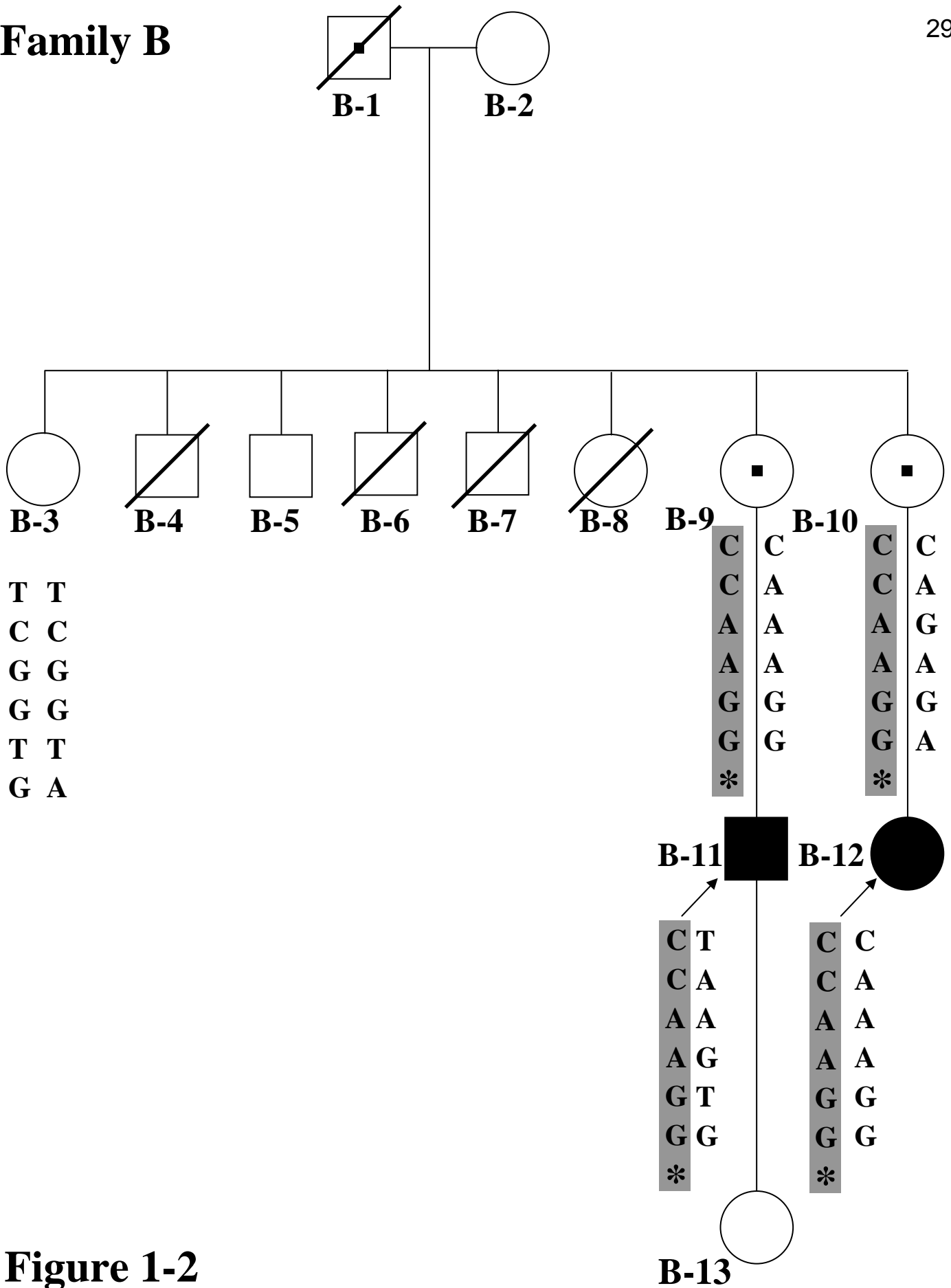

Figure 1-2

Family C

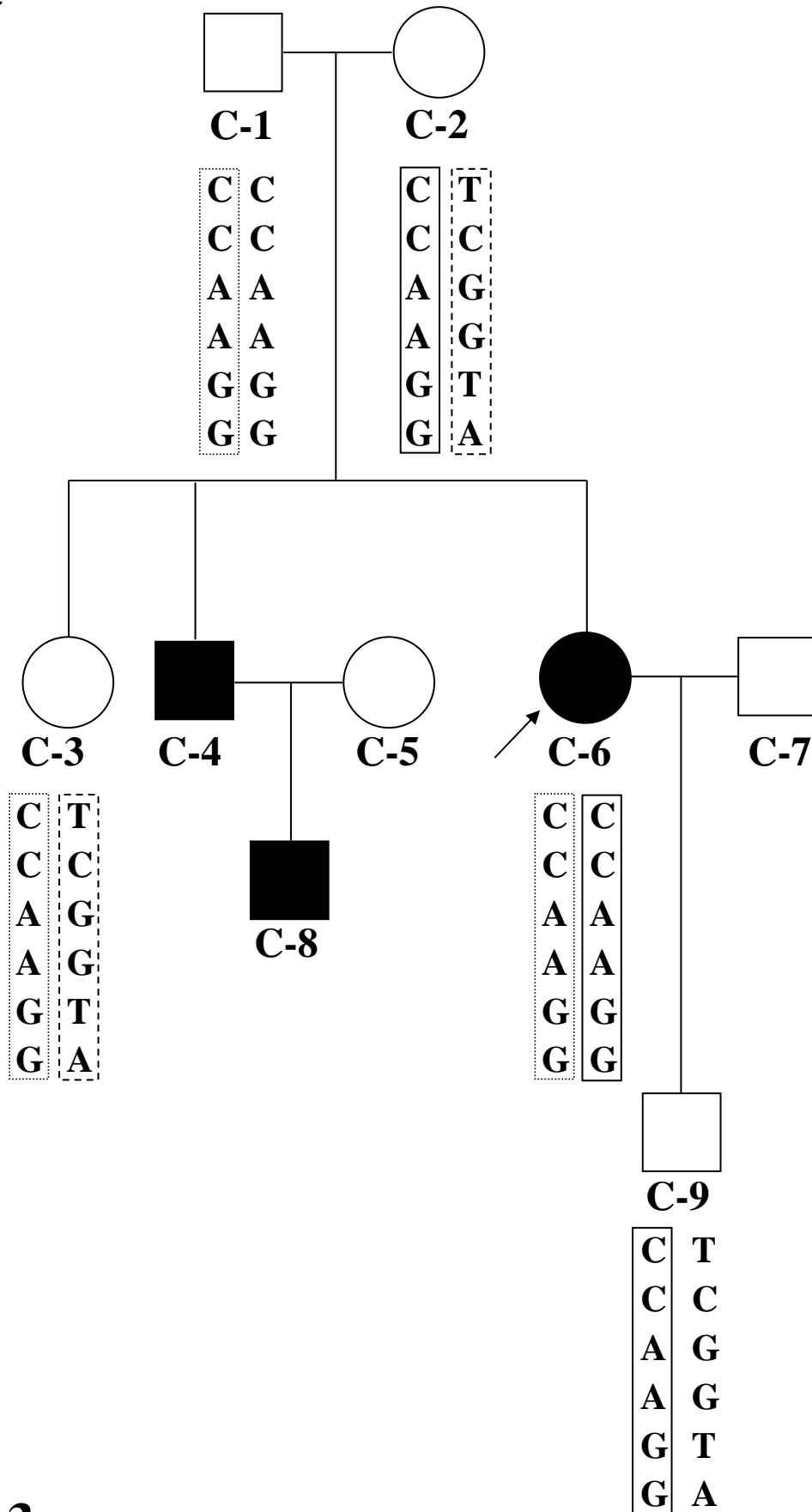
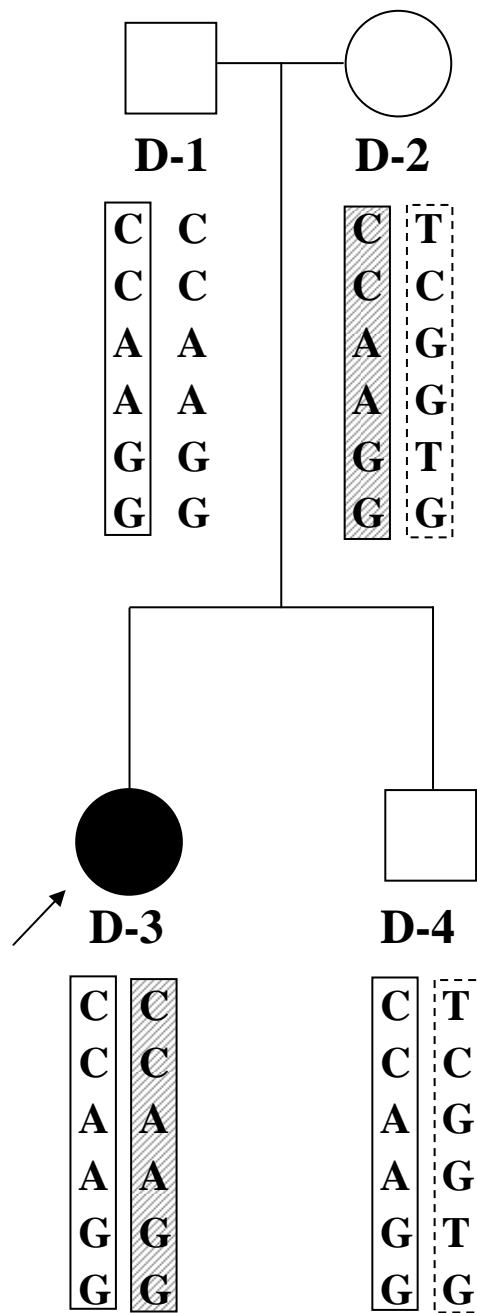

Figure 1-3

Family D



	proband
	deceased person
	carrier (G3717A)
	mutation (G3717A)

Figure 1-4

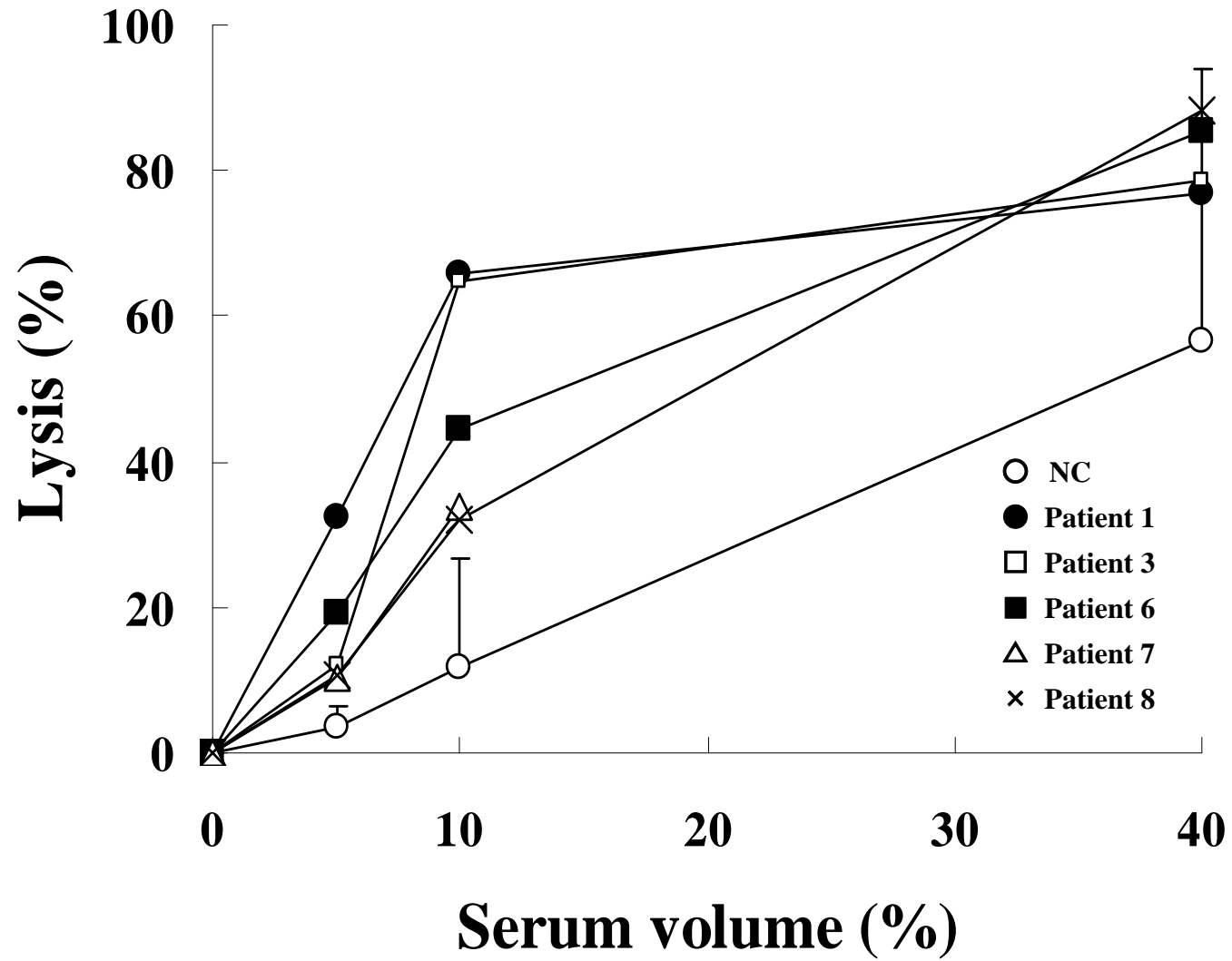

Figure 2