

DA00022
1979

The Monopole-Vortex Systems of Finite Size and
the Quark Confinement in the Nonabelian Gauge Theory

by

Masaru Kamata

Dissertation submitted to the Faculty of the Graduate School
of the University of Tsukuba in partial fulfilment
of the requirements for the degree of
Doctor of Science
January 1979

79701745

Abstract

Meson and Y-shaped and Δ -shaped baryon systems of finite size are constructed as the monopole-vortex systems in the nonabelian gauge models. These are natural generalizations of Nielsen and Olesen's solution of vortex of infinite length. The boundary conditions of Higgs scalars $\phi^{(i)}(\mathbf{x}) = F^{(i)} U(\mathbf{x})^{-1} T^{(i)} U(\mathbf{x})$, and $D_\mu \phi^{(i)}(\mathbf{x}) = 0$ are assumed at spatial infinity. $U(\mathbf{x})$ is the singular unitary matrix which is the one adopted by Arafune et al. for SU(2) case, and its SU(3) generalization. After the singular gauge transformation $U(\mathbf{x})$, the field tensor $F_{\mu\nu}$ acquires an additional nonzero term $-(i/e)U(\partial_\mu \partial_\nu - \partial_\nu \partial_\mu)U^{-1}$ which corresponds to Dirac's string term $G_{\mu\nu}^*$ for A_μ^3 and/or A_μ^8 vector potentials. These string singularities give the vortex solution of finite length. Our magnetic monopoles result from the field topology as in the 't Hooft-Polyakov monopole. The finite-size solutions in our SU(3) nonabelian gauge model enable us to construct the color-chemical-bond-like model for the quark confinement. Our solutions give a rigorous foundation to Nambu's conjecture on the quark confinement by vortex model. The possibility of construction of some exotic hadrons is also discussed.

Contents

§1. Introduction	1
§2. The Nielsen-Olesen U(1) model and the Nambu model	16
§3. The monopole-vortex systems in the Nielsen-Olesen SU(2) Higgs model	23
§3-1. A semi-infinite monopole-vortex system	23
§3-2. A finite monopole-vortex system	34
§4. The monopole-vortex systems in an SU(3) Higgs model	38
§4-1. Finite and semi-infinite monopole-vortex systems	38
§4-2. Y-shaped and Δ -shaped baryons	46
§5. Gauss' theorem on the squeezed magnetic flux	53
§6. The quark confinement in our SU(3) Higgs model	61
§7. Conclusion and final remarks	63
Appendix A: Notation	66
Appendix B: The unitary gauge of the SU(3) model of §4	67
References	71
Table Caption	
Figure Captions	
Tables	
Figures	

§1. Introduction

The various phenomena of hadron physics can be explained by quark model. But quarks have not been observed. Quarks are believed to be confined by SU(3) color^{1),2)} gauge fields. One of the most promising and simplest quark confinement model is the magnetic vortex model of nonabelian gauge field analogous to Landau-Ginzburg-Abrikosov model of superconductor. Nielsen and Olesen³⁾ presented vortex models of hadrons, which give string-like structure to the hadronic matter and also yield the confining force between quarks. It is quite unsatisfactory that their arguments are based on the solution of infinitely long vortex. Nambu^{4),5)} proposed a model, in which a mass term of the vector potential (London current) is added to Dirac's magnetic monopole theory⁶⁾:

$$\mathcal{L}_{Nambu} = \mathcal{L}_{Dirac} + \frac{1}{2} m_V^2 A_\mu^2, \quad (1.1)$$

and proved the long-range confining force between the monopoles (quarks). This model makes it possible to discuss the mesons of finite extent, but Nambu assumed the Dirac string singularities as a source, without the explanation of its singularities.

Brout et al.⁷⁾ presented another model for mesons, by introducing three Higgs scalars. The relation of this model to Nielsen and Olesen's one is unclear.

The aim of this paper is to show⁸⁾ the possibility of finite or semi-infinite monopole-vortex systems assuming no Dirac string

singularities in SU(2) and SU(3) nonabelian gauge models and furthermore to discuss the quark confinement in the hadron, especially to construct Y-shaped and Δ -shaped baryons. We impose the boundary condition for Higgs scalars at $r = \infty$, $\phi^{(i)}(\mathbf{x}) = F^{(i)} U^{-1}(\mathbf{x}) T^{(i)} U(\mathbf{x})$, where $U(\mathbf{x})$ is singular gauge transformation. The $U(\mathbf{x})$ corresponds to $\exp(i\mathbf{n}\varphi)$ of Nielsen-Olesen Model. We show that by the singular gauge transformation U the Dirac string singularity naturally appears as a result of the formula

$$(\partial_1 \partial_2 - \partial_2 \partial_1) \varphi (\equiv \tan^{-1}(y/x)) = 2\pi \delta(x) \delta(y). \quad (1.2)$$

Our model is a natural generalization of Nielsen and Olesen's model, and gives the mathematical foundation of Nambu's conjecture^{4),5)} on the quark confinement by vortex model. We show, in SU(3) case, that the baryon systems of Y (or Δ) shape can be constructed. Furthermore exotic systems such as a baryonium $q^2 \bar{q}^2$ can be also constructed similarly.

Our idea and general formulation for deriving the vortex solution of finite size is briefly summarized as follows. Consider the 't Hooft-Polyakov monopole⁹⁾, for example. The lines of magnetic force extend radially from the monopole to the infinities (Fig.1(a)). In the case of the monopole-antimonopole system¹⁰⁾, these lines originate from the monopole and terminate at the antimonopole (Fig.1(b)). Since the lines of magnetic force extend over the whole space and are not squeezed, vacuum of these systems is a normal one (i.e., not a superconducting vacuum)

The energy E of the monopole-antimonopole system is a decreasing function of the distance L between these poles. We can separate these poles far from each other by only finite energy. Therefore these monopole and antimonopole are not confined. In order to derive confining force between these poles, we must embed these systems into a superconducting vacuum, because in this vacuum the magnetic flux is squeezed and this squeezed magnetic flux tube (vortex line) leads to the confining force between these poles (Fig.2). The energies of these systems per unit length are constant: $E/L = \text{const.}$ (except for the vicinities of the end points). Thus we can get the linear confining potential $E = \text{const.} \times L$ for the monopole-antimonopole system of the distance L .

We now formulate the above idea by means of a suitable classical nonabelian gauge theory. The Lagrangian that we adopt is

$$\mathcal{L} = -\frac{1}{2} \text{Tr} F_{\mu\nu}^2 + \sum_{i=1}^K \text{Tr} D_{\mu} \Phi^{(i)} D^{\mu} \Phi^{(i)} - V(\Phi), \quad (1.3)$$

where $\Phi^{(i)}$ are K Higgs scalars. The number K of Higgs scalars is chosen so as to break spontaneously the gauge symmetry of (1.3) completely (complete Meissner effect). The Euler equations are

$$\begin{aligned} D^{\nu} F_{\mu\nu} &= -ie \sum_{i=1}^K [\Phi^{(i)}, D_{\mu} \Phi^{(i)}], \\ D^{\mu} D_{\mu} \Phi^{(i)} &= -\partial V / \partial \Phi^{(i)}, \quad i = 1, \dots, K, \end{aligned} \quad (1.4)$$

where $D_\mu \Phi^{(i)} = \partial_\mu \Phi^{(i)} - ie[A_\mu, \Phi^{(i)}]$. In order to solve the Euler equations (1.4), we impose boundary condition at $r = \infty$

$$\vec{\Phi}^{(i)}(x) = F^{(i)} U^{-1}(x) T^{(i)} U(x), \quad i = 1, \dots, K, \quad (1.5)$$

(no summation over i)

where $F^{(i)}$ are real number constants and to be determined by the minimum of Higgs potential. $U(x)$ is $SU(N)$ matrix which depends on x through certain angles, e.g., spherical angles θ and φ , and thus is singular transformation because of (1.2). $T^{(i)}$ are constant normalized generators, e.g., $T^{(i)} = \tau^i/2$ for $SU(2)$, $\lambda^i/2$ for $SU(3)$.

We see from simple energetic considerations that the Euler equations (1.4) have no static solution in the semi-infinite and finite monopole-vortex systems without any explicit external boundary condition (1.5). The dynamical solutions, however, may exist, e.g., for the rotating systems. In our model monopole or antimonopole of the system is assumed to be attached at the ends of vortex (or of the singular line of U) by the boundary condition (1.5). This boundary condition provides the superconductivity current which is necessary to enclose the vortex line of any shape. The number K of Higgs scalars, and the type of the matrices $T^{(i)}$ of (1.5) are chosen so as to produce vortices, otherwise 't Hooft-Polyakov-like monopole will be obtained, which will be unnecessary for the confinement. As explained later, it is quite important to choose an appropriate form of U in (1.5) in order to create the supercurrent which is necessary to preserve the vortex system of given shape. The choice of U

determines the shape of monopole-vortex system.

Furthermore, if needed, we impose the following ansatz for the Higgs scalars of $r \neq \infty$,

$$\Phi^{(i)}(x) = f^{(i)}(\rho, z) U^{-1}(x) T^{(i)} U(x), \quad i=1, \dots, K, \quad (1.6)$$

where $\rho \equiv (X^2 + Y^2)^{1/2}$ and $f^{(i)}$ are "form factors" and they approach the constant values $F^{(i)}$ at $r = \infty$. Some of the $\Phi^{(i)}$ (or $f^{(i)}$) must vanish on the singular line of $U(x)$ because of the continuity of $\Phi^{(i)}$ on this line. The $f^{(i)}$ are to be determined by Euler equations and their values near the vortex system must be solved numerically.

From the requirement of finiteness of the energy of the system, we must assure^{11), 12)}

$$D_\mu \Phi^{(i)}(x) = 0, \quad i=1, \dots, K \quad \text{at} \quad r = \infty. \quad (1.7)$$

After the transformation U , the condition (1.7) is reduced to $[T^{(i)}, A'_\mu] = 0$ which leads to $A'_\mu = 0$, provided that the gauge symmetry is completely broken (complete Meissner effect).

Therefore our boundary conditions at $r = \infty$ for the Higgs scalars and the gauge potential are summarized as follows

$$\begin{aligned} \Phi^{(i)}(x) &= F^{(i)} U^{-1}(x) T^{(i)} U(x), \quad i=1, \dots, K, \\ A^\mu(x) &= -\frac{i}{e} \partial^\mu U^{-1}(x) \cdot U(x), \end{aligned} \quad (1.8)$$

in original regular gauge and

$$\Phi^{(i)'}(x) = F^{(i)} T^{(i)}, \quad i=1, \dots, K, \quad (1.9)$$

$$A^{\mu'}(x) = 0,$$

in singular "vortex gauge", respectively.

It is most convenient to solve Euler equations (1.4) after the unitary transformation U . By this transformation, supercurrent (except for London current) $-ie \sum_{i=1}^K [\Phi^{(i)}, \partial_{\mu} \Phi^{(i)}]$ vanishes, but instead Dirac string appears. The transformed field tensor $F'_{\mu\nu}$ is

$$F_{\mu\nu} \xrightarrow{U} F'_{\mu\nu} = \partial_{\mu} A'_{\nu} - \partial_{\nu} A'_{\mu} - ie [A'_{\mu}, A'_{\nu}] + G_{\mu\nu}^*, \quad (1.10)$$

$$G_{\mu\nu}^* \equiv -\frac{i}{e} U [\partial_{\mu}, \partial_{\nu}] U^{-1},$$

where the last term $G_{\mu\nu}^*$ has in general Dirac string line, because of the singular nature of U , namely explicit φ dependence of U . String singularities are derived from the formula (1.2). Correspondingly transformed A'_{μ} has $1/\rho$ singularity along the center of vortex line, but original A_{μ} has no $1/\rho$ singularity, because the singularity of vortex and that of the pure gauge term $-(i/e) \partial^{\mu} U^{-1} \cdot U$ cancel each other¹⁰⁾. The Euler equations in the singular gauge are

$$D^{\nu} F'_{\mu\nu} = e^2 \sum_{i=1}^K [\Phi^{(i)'}, [\Phi^{(i)'}, A'_{\mu}]], \quad (1.11a)$$

$$D'_\mu D'^\mu \Phi^{(i)'} = -\partial V / \partial \Phi^{(i)'}, \quad i = 1, \dots, K. \quad (1.11b)$$

The solution must be obtained numerically. But its approximate solution can be obtained easily as follows. By assuming the minimum of Higgs potential for the Higgs scalars

$$\Phi^{(i)'}(x) = F^{(i)} T^{(i)}, \quad i = 1, \dots, K, \quad (1.12)$$

the Euler equation (1.11a) is written by

$$D'^\nu F_{\mu\nu}' = e^2 \sum_{i=1}^K F^{(i)2} [T^{(i)}, [T^{(i)}, A'_\mu]]. \quad (1.13)$$

The right-hand side of (1.13) gives the mass term of the gauge potential. For the singular gauge transformations that we shall adopt below, the tensor $G_{\mu\nu}^*$ is always diagonal matrix, e.g., $G_{12}^*(x) = (4\pi/e)(\tau^3/2)\delta(x)\delta(y)\theta(-z)$ for the $U(\theta, \varphi)$ of §3-1. Thus by setting

$$A'^\beta(x) = 0 \quad \beta = \text{off-diagonal components}, \quad (1.14)$$

in (1.13) we obtain

$$\partial^\nu (\partial_\mu A_\nu'^\alpha - \partial_\nu A_\mu'^\alpha + G_{\mu\nu}^{*\alpha}) = m_V^2(\alpha) A_\mu'^\alpha, \quad (1.15)$$

where α takes diagonal component(s), i.e., $\alpha = 3$ for $SU(2)$ and $\alpha = 3, 8$ for $SU(3)$. Gauge potentials with off-diagonal components

can be set equal to zero, because they have no string sources.

The $m_V(\alpha)$ is the mass of the gauge potentials A_μ^α and of the order $eF^{(i)}$. The equation (1.15) is easily solved as

$$A_0'^\alpha(x) = 0,$$

$$\vec{A}'^\alpha(x) = \frac{g_\alpha}{4\pi} \int_{\vec{b}}^{\vec{a}} d\vec{s} \times \vec{\nabla} \left\{ \frac{e^{-m_V(\alpha)|\vec{x}-\vec{s}|}}{|\vec{x}-\vec{s}|} \right\}, \quad (1.16)$$

$$\alpha = \text{diagonal component}(s)$$

where the Dirac monopole and antimonopole of the strength g_α are located at \vec{a} and \vec{b} respectively, and the line integral is taken along the singular line of $G_{\mu\nu}^*$. The A'_μ of (1.16) is vortex solution and its singular part is expressed by Dirac's formula

$$\vec{A}'^\alpha(x)_{\text{sing.}} = \frac{g_\alpha}{4\pi} \int_{\vec{b}}^{\vec{a}} d\vec{s} \times \vec{\nabla} \left(\frac{1}{|\vec{x}-\vec{s}|} \right), \quad (1.17)$$

which has the $1/\rho$ singularity along the singular line of $G_{\mu\nu}^*$. After performing the inverse transformation U^{-1} , we obtain the fields in the original gauge

$$\Phi^{(i)}(x) = F^{(i)} U^{-1}(x) T^{(i)} U(x), \quad i=1, \dots, K, \quad (1.18)$$

$$A^0(x) = 0,$$

$$\begin{aligned} \vec{A}(x) = & \sum_{\alpha=\text{diag.}} \frac{g_\alpha}{4\pi} U^{-1}(x) T^\alpha U(x) \cdot \int_{\vec{b}}^{\vec{a}} d\vec{s} \times \vec{\nabla} \left\{ \frac{e^{-m_V(\alpha)|\vec{x}-\vec{s}|}}{|\vec{x}-\vec{s}|} \right\} \\ & + \frac{i}{e} \vec{\nabla} U^{-1}(x) \cdot U(x), \end{aligned} \quad (1.19)$$

which has no $1/\rho$ singularity. The $1/\rho$ singularities cancel each other between the first and second terms on the right-hand side of (1.19)¹⁰⁾. The fields (1.18) and (1.19) are solutions of the Euler equations (1.11) under the assumption (1.12). These are also considered to be solutions in the region far away from the vortex line. The approximation (1.12) where the Higgs scalars take their vacuum expectation values over the whole space is justified in the "London approximation"⁷⁾, where $O(\lambda_S/\lambda_V) \ll 1$. Here the penetration length λ_V of the magnetic field and the coherence length λ_S of the Higgs scalars are defined by $\lambda_V = m_V^{-1}$ and $\lambda_S = m_S^{-1}$ respectively and the m_V and m_S are the typical masses of the A_μ and $\phi^{(i)}$ after the spontaneous symmetry breakdown.

The singular gauge transformations used in this paper, for U(1) and SU(2) cases, are (i) $U(\varphi) = e^{-in\varphi}$ for the infinite vortex-line system, (ii) $U(\theta, \varphi) = \exp(-i\varphi I_3) \exp(i\theta I_2) \exp(i\varphi I_3)$ for the semi-infinite monopole-vortex system and (iii) $U(\delta, \varphi) = \exp(-i\varphi I_3) \exp(i\delta I_2) \exp(i\varphi I_3)$ for the finite monopole-vortex system. The singular gauge transformations $U(\theta, \varphi)$ and $U(\delta, \varphi)$ were used by Arafune et al.¹⁰⁾ in order to find the "point solutions" for the 't Hooft-Polyakov monopole and monopole-antimonopole systems. Tze and Ezawa¹¹⁾ have already pointed out that the last term of $F'_{\mu\nu}$ of (1.10) is equal to $(2\pi n/e)\delta(x)\delta(y)$ in the case (i) of the singular gauge transformation $U(\varphi)$. In this paper we also show that the tensor $G_{\mu\nu}^*(x) \equiv -(i/e)U(\partial_\mu \partial_\nu - \partial_\nu \partial_\mu)U^{-1}$ is equal to $I_3(4\pi/e)\delta(x)\delta(y)\theta(-z)$ and $I_3(4\pi/e)\delta(x)\delta(y)\{\theta(a-z) - \theta(-a-z)\}$ for $U(\theta, \varphi)$ and $U(\delta, \varphi)$, respectively.

Furthermore, in SU(3) case, we introduce the following singular gauge transformations: (iv) $U(\theta, \varphi)$ and $U(\delta, \varphi)$ defined in §4-1 for the semi-infinite and finite monopole-vortex systems respectively, and (v) $S = U_1 \Gamma_1 U_2 \Gamma_2 U_3$ of §4-2 for the Y-shaped and Δ -shaped baryons, where $U_i(x) \equiv U(\delta^{(i)}, \varphi^{(i)})$ with the vertex angle $\delta^{(i)}$ of the triangle formed by the observed point and the two end points of the (i) vortex line of the system and the azimuthal angle $\varphi^{(i)}$ around this (i) vortex line (see Figs.7 and 8). Γ_1 and Γ_2 are suitable matrices. The $G_{\mu\nu}^*$ for $U(\delta, \varphi)$ of (iv) is $(2\pi/e) \{-3\beta(\lambda^3/2) + \sqrt{3}(\alpha-\gamma)(\lambda^8/2)\} \delta(x) \delta(y) \{\theta(a-z) - \theta(-a-z)\}$ and similar expressions are obtained for the $U(\theta, \varphi)$ of (iv) and the $S(x)$ of (v). The details will be presented in §4.

Our tensor $G_{\mu\nu}^*(x)$ corresponds to Dirac's one, which is introduced in his abelian magnetic monopole theory⁶⁾. It should be emphasized that Dirac introduced his tensor $G_{\mu\nu}^*$ explicitly in his magnetic monopole theory by hand but our $G_{\mu\nu}^*$ is derived from the non-commutativity of the derivative operations for the singular gauge transformation. Monopole or antimonopole source of our model is considered to be introduced externally through the singularity of the U matrix.

This paper is organized as follows. In §2, the infinite vortex-line system will be discussed. A relation between the Higgs current $ie(\phi^* \partial_\mu \phi - \phi \partial_\mu \phi^*)$ and the "Dirac current" $\partial^\nu G_{\mu\nu}^*$ under the singular gauge transformation $U(\varphi)$ is pointed out. At large distances, the Nielsen-Olesen U(1) model in the London approximation⁷⁾, with the aid of the singular gauge transformation $U(\varphi)$, yields the Nambu model of the infinite Dirac string with

strength of n Dirac units. We obtain the same expression for the gauge potential as that of Nielsen and Olesen, by transforming from "vortex gauge" to the original gauge.

In §3, semi-infinite and finite monopole-vortex systems will be constructed in the Nielsen-Olesen $SU(2)$ Higgs model³⁾. We adopt this model as one of the simplest nonabelian Higgs models from which the nonabelian vortex lines appear. This model has two isovector Higgs scalars $\vec{\phi}$ and $\vec{\psi}$. For the semi-infinite case of §3-1, our expressions for the Higgs scalars $\vec{\phi}$ and $\vec{\psi}$ are closely related with Mandelstam's homotopy¹³⁾. The parameter β in his homotopy is assumed to depend on the spatial coordinates, i.e., $\beta = \pi - \theta$ with the zenith angle θ . We investigate the behavior of fields near the axis of symmetry and at large distances from the vortex line. The Higgs scalars have the nodal lines on the negative z -axis and then we can check the complementarity¹¹⁾ of the Dirac strings and the nodal lines of the Higgs scalars. Furthermore we see that in the "vortex gauge", the Euler equation for A_{μ}^3 in the London approximation is identical with that of the Nambu model. The magnetic monopole at the end point of the vortex line have the strength of two Dirac units. There exists no Dirac string in our monopole-vortex system of the original regular gauge. A finite monopole vortex system of this model will be discussed in §3-2. Similar results as in §3-1 are obtained for this system, provided that the singular gauge transformation $U(\delta, \varphi)$ is used instead of $U(\theta, \varphi)$ in §3-1.

In §4, we shall extend the argument of §3 to the SU(3) gauge group. Finite and semi-infinite monopole-vortex systems in our SU(3) Higgs model are presented in §4-1. The potentials $A_{\mu}^{'3}$ and $A_{\mu}^{'8}$ of our "vortex gauge" have the Dirac string singularities with the strengths

$$g_3 \equiv \frac{2\pi}{e} \times 3\beta, \quad g_8 \equiv \frac{2\sqrt{3}\pi}{e} \times (\gamma - \alpha). \quad (1.20)$$

The α , β and γ are parameters which characterize the singular SU(3) gauge transformation $U(x)$ and have quantized values owing to the conditions

$$3\alpha, 3\beta, 3\gamma, \alpha - \beta, \beta - \gamma, \gamma - \alpha = \text{integers}, \quad (1.21)$$

which are derived from the single-valuedness of the Higgs scalars. Some of the nontrivial values of α , β and γ are listed in Tab. 1(a) and (b). We get two kinds of quantized magnetic vortex fluxes (charge) (1.20). But there is one difficulty that $A_{\mu}^{'3}$ and $A_{\mu}^{'8}$ are mixed by gauge transformation. In order to overcome this, we define the following gauge-invariant field strengths

$$2\text{Tr}(\hat{\Phi}^{(2)2} - \hat{\Phi}^{(3)2})F_{\mu\nu}, \quad \frac{2}{\sqrt{3}}\text{Tr}(2\hat{\Phi}^{(1)2} - \hat{\Phi}^{(2)2} - \hat{\Phi}^{(3)2})F_{\mu\nu}, \quad (1.22)$$

which are reduced to $F_{\mu\nu}^{'\alpha} = \partial_{\mu}A_{\nu}^{'\alpha} - \partial_{\nu}A_{\mu}^{'\alpha} + G_{\mu\nu}^{*\alpha}$, $\alpha = 3, 8$ in our "vortex gauge." The $\phi^{(i)}$ are the Higgs scalars in our SU(3) model and the $\hat{\Phi}^{(i)}$ are their suitably normalized fields. The $A \times A$ terms of $F_{\mu\nu}^{'\alpha}$ vanish, because only the diagonal components of the gauge potentials remain in our approximate solution in this gauge.

These terms can not be neglected in the exact solution, however. The field strengths (1.22) which we shall denote $\mathcal{F}_{\mu\nu}^I$ and $\mathcal{F}_{\mu\nu}^{II}$ can be used to define the magnetic fluxes of vortices or equivalently the magnetic charges of monopoles in a gauge-invariant way. 'Color' of monopoles (quarks) is defined by these I and II fluxes (Tables 1(a) and (b)). Red quark is defined by the one from which both vortices I and II originate. Blue quark is defined by the one into which vortex I comes and from which vortex II originates. Green quark is defined by the one into which vortex II of two units of fluxes comes. These two magnetic vortex fluxes give "chemical bonds" between red, blue, and green quarks (monopoles)^{5), 18)}. It is accidental that the 'color' of monopoles of Tab.1 coincides with the eigenvalues of λ^3 and λ^8 of SU(3) group. The origin of this 'color' is the topology of the fields. We shall denote this 'color' by adding quotation marks in order to discriminate it from the conventional color.^{1), 2)}

In §4-2, Y-shaped and Δ -shaped baryons are presented. As explained previously, we can introduce the singular SU(3) matrix $S(x)$ which gives desired Y- or Δ -shaped Dirac string singularities to the A_{μ}^3 and A_{μ}^8 gauge potentials in the "vortex gauge". In the Y-shaped baryon, the each sum of fluxes of the two kinds of magnetic vortices I and II is assumed to be zero at the junction of three vortices; otherwise we would not obtain genuine baryon system qqq . The Y-shaped baryon may be imagined to be constructed from the three meson systems $R\bar{R}$, $B\bar{B}$ and $G\bar{G}$ of §4-1 by gathering their three antimonopoles \bar{R} , \bar{B} and \bar{G} at the junction of this baryon system, where the each sum of the two magnetic charges of

\bar{R} , \bar{B} and \bar{G} must vanish (Fig.7). The difference between the Y-shaped and Δ -shaped baryons is pointed out.

In §5, we shall discuss Gauss' theorem on our squeezed magnetic flux. This is examined under the London approximation and in the "vortex gauge" of our models, where only the diagonal components of the gauge potentials remain. We can express the dual tensor $F_{\mu\nu}^*$, where $F_{\mu\nu} = \partial_\mu A_\nu - \partial_\nu A_\mu + G_{\mu\nu}^*$ for $A_\mu \equiv A_\mu^3$ or A_μ^8 , in a transparent form for physical insight. We see that the magnetic flux originates from the monopole in two distinct forms. For the semi-infinite system of §3-1, for example, one extends to infinity in the form of squeezed flux tube of radius m_V^{-1} along the negative z-axis. The other part extends from the origin spherically like Yukawa force with the range m_V^{-1} . For $r \gg m_V^{-1}$, the latter part vanishes, but the former extends to infinity and presents the origin of confining force between quarks. Magnetic flux Φ of the squeezed flux tube is equal to the magnetic charge g of the monopole at the origin, i.e., $\Phi = -g$ in our notation. Similar results can be obtained for the systems of §§3-2 and 4-1.

In §6, the quark confinement will be discussed in our SU(3) Higgs model. Our I and II vortex lines correspond to the vortex bonds of Nambu's phenomenological chemical bond model for hadrons^{5),18)}. These bonds allow only 'colorless' states such as $R\bar{R}$, $B\bar{B}$ and $G\bar{G}$ meson systems and RBG baryon system as finite-energy states. By 'colorless' states, we shall mean such systems with no magnetic 'color' charge. The allowed states in our SU(3) model are

- (i) 'colorless' mesons: $R\bar{R}$, $B\bar{B}$, $G\bar{G}$,
- (ii) 'colorless' baryon (antibaryon): RBG ($\bar{R}\bar{B}\bar{G}$),

- (iii) 'colorless' exotic states: $R\bar{R}\bar{B}\bar{B}$, $R^2B^2G^2$ etc. (Fig.10),
- (iv) Pomeron⁵⁾ (Fig.11).

It is interesting to note that some exotic states are allowed in our model. All the other systems such as 'colored' mesons, 'colored' baryons, diquarks, isolated quarks, and 'colored' exotic states, e.g., $RRBB$ are excluded in our model. We see that the confinement of quarks, in this chemical vortex bond model, can be explained at least for 'colorless' states, but does not necessarily select the 'color' singlet hadron states. It is interesting to study experimentally the difference between the 'colorless' states in our model and the color singlet states in the conventional color model. Further analysis is required on this point.

The last section, §7, is devoted to conclusion and some final remarks.

§2. The Nielsen-Olesen U(1) model and the Nambu model^{8),*)}

In the Nielsen-Olesen U(1) model³⁾ the Lagrangian is given by

$$\begin{aligned} \mathcal{L} &= -\frac{1}{4}(\partial_\mu A_\nu - \partial_\nu A_\mu)^2 + |(\partial_\mu - ieA_\mu)\phi|^2 - V(\phi), \\ V(\phi) &= \mu^2|\phi|^2 + \frac{\lambda}{2}|\phi|^4. \quad (\mu^2 < 0, \lambda > 0) \end{aligned} \quad (2.1)$$

The Euler equations for the gauge potential A_μ and the complex Higgs scalar ϕ are

$$\partial^\nu(\partial_\mu A_\nu - \partial_\nu A_\mu) = ie(\phi^* \partial_\mu \phi - \phi \partial_\mu \phi^*) + 2e^2 |\phi|^2 A_\mu, \quad (2.2)$$

$$(\partial_\mu - ieA_\mu)^2 \phi = -\mu^2 \phi - \lambda |\phi|^2 \phi. \quad (2.3)$$

The Nielsen-Olesen ansatz for ϕ and A_μ is $\phi(x) = \exp(in\varphi)f(\rho)$, $A^0(x) = 0$ and $\vec{A}(x) = \vec{e}_\varphi g(\rho)$, where φ is the azimuthal angle, \vec{e}_φ is the unit vector in the direction of φ and n is an integer. The $f(\rho)$ and $g(\rho)$ are real functions of $\rho \equiv (x^2 + y^2)^{1/2}$. Substitution of this ansatz into (2.2) and (2.3) leads to differential equations for $f(\rho)$ and $g(\rho)$. This is Nielsen and Olesen's procedure.

We now apply our general method summarized in §1 to the

*) The term "singular gauge" used in §§2 and 3 may also be substituted by "vortex gauge". The latter will be used in §4 and the subsequent sections.

simplest Higgs model (2.1). We take the same ansatz for the Higgs scalar ϕ as Nielsen and Olesen's one: $\phi(x) = \exp(in\varphi)f(\rho)$. We remove the phase factor $\exp(in\varphi)$ of ϕ through the singular gauge transformation^{*)} $U(\varphi) = \exp(-in\varphi)$, so that the real Higgs scalar $\phi' = f(\rho)$ is obtained and the Higgs current vanishes. The transformation $U(\varphi)$, however, yields a new term $G_{\mu\nu}^*(x)$ to the Euler equations (2.2):

$$\partial^\nu(\partial_\mu A'_\nu - \partial_\nu A'_\mu) = \partial^\nu G_{\nu\mu}^* + 2e^2 f^2 A'_\mu, \quad (2.4)$$

$$(\square - e^2 A'_\mu A'^\mu) f = -\mu^2 f - \lambda f^3, \quad (2.5)$$

where

$$A'_\mu = A_\mu - (i/e) \partial_\mu U \cdot U^{-1} = A_\mu - (n/e) \partial_\mu \varphi, \quad (2.6)$$

$$G_{\mu\nu}^* \equiv -\frac{i}{e} U (\partial_\mu \partial_\nu - \partial_\nu \partial_\mu) U^{-1} = \frac{n}{e} (\partial_\mu \partial_\nu - \partial_\nu \partial_\mu) \varphi.$$

The nonzero components of $G_{\mu\nu}^*$ are given by

$$G_{12}^*(x) = -G_{21}^*(x) = \frac{2\pi n}{e} \delta(x) \delta(y), \quad (2.7)$$

*) By singular gauge transformation, we shall mean gauge transformation U for which $\partial_\mu \partial_\nu U = \partial_\nu \partial_\mu U$ fails to hold on lines or points.

where we have used the following relation:

$$\vec{\nabla} \cdot \frac{\vec{\rho}}{\rho^2} = 2\pi \delta(x)\delta(y), \quad \vec{\rho} \equiv (x, y, 0). \quad (2.8)$$

We see that the vector $\vec{\rho}/\rho^2$ is divergenceless outside the z-axis. In order to estimate the $\vec{\nabla} \cdot (\vec{\rho}/\rho^2)$ on the z-axis, we integrate it over the xy-plane: $\int dx dy \vec{\nabla} \cdot (\vec{\rho}/\rho^2) = \oint d\varphi = 2\pi$, thus (2.8) is obtained. A more rigorous treatment will be provided with the distribution theory. See Ref. 14), for example.

The tensor $G_{\mu\nu}$ which has nonzero components $G_{03} = -G_{30} (= G_{12}^*)$ can be expressed in terms of Dirac's string variables $y^\mu = y^\mu(\tau, \sigma)$:

$$G^{\mu\nu}(x) = g \int_{-\infty}^{\infty} d\tau \int_{-\infty}^{\infty} d\sigma [y^\mu, y^\nu] \delta^4(x-y), \quad (2.9)$$

$$[y^\mu, y^\nu] \equiv \frac{\partial y^\mu}{\partial \tau} \frac{\partial y^\nu}{\partial \sigma} - \frac{\partial y^\mu}{\partial \sigma} \frac{\partial y^\nu}{\partial \tau}$$

with $y^0 = \tau$, $y^1 = y^2 = 0$, $y^3 = \sigma$, and $g = -2\pi n/e$ (n Dirac units).

The tensor $G_{\mu\nu}^*$ in (2.4) can be regarded as the one derived from the Dirac string extended on the z-axis from $z = -\infty$ to $z = \infty$.

Applying Patkós' argument¹⁵⁾ to (2.4) and (2.5), we see that the Higgs scalar $\phi' = |\phi|$ has the zeros on the whole z-axis, which implies the continuity on the z-axis of the Higgs scalar $\phi = \exp(in\varphi) |\phi|$ in the regular gauge. Furthermore the complementarity¹¹⁾ of the Dirac strings in the singular gauge and the nodal lines of the Higgs scalars is satisfied.

Compared (2.4) with (2.2), we find that the Higgs current $ie(\phi^* \partial_\mu \phi - \phi \partial_\mu \phi^*)$ in (2.2) is exactly replaced by the "Dirac current"

$\partial^\nu G_{\nu\mu}^*$ in (2.4). Note that the Dirac current $\partial^\nu G_{\nu\mu}^*$ is nonzero only in the infinitesimal region around the z-axis (the infinitesimal solenoidal current) and, in contrast, the Higgs current is not so.

Next we investigate the behavior of A'_μ at large distances from the vortex line. In the temporal gauge $A'_0 = 0$, the equation (2.4) yields the following integral equation for A'_i :

$$A'_i(\vec{x}) = - \int G(\vec{x}-\vec{x}') \partial^j G_{ji}^*(x') d\vec{x}' + 2e^2 \int G(\vec{x}-\vec{x}') \{ |\phi(\infty)|^2 - |\phi(\vec{x}')|^2 \} A'_i(\vec{x}') d\vec{x}', \quad (2.10)$$

where we have imposed the condition $\vec{\nabla} \cdot \vec{A}' = 0$, which will be proved later to be consistent with our final result for A'_μ ^{*)}. The function $G(\vec{x}-\vec{x}') = (1/4\pi) \{ \exp(-m_V |\vec{x}-\vec{x}'|) / |\vec{x}-\vec{x}'| \}$ is the Green function for the massive vector field with mass $m_V = eF$, in which F is defined by $|\phi(\infty)| = F/\sqrt{2}$. The integral equation (2.10) can be solved, formally, by the iteration. This iterative expansion is justified for large distances $\rho \gg m_V^{-1}$ and in the London approximation ^{**)} as

*) In the derivation of (2.10) we have assumed the relation $[\partial^\mu, \partial^\nu] A'_\nu = 0$. Its justification is given by single valuedness of A'_ν with respect to the space-time point x^μ , see Ref. 16).

***) According to Brout et al. ⁷⁾, we refer to the neglect of the terms $O(m_V/m_S) = O(\lambda_S/\lambda_V)$ as the "London approximation". Here m_V and m_S are the masses of A'_μ and ϕ after the spontaneous symmetry breakdown; $m_V = e(-2\mu^2/\lambda)^{1/2}$, $m_S = (-4\mu^2)^{1/2}$. The penetration length λ_V of the magnetic field and the coherence length λ_S of the Higgs scalar ϕ are defined by $\lambda_V = m_V^{-1}$ and $\lambda_S = m_S^{-1}$, respectively.

shown in the following.

The first zeroth-order term of the right-hand side of (2.10) is equal to the gauge potential in the Nambu model^{4),7)}

$$\vec{A}'(\vec{x})^{(0)} = \frac{n}{2e} \int_{-\infty}^{\infty} d\vec{s}' \cdot \vec{x} \nabla' \left\{ \frac{-\exp(-m_{\nabla} |\vec{x} - \vec{x}'|)}{|\vec{x} - \vec{x}'|} \right\} = \vec{e}_{\varphi} \frac{n}{e} m_{\nabla} K_1(m_{\nabla} \rho), \quad (2.11)$$

where the line integral is taken along the whole z-axis. After iteration the first-order term for A_i' is obtained as

$$\vec{A}'(\vec{x})^{(1)} = \frac{n}{e} m_{\nabla} \times \frac{e^2}{\pi} \int \left\{ |\phi(\infty)|^2 - |\phi(\vec{x}')|^2 \right\} K_0(m_{\nabla} \tilde{\rho}) K_1(m_{\nabla} \rho') \vec{e}_{\varphi}' dx'^1 dx'^2, \quad (2.12)$$

where $\rho' = |\vec{\rho}'|$, $\vec{\rho}' = (x'^1, x'^2, 0)$ and $\tilde{\rho} = |\vec{\rho} - \vec{\rho}'|$. The magnitude of the Higgs scalar $|\phi(\vec{x}')|$ differs from its vacuum expectation value only in the region of $0 \leq \rho' \leq \lambda_S$. Therefore we can roughly estimate the integral in (2.12) by approximating the difference $|\phi(\infty)|^2 - |\phi(\vec{x}')|^2$ by the step function $|\phi(\infty)|^2 \theta(\lambda_S - \rho')$:

$$\vec{A}'(\vec{x})^{(1)} \cong \frac{n}{e} m_{\nabla} \cdot \frac{e^2}{\pi} |\phi(\infty)|^2 \int_{0 \leq \rho' \leq \lambda_S} K_0(m_{\nabla} \tilde{\rho}) K_1(m_{\nabla} \rho') \vec{e}_{\varphi}' dx'^1 dx'^2. \quad (2.13)$$

Since the condition $\rho \gg \lambda_{\nabla} \gg \lambda_S$ is satisfied at large distances and under the London approximation, we get

$$\vec{A}'(\vec{x})^{(1)} \cong \vec{e}_\varphi \frac{n}{e} m_\nu K_1(m_\nu \rho) \times \frac{1}{4} \left(\frac{\lambda_S}{\lambda_\nu} \right)^2, \quad (2.14)$$

where we have replaced $K_1(m_\nu \rho')$ of (2.13) by its most dominant part $(m_\nu \rho')^{-1}$. From (2.11) and (2.14) we obtain

$$\begin{aligned} \vec{A}'(\vec{x}) &= \vec{A}'(\vec{x})^{(0)} + \vec{A}'(\vec{x})^{(1)} \\ &\cong \vec{e}_\varphi \frac{n}{e} m_\nu K_1(m_\nu \rho) \left\{ 1 + O((\lambda_S/\lambda_\nu)^2) \right\} \end{aligned} \quad (2.15)$$

up to the first order of $\vec{A}'(\vec{x})$. Thus it is justified to solve (2.10) iteratively for large distances and in the London approximation^{*)}. We conclude that, for large distances and in the London approximation, the Nielsen-Olesen U(1) model in the singular gauge ((2.4) and (2.5)) can be approximated by the Nambu model

$$\partial^\nu (\partial_\mu A'_\nu - \partial_\nu A'_\mu + G_{\mu\nu}^*) = m_\nu^2 A'_\mu \quad (2.16)$$

and the constant Higgs scalar $\phi' = F/\sqrt{2}$.

Finally we show that if we perform the inverse transformation

*) We may expect, say, a term of the order of magnitude $(\lambda_S/\lambda_\nu) \ln(\lambda_S/\lambda_\nu)$ in the higher-order expansion of (2.10), but they do not change the result of (2.15) under the London approximation.

$U^{-1}(\varphi)$ to the solution (2.11), we get the same expression that Nielsen and Olesen obtained by treating $|\phi|$ as a constant. After performing $U^{-1}(\varphi)$ to the vector potential (2.11), we get

$$\vec{A}(\vec{x}) = \vec{e}_\varphi \left\{ -\frac{n}{e\rho} + \frac{n}{e} m_\nabla K_1(m_\nabla \rho) \right\}, \quad (2.17)$$

and the Higgs scalar is $\phi(\mathbf{x}) = (F/\sqrt{2}) \exp(in\varphi)$. This is the result of Nielsen and Olesen: They obtained (2.17) by solving the Euler equation (2.2) in which $|\phi|$ is treated as a constant. We could reproduce the same result as that of Nielsen and Olesen through a different path from them, which indicates the consistency of our treatment of the singular gauge transformations.

§3. The monopole-vortex systems in the Nielsen-Olesen SU(2) Higgs model⁸⁾

§3-1. A semi-infinite monopole-vortex system

We now deal with the semi-infinite monopole-vortex system. Our method in §2 can also be applied to this system. We adopt the Nielsen-Olesen SU(2) Higgs model³⁾, which contains two isovector Higgs scalars $\vec{\phi}$ and $\vec{\psi}^*$). The Lagrangian is given by

$$\mathcal{L} = -\frac{1}{2} \text{Tr} F_{\mu\nu}^2 + \text{Tr} D_\mu \phi D^\mu \phi + \text{Tr} D_\mu \psi D^\mu \psi - V(\phi, \psi),$$

$$V(\phi, \psi) = 2c_2 \text{Tr} \phi^2 + 4c_4 (\text{Tr} \phi^2)^2 + 2d_2 \text{Tr} \psi^2 + 4d_4 (\text{Tr} \psi^2)^2 + 2e_2 \text{Tr} \phi \psi + 4e_4 (\text{Tr} \phi \psi)^2. \quad (3-1.1)$$

$$(c_2, d_2 < 0, c_4, d_4, e_4 > 0)$$

*) Brout et al. chose a multiscalar model⁷⁾ containing three Higgs scalars $\vec{\varphi}_i$, for convenience. However, in SU(2) case only two Higgs scalars with noncollinear vacuum expectation values³⁾ are sufficient for deriving the vortex line. This is the reason for our choice of the model (3-1.1). Higgs scalars $\vec{\varphi}_i$ (or $\vec{\psi}$ and $\vec{\chi}$) of Ref. 7) which vary in space keeping a pyramidal symmetry in their ground states are replaced by (3-1.4) in this paper which varies in space keeping the configuration (3-1.5) with fixed relative angle φ_0 .

Here $V(\phi, \psi)$ is the Higgs potential and the Euler equations are

$$D^\nu F_{\mu\nu} = -ie[\phi, D_\mu\phi] - ie[\psi, D_\mu\psi], \quad (3-1.2)$$

$$D^\mu D_\mu\phi = -\frac{\partial V}{\partial\phi}, \quad D^\mu D_\mu\psi = -\frac{\partial V}{\partial\psi}, \quad (3-1.3)$$

where $F_{\mu\nu} = \partial_\mu A_\nu - \partial_\nu A_\mu - ie[A_\mu, A_\nu]$, $D_\mu\phi = \partial_\mu\phi - ie[A_\mu, \phi]$,
 $A_\mu = (\tau^a/2)A_\mu^a$ etc. and $\vec{\tau}$ are the Pauli matrices.

Consider a static axially symmetric semi-infinite vortex line whose energy is localized about the negative z-axis (Fig.3). Correspondingly we propose the following ansatz for the Higgs scalars $\vec{\phi}$ and $\vec{\psi}$:

$$\begin{aligned} \vec{\phi}(x) &= \{ \cos\theta \cos^2\varphi + \sin^2\varphi, (\cos\theta - 1)\cos\varphi\sin\varphi, -\sin\theta\cos\varphi \} f_\phi(\rho, z), \\ \vec{\psi}(x) &= \{ \cos\theta \cos\varphi \cos(\varphi - \varphi_0) + \sin\varphi \sin(\varphi - \varphi_0), \\ &\quad \cos\theta \sin\varphi \cos(\varphi - \varphi_0) - \cos\varphi \sin(\varphi - \varphi_0), \\ &\quad -\sin\theta \cos(\varphi - \varphi_0) \} f_\psi(\rho, z), \end{aligned} \quad (3-1.4)$$

where θ is the zenith angle. Here φ_0 is a constant determined from the Higgs potential $V(\phi, \psi)$, and we assume to be $\varphi_0 \neq 0, \pi^3$. The f_ϕ and f_ψ are some functions (the "form factors"). In (3-1.4), we have explicitly fixed only the directions of the Higgs scalars in the isospin space and left their magnitudes, i.e., f_ϕ and f_ψ unfixed. But these f_ϕ and f_ψ are chosen so as

to satisfy the suitable boundary conditions compatible with this vortex line.

The Higgs scalars in our singular gauge are expressed as

$$\begin{aligned}\vec{\phi}'(x) &= (1, 0, 0)f_{\phi}(\rho, z), \\ \vec{\psi}'(x) &= (\cos\varphi_0, \sin\varphi_0, 0)f_{\psi}(\rho, z).\end{aligned}\tag{3-1.5}$$

The above Higgs scalars (3-1.5) are connected with those of (3-1.4) in the regular gauge through the singular gauge transformation $U(\theta, \varphi)^{10) = \exp(-i\varphi I_3)\exp(i\theta I_2)\exp(i\varphi I_3)$, i.e., $\phi = U^{-1}(\theta, \varphi)\phi'U(\theta, \varphi)$ and $\psi = U^{-1}(\theta, \varphi)\psi'U(\theta, \varphi)$. The Higgs scalars $\vec{\phi}'$ and $\vec{\psi}'$ lead to the vanishing Higgs currents; $-ie[\phi', \partial_{\mu}\phi'] = -ie[\psi', \partial_{\mu}\psi'] = 0$, and this is one of the reasons for our choice of the ansatz (3-1.4). Note that $\vec{\phi}'$ and $\vec{\psi}'$ are on the 12-plane in the isospin space and the angle between them is the constant φ_0 .

On the positive z-axis, the Higgs scalars $\vec{\phi}$ and $\vec{\psi}$ of (3-1.4) agree with those of (3-1.5) having constant directions in the isospin space. On the other hand, the Higgs scalars around the vortex line near $z = -\infty$ are

$$\begin{aligned}\vec{\phi}(x)|_{\theta=\pi} &= (-\cos 2\varphi, -\sin 2\varphi, 0)f_{\phi}(\rho, z), \\ \vec{\psi}(x)|_{\theta=\pi} &= (-\cos(2\varphi - \varphi_0), -\sin(2\varphi - \varphi_0), 0)f_{\psi}(\rho, z).\end{aligned}\tag{3-1.6}$$

We see from (3-1.6) that, when a point $P(\vec{x})$ in the physical space turns once around the vortex line near $z = -\infty$, the $\vec{\phi}$ and $\vec{\psi}$ rotate twice around the third axis in the isospin space.

There do not exist such continuous Higgs scalars $\vec{\phi}$ and $\vec{\psi}$ as to agree with (3-1.5) at $\theta = 0$ and, at $\theta = \pi$, rotate once around the third axis in the isospin space when the point $P(\vec{x})$ turns once around the vortex line near $z = -\infty$. For example, in (3-1.4), the many-valued Higgs scalars appear at the interval $0 < \theta < \pi$ if we replace φ by $\varphi/2$, though we get desired fields at $\theta = 0$ and π . We return to this problem later in this section.

Note that our ansatz (3-1.4) is connected with Mandelstam's homotopy¹³⁾ through the relations $\varphi_0 = \pi - \alpha$, $\varphi = 2\pi - \phi$ and $\theta = \pi - \beta$. The angle ϕ denotes Mandelstam's azimuthal angle and also the parameter β characterizes his homotopy.

Applying the singular gauge transformation $U(\theta, \varphi)$ to (3-1.4), we get the Higgs scalars (3-1.5) and then the Euler equations (3-1.2) are given by

$$D^\nu F'_{\mu\nu} = e^2 f_\phi^2 A'^{\perp\phi}_\mu + e^2 f_\psi^2 A'^{\perp\psi}_\mu, \quad (3-1.7)$$

where

$$A'^{\perp\phi}_\mu \equiv (0, A'^2_\mu, A'^3_\mu)$$

and

$$A'^{\perp\psi}_\mu \equiv (\sin^2 \varphi_0 A'^1_\mu - \cos \varphi_0 \sin \varphi_0 A'^2_\mu, -\cos \varphi_0 \sin \varphi_0 A'^1_\mu + \cos^2 \varphi_0 A'^2_\mu, A'^3_\mu).$$

The field tensor $F_{\mu\nu}$ acquires a new term $G_{\mu\nu}^*$ in the singular gauge:

$$A'_\mu = UA_\mu U^{-1} - \frac{i}{e} \partial_\mu U \cdot U^{-1}, \quad (3-1.8a)$$

$$F'_{\mu\nu} = \partial_\mu A'_\nu - \partial_\nu A'_\mu - ie[A'_\mu, A'_\nu] + G_{\mu\nu}^*, \quad (3-1.8b)^*)$$

$$G_{\mu\nu}^* = -\frac{i}{e} U(\partial_\mu \partial_\nu - \partial_\nu \partial_\mu)U^{-1}. \quad (3-1.8c)$$

The nonzero components of $G_{\mu\nu}^*$ are given by

$$\begin{aligned} G_{12}^*(x) &= -G_{21}^*(x) \\ &= \frac{2\pi}{e} \left\{ \frac{\tau^1}{2} \cdot \frac{x}{r} + \frac{\tau^2}{2} \cdot \frac{y}{r} + \frac{\tau^3}{2} \left(1 - \frac{z}{r} \right) \right\} \delta(x) \delta(y) \\ &= \frac{\tau^3}{2} \cdot \frac{4\pi}{e} \delta(x) \delta(y) \theta(-z), \quad \text{except for the origin,} \quad (3-1.9) \end{aligned}$$

where $r \equiv |\vec{x}|$, and (2.8) and the relation $J_{\mu\nu}(x) \equiv (\partial_\mu \partial_\nu - \partial_\nu \partial_\mu) \theta = 0$ (except for the origin) have been used^{**}). The corresponding dual tensor $G_{\mu\nu}$ can be expressed by Dirac's string variables:

$$G^{\mu\nu}(x) = \frac{\tau^3}{2} \cdot g \int_{-\infty}^{\infty} d\tau \int_{-\infty}^0 d\sigma [y^\mu, y^\nu] \delta^4(x-y) \quad (3-1.10)$$

*) This expression was also written by Tze and Ezawa¹¹⁾, but they did not refer to the explicit forms of singular gauge transformations in the semi-infinite and finite cases.

***) The $J_{\mu\nu}(x)$ may have singularity at the origin. It is easily checked that, in particular, the $J_{\mu\nu}(x)$ has no $\delta^3(x)$ singularity.

with the y^μ in §2 and with $g = -(4\pi/e)$ (two Dirac units). Consequently, the new term $G_{\mu\nu}^*$ in $F'_{\mu\nu}$ can be regarded as the one derived from the Dirac string with the strength of two Dirac units extending on the z -axis from $z = -\infty$ to the origin.

We now investigate the behavior of \vec{A}'_μ , $\vec{\phi}'$ and $\vec{\psi}'$ in the singular gauge near the negative z -axis, where the symmetry breaking is recovered. Because $G_{\mu\nu}^*(x)$ is proportional to $(\tau^3/2)\delta(x)\delta(y)\theta(-z)$, we can expect that A'_{φ^3} behaves like $1/\rho$ near the negative z -axis. This is justified below, if we can expand the gauge potentials $A'_\rho^a(\rho, z)$ and $A'_{\varphi^a}(\rho, z)$ in Laurent series around $\rho = 0$ (with the fixed z). We must extend the argument of Patkós¹⁵⁾ from his abelian to our nonabelian cases. We require the finiteness of the energy per unit length of the vortex line, which leads to the following conditions:

$$D'_\mu\phi', D'_\mu\psi', F'_{\mu\nu} = O(\rho^{-p}), \quad p < 1 \quad \text{for } \rho \rightarrow 0. \quad (3-1.11)$$

Then the third component of the "magnetic fluxes" is evaluated by integrating over an infinitesimal disk of radius ε around the z -axis:

$$\begin{aligned} \Phi^3 &= \int \vec{H}'^3 \cdot d\vec{f} \\ &= \oint A'_{\varphi^3} d\ell - e \int dx dy (-A'_{\varphi^1} A'^2_{\rho} + A'_{\rho^1} A'^2_{\varphi}) - \frac{4\pi}{e} \theta(-z) = O(\varepsilon^{2-p}), \end{aligned} \quad (3-1.12)$$

where $H'^{ai} \equiv -(1/2)\varepsilon_{ijk} F'^{ajk}$. Substitution of the Laurent series $A'_I^a(\rho, z) = \sum_{\ell=-\infty}^{\infty} \alpha_I^a(\ell, z) \rho^\ell$ ($I = \rho, \varphi$ indices) into (3-1.12) leads to

$$\alpha_{\varphi}^3(-1, \bar{z}) = \frac{2}{e} \theta(-\bar{z}),$$

$$\alpha_{\varphi}^3(-2, \bar{z}) = \alpha_{\varphi}^3(-3, \bar{z}) = \dots = 0, \quad (3-1.13)$$

and, in addition, some recursion relations among $\alpha_{\mathbb{I}}^a(l, z)$'s are obtained. As a result $A_{\varphi}^{\prime 3}$ behaves like $1/\rho$ near the negative z -axis:

$$A_{\varphi}^{\prime 3}(\rho, \bar{z}) = \frac{2}{e\rho} \theta(-\bar{z}) + O(\rho^0) \quad \text{for } \rho \rightarrow 0. \quad (3-1.14)$$

We similarly find that $A_{\varphi}^{\prime 1}$ and $A_{\varphi}^{\prime 2}$ have no terms with the inverse powers of ρ .

Subsequently we apply the conditions (3-1.11) to the Higgs scalars $\vec{\phi}'$ and $\vec{\psi}'$. Their covariant derivatives have, say, the following components:

$$(D^{\mu} \phi')_{\varphi}^2 = e A_{\varphi}^{\prime 3} f_{\phi},$$

$$(D^{\mu} \psi')_{\varphi}^1 = -e A_{\varphi}^{\prime 3} f_{\psi} \sin \varphi_0. \quad (3-1.15)$$

From (3-1.11), (3-1.14) and (3-1.15), we get the asymptotic forms of the form factors of the Higgs scalars near the negative z -axis:

$$f_{\phi}(\rho, \bar{z}) \sim C_{\phi}(\bar{z}) \rho^{\nu(\bar{z})}, \quad \nu(\bar{z}) > 0,$$

$$f_{\psi}(\rho, \bar{z}) \sim C_{\psi}(\bar{z}) \rho^{\nu'(\bar{z})}, \quad \nu'(\bar{z}) > 0 \quad \text{for } \bar{z} < 0, \rho \rightarrow 0. \quad (3-1.16)$$

The Higgs scalars $\vec{\phi}'$ and $\vec{\psi}'$ have zeros on the negative z-axis, which implies the continuity on the negative z-axis of the Higgs scalars (3-1.4) in the regular gauge. Furthermore we see the complementarity¹¹⁾ of the Dirac strings and the nodal lines of the Higgs scalars.

Next we investigate the behavior of \vec{A}'_{μ} , $\vec{\phi}'$ and $\vec{\psi}'$ at large distances from the vortex line. The Higgs scalars in this region have their vacuum expectation values: $|\vec{\phi}'| = F_{\phi}$ and $|\vec{\psi}'| = F_{\psi}$, where $F_{\phi} \equiv (-c_2/2c_4)^{1/2}$ and $F_{\psi} \equiv (-d_2/2d_4)^{1/2}$. Equation (3-1.7) implies that all the isospin components of $A'_{\mu}{}^a$ behave like the Yukawa-type^{*}) for large distances. By assuming the minimum of Higgs potential for the Higgs scalars

$$\vec{\phi}'(x) = (1, 0, 0)F_{\phi},$$

$$\vec{\psi}'(x) = (\cos\varphi_0, \sin\varphi_0, 0)F_{\psi}, \quad (3-1.17)$$

the Euler equations (3-1.7) is written by

$$D'^{\nu}F'_{\mu\nu} = e^2 F_{\phi}^2 A'_{\mu}{}^{\perp\phi} + e^2 F_{\psi}^2 A'_{\mu}{}^{\perp\psi}. \quad (3-1.18)$$

*) The eigenvalues of the mass matrix for $A'_{\mu}{}^1$ and $A'_{\mu}{}^2$ satisfy the equation $(m^2)^2 - e^2(\vec{\phi}'^2 + \vec{\psi}'^2)m^2 + e^4(\vec{\phi}' \times \vec{\psi}')^2 = 0$. This equation of m^2 has one real positive root if $|\vec{\phi}'| = |\vec{\psi}'|$ and $\vec{\phi}' \perp \vec{\psi}'$, and otherwise has two real positive roots.

Gauge potentials $A'_\mu{}^1$ and $A'_\mu{}^2$ can be set equal to zero because they have no string sources and (3-1.18) is reduced to^{*}

$$\partial^\nu (\partial_\mu A'_\nu{}^3 - \partial_\nu A'_\mu{}^3 + G_{\mu\nu}^{*3}) = m_V^2 A'_\mu{}^3, \quad (3-1.19)$$

where $m_V^2 = e^2 (F_\phi^2 + F_\psi^2)$. The equation (3-1.19) has the same form as in the Nambu model, and we have the following solution

$$A'_0{}^3(x) = 0$$

$$\vec{A}'^3(x) = \frac{1}{e} \int_{-\infty}^0 d\vec{s}' \cdot \vec{\nabla} \left\{ - \frac{e^{-m_V |\vec{x} - \vec{x}'|}}{|\vec{x} - \vec{x}'|} \right\}. \quad (3-1.20)$$

This is also approximate solution of (3-1.7) in the region far away from the vortex line.

So far we have investigated the behavior of the fields in the singular gauge. We now translate it into the regular gauge. To this aim, we perform the inverse transformation $U^{-1}(\theta, \varphi)$ to the fields $A'_\mu{}^a$, ϕ'^a and ψ'^a . For the Higgs scalars $\vec{\phi}$ and $\vec{\psi}$ we obtain (3-1.4). For the gauge potential $A'_\mu{}^a$ we have $A_0^a(x) = 0$ and

$$\frac{\tau^a}{2} A_i^a(x) = U^{-1}(\theta, \varphi) \frac{\tau^a}{2} A_i^a(x) U(\theta, \varphi) - \frac{i}{e} \partial_i U^{-1}(\theta, \varphi) \cdot U(\theta, \varphi). \quad (3-1.21)$$

^{*}) The equation (3-1.19) corresponds to Eq.(8) of Ref. 7) in a singular gauge where field $\vec{\chi}$ is real. Our (3-1.19), however, takes account of Dirac's term $G_{\mu\nu}^{*3}$ explicitly, in contrast to Ref. 7).

We easily see from (3-1.21) that the $1/\rho$ behavior of A_φ^3 is just cancelled by the pure gauge term, i.e., $-(i/e)\partial_i U^{-1} \cdot U$. The gauge potential A_φ^a in the regular gauge has no $1/\rho$ term near the z-axis.

At large distances ($r, \rho \gg m_V^{-1}$) far from the vortex line, the first term of the right-hand side of (3-1.21) rapidly decreases, so that A^μ approaches the expression

$$A^\mu(x) = -\frac{i}{e} \partial^\mu U^{-1}(\theta, \varphi) \cdot U(\theta, \varphi), \quad (3-1.22)$$

that is,

$$A_0^a(x) = 0 \quad \text{and} \quad A^{ai}(x) = \frac{1}{e} \left\{ \varepsilon_{iaj} x^j \frac{1}{r^2} - \frac{x^a}{r} \varepsilon_{izj} x^j \frac{1}{r(r+z)} \right\}. \quad (3-1.23)$$

If (3-1.23) is also used near the symmetry axis of vortex line, we see that only the component A_φ^3 has the singular line on the negative z-axis, which is in fact cancelled with the first term of the right-hand side of (3-1.21). Moreover all the other components A_ρ^a, A_z^a ($a = 1, 2, 3$) and A_φ^a ($a = 1, 2$) do not have singular line, but singular points at the origin.

At the infinite point $P(\rho, \varphi, z)$ where $z \rightarrow -\infty$ and ρ is large ($\rho \gg m_V^{-1}$), only the component A_φ^3 survives and then we get $A_\varphi^3 = 2/e\rho$. We thus see that, through the singular gauge transformation $U^{-1}(\theta, \varphi)$, the singular part of the gauge potential $A_\varphi^3 = 2/e\rho$ near the negative z-axis has been transferred into the tail of the gauge potential $A_\varphi^3 = 2/e\rho$ of the regular gauge at large distances where $z \rightarrow -\infty$.

The tail of the gauge potential $A_\varphi^3 = 2/e\rho$ yields the

"magnetic flux" of $4\pi/e$ (two Dirac units). On the other hand, in the case of infinitely-long vortex line, the smallest flux is $2\pi/e$ (one Dirac unit) (see (2.7) or (2.17)). According to Tze and Ezawa's¹¹⁾ argument, only the topologically unstable vortex lines whose fluxes are (in the SU(2) case) integral multiples of $4\pi/e$ admit the singularity-free end points. Our result is consistent with this argument. Our semi-infinite monopole-vortex system has no Dirac string in the regular gauge. Note that the flux $4\pi/e$ around the vortex line in the regular gauge is equal to the strength of the magnetic monopole at the origin in the singular gauge (see (3-1.9)). Further study on this point will be given in §5.

§3-2. A finite monopole-vortex system

We proceed in the same way as in §3-1 by replacing the singular gauge transformation $U(\theta, \varphi)$ with $U(\delta, \varphi)$.¹⁰⁾ The angle δ is the one from which the monopole $\vec{a}_+ = (0, 0, a)$ and the anti-monopole $\vec{a}_- = (0, 0, -a)$ are seen: $\delta = \tan^{-1}\{2a\rho/(r^2 - a^2)\}$ (Fig.4). The $U(\theta, \varphi)$ is a special case of $U(\delta, \varphi)$, that is, if the monopole is placed at the origin and the antimonopole at the point $(0, 0, -2a)$, the angle δ approaches θ by the limit $a \rightarrow \infty$ (Fig.5). Therefore almost the same results as in §3-1 are obtained also in this finite case.

We shall consider an axially symmetric static finite monopole-vortex system whose energy is localized about the interval $-a < z < a$ on the z -axis, which we denote with I in this section. Our ansatz for the Higgs scalars is given by (3-1.4) where θ is replaced by δ in the regular gauge and (3-1.5) in the singular gauge, and these are connected with each other through the $U(\delta, \varphi)$.

Near the z -axis with $|z| > a$, the Higgs scalars have constant directions in the isospin space, i.e., they are given by (3-1.5). Near the interval I , the Higgs scalars are equal to the right-hand side of (3-1.6). Similarly to the Higgs scalars of §3-1, they rotate twice around the third axis in the isospin space when the point $P(\vec{x})$ turns once around the vortex line.

After the singular gauge transformation $U(\delta, \varphi)$, we get the Higgs scalars (3-1.5) and the Euler equations (3-1.2) are given by (3-1.7) and (3-1.8a)~(3-1.8c). In this case the nonzero components of $G_{\mu\nu}^*$ are

$$\begin{aligned}
 G_{12}^*(x) &= -G_{21}^*(x) \\
 &= \frac{2\pi}{e} \left\{ \frac{\tau^1}{2} \cdot \frac{2ax}{r_+ r_-} + \frac{\tau^2}{2} \cdot \frac{2ay}{r_+ r_-} + \frac{\tau^3}{2} \cdot \left(1 - \frac{r^2 - a^2}{r_+ r_-} \right) \right\} \delta(x) \delta(y) \\
 &= \frac{\tau^3}{2} \cdot \frac{4\pi}{e} \delta(x) \delta(y) \{ \theta(a-z) - \theta(-a-z) \}
 \end{aligned}$$

except for the points \vec{a}_\pm , (3-2.1)

where $r_\pm \equiv |\vec{x} - \vec{a}_\pm|$, and (2.8) and the relation $L_{\mu\nu}(x) \equiv (\partial_\mu \partial_\nu - \partial_\nu \partial_\mu) \delta = 0$ (except for the points \vec{a}_\pm) are used.*) The corresponding dual tensor $G_{\mu\nu}$ can be expressed by Dirac's string variables as (3-1.10), where the Dirac string extends on the z-axis from $z = -a$ to $z = a$.

The behavior of \vec{A}'_μ , $\vec{\phi}'$ and $\vec{\psi}'$ near the z-axis is obtained from arguments similar to those given in §3-1. The gauge potentials A'^a near the z-axis are

$$A'_\varphi^1(\rho, z), A'_\varphi^2(\rho, z) = O(\rho^0) \tag{3-2.2a}$$

$$A'_\varphi^3(\rho, z) = \frac{2}{e\rho} \{ \theta(a-z) - \theta(-a-z) \} + O(\rho^0) \quad \text{for } \rho \rightarrow 0. \tag{3-2.2b}$$

*) The $L_{\mu\nu}(x)$ may have singularities at the points \vec{a}_\pm . It is easily checked that, in particular, the $L_{\mu\nu}(x)$ has no $\delta(x) \delta(y) \delta(z \pm a)$ singularities.

We also see that the Higgs scalars have zeros at the interval I, which implies the continuity at the interval I of the Higgs scalars in the regular gauge. Furthermore we see the complementarity¹¹⁾ of the Dirac strings and the nodal lines of the Higgs scalars.

Under the London approximation, we get the Euler equation (3-1.19) with $G_{\mu\nu}^*$ of (3-2.1) and the gauge potential $A_\mu^{\prime 3}$ is solved as $A_0^{\prime 3}(x) = 0$ and

$$\vec{A}^{\prime 3}(x) = (1/e) \int_{-a}^a d\vec{s}' \times \vec{\nabla} \left\{ \frac{-\exp(-m_V |\vec{x} - \vec{x}'|)}{|\vec{x} - \vec{x}'|} \right\}. \quad (3-2.3)$$

Finally we return to the original regular gauge by means of $U^{-1}(\delta, \varphi)$. As in §3-1, we see that the $1/\rho$ behavior of $A_\varphi^{\prime 3}$ near the interval I is removed in the regular gauge. At large distances from the vortex line, we get the following boundary expressions for A_μ :

$$A^\mu(x) = -\frac{i}{e} \partial^\mu U^{-1}(\delta, \varphi) \cdot U(\delta, \varphi) \quad \text{for } R \gg m_V^{-1}, \quad (3-2.4)$$

where R stands for r_+ , ρ and r_- , according as the reference point is in the regions $z > a$, $a > z > -a$ or $z < -a$. From (3-2.4), the ρ -, φ - and z -components of A_i^a are written as follows:

$$\vec{e}_\rho A_\rho^a + \vec{e}_z A_z^a = \frac{1}{e} \epsilon_{a3j} \frac{x^j}{\rho} \vec{\nabla} \delta, \quad (a=1, 2, 3)$$

$$A_\varphi^a = -\frac{1}{e} \cdot \frac{2ax^a}{r+r-\rho}, \quad (a=1, 2)$$

$$A_\varphi^3 = \frac{1}{e} \cdot \frac{r+r-r^2-a^2}{r+r-\rho}, \quad (3-2.5a)$$

where

$$\vec{\nabla} \delta = -\frac{2a}{(r+r)^2} (\rho^2 - z^2 + a^2) \vec{e}_\rho - \frac{4a\rho z}{(r+r)^2} \vec{e}_z. \quad (3-2.5b)$$

If (3-2.5a) is also used near the symmetry axis of vortex line, we see that only the component A_φ^3 has the singular line at the interval I to be cancelled in fact. Moreover all the other components do not have singular line, but singular points at \vec{a}_\pm . For the long vortex line where $a \rightarrow \infty$, only the component A_φ^3 survives at large distances and we get $A_\varphi^3 = 2/e\rho$. It leads to flux $4\pi/e$ (two Dirac units). Our finite monopole-vortex system has no Dirac string in the regular gauge. Our finite system is dynamically unstable if the Higgs scalars $\vec{\phi}$ and $\vec{\psi}$ are treated as dynamical fields, because the monopole and antimonopole of the system can annihilate with each other into the vacuum state.

§4. The monopole-vortex systems in an SU(3) Higgs model

§4-1. Finite and semi-infinite monopole-vortex systems

We now extend the argument of §3 from the SU(2) gauge group to the SU(3) one. Our SU(3) Higgs model contains the three Higgs scalars $\Phi^{(i)}$ ($i = 1, 2, 3$) each transforming as the octet of SU(3). By 3×3 -matrix notation our Lagrangian is given by

$$\mathcal{L} = -\frac{1}{2} \text{Tr} F_{\mu\nu}^2 + \sum_{i=1}^3 \text{Tr} D_{\mu} \Phi^{(i)} D^{\mu} \Phi^{(i)} - V(\Phi), \quad (4-1.1)$$

where

$$\begin{aligned} F_{\mu\nu} &= \partial_{\mu} A_{\nu} - \partial_{\nu} A_{\mu} - ie[A_{\mu}, A_{\nu}], \\ D_{\mu} \Phi^{(i)} &= \partial_{\mu} \Phi^{(i)} - ie[A_{\mu}, \Phi^{(i)}], \\ A_{\mu} &= \frac{\lambda^{\alpha}}{2} A_{\mu}^{\alpha}, \quad \Phi^{(i)} = \frac{\lambda^{\alpha}}{2} \Phi^{(i)\alpha} \end{aligned}$$

with the Gell-Mann matrices λ^{α} . We take the Higgs potential $V(\Phi)$ in (4-1.1) as

$$\begin{aligned} V(\Phi) &= c_1 \sum_{i=1}^3 \left(\text{Tr} \Phi^{(i)2} - \frac{1}{2} F^2 \right)^2 + c_2 \sum_{\text{cyclic}} \text{Tr} \left(\{ \Phi^{(i)}, \Phi^{(j)} \} - \frac{1}{2} F \Phi^{(k)} \right)^2, \\ &\quad (c_1, c_2, F > 0) \end{aligned} \quad (4-1.2)$$

where $\{ \Phi^{(i)}, \Phi^{(j)} \} = \Phi^{(i)} \Phi^{(j)} + \Phi^{(j)} \Phi^{(i)}$ and \sum_{cyclic} denotes cyclic summation over the set of indices $(i, j, k) = (1, 2, 3), (2, 3, 1),$ and $(3, 1, 2)$. The Euler equations are

$$D^{\nu} F_{\mu\nu} = -ie \sum_{i=1}^3 [\Phi^{(i)}, D_{\mu} \Phi^{(i)}], \quad (4-1.3)$$

$$D^{\mu} D_{\mu} \Phi^{(i)} = -\partial V / \partial \Phi^{(i)}, \quad i=1, 2, 3. \quad (4-1.4)$$

We have chosen the Higgs potential $V(\Phi)$ so as to be one of the permutation-invariant forms of the three Higgs scalars $\Phi^{(i)}$. Thus our Lagrangian (4-1.1) has an additional discrete symmetry as well as local $SU(3)$ symmetry. We assume this symmetry only from aesthetic reasons.

We consider a static axially symmetric finite monopole-vortex system whose energy is localized about the interval $x=y=0, -a \leq z \leq a$. We impose the boundary conditions at $r=\infty$

$$\Phi^{(1)} = F U^{-1} \frac{\lambda^1}{2} U, \quad \Phi^{(2)} = F U^{-1} \frac{\lambda^4}{2} U, \quad \Phi^{(3)} = F U^{-1} \frac{\lambda^6}{2} U, \quad (4-1.5)$$

and $D_\mu \Phi^{(i)} = 0$. We see that (4-1.5) is an absolute minimum state of the Higgs potential $V(\Phi) (\geq 0)$ since this state yields $V(\Phi) = 0$. Furthermore, in the unitary gauge, eight unphysical massless Goldstone bosons are absorbed into the longitudinal components of the gauge potentials A_μ^α and consequently there remain only massive particles: eight massive vector fields and sixteen massive scalars. More details will be presented in Appendix B. Singular $SU(3)$ matrix $U = U(\delta, \varphi)$ is given by

$$U(\delta, \varphi) = \begin{pmatrix} e^{-i\alpha\varphi} & & 0 \\ & e^{-i\beta\varphi} & \\ 0 & & e^{i\gamma\varphi} \end{pmatrix} \begin{pmatrix} c & s & 0 \\ -s c & c^2 & s \\ s^2 & -c s & c \end{pmatrix} \begin{pmatrix} e^{i\alpha\varphi} & & 0 \\ & e^{i\beta\varphi} & \\ 0 & & e^{i\gamma\varphi} \end{pmatrix}, \quad (4-1.6)$$

where $c \equiv \cos(\delta/2)$, $s \equiv \sin(\delta/2)$, and α, β and γ are constant parameters. We impose an additional condition $\alpha + \beta + \gamma = 0$ without loss of generality. The matrix (4-1.6) gives the finite

monopole-vortex system with a monopole at \vec{a}_+ and an antimonopole at \vec{a}_- (Fig.6). For the semi-infinite system, the angle δ is only replaced by the zenith angle $\theta = \tan^{-1}(\rho/z)$.

The singular tensor $G_{\mu\nu}^*$ of this case has the components

$$G_{12}^*(x) = -G_{21}^*(x) \tag{4-1.7}$$

$$= \left\{ \frac{2\pi}{e}(-3\beta) \frac{\lambda^3}{2} + \frac{2\sqrt{3}\pi}{e}(\alpha-\gamma) \frac{\lambda^8}{2} \right\} \delta(x) \delta(y) \{ \theta(a-z) - \theta(-a-z) \},$$

except for the points \vec{a}_{\pm} .

When we impose the following ansatz for the Higgs scalars of $r \neq \infty$

$$\Phi^{(1)}(x) = f^{(1)}(\rho, z) U^{-1}(x) \frac{\lambda^1}{2} U(x),$$

$$\Phi^{(2)}(x) = f^{(2)}(\rho, z) U^{-1}(x) \frac{\lambda^4}{2} U(x), \tag{4-1.8}$$

$$\Phi^{(3)}(x) = f^{(3)}(\rho, z) U^{-1}(x) \frac{\lambda^6}{2} U(x),$$

these fields, after the transformation U , become

$$\Phi^{(i)}(x) = F \frac{\lambda^i}{2}, \quad \Phi^{(2)}(x) = F \frac{\lambda^4}{2}, \quad \Phi^{(3)}(x) = F \frac{\lambda^6}{2}, \tag{4-1.9}$$

in the constant $f^{(i)}$ approximation corresponding to the London approximation. All the octet components of $A_{\mu}^{\prime\alpha}$ have constant nonzero masses and behave like the Yukawa-type for large distances. The Euler equations for $A_{\mu}^{\prime 3}$ and $A_{\mu}^{\prime 8}$ are, in the temporal gauge $A_0^{\prime 3} = A_0^{\prime 8} = 0$, given by

$$(\square + m_V^2) \vec{A}'^3 = \frac{2\pi}{e} (-3\beta) (\vec{\nabla} \times \vec{e}_z) \delta(x) \delta(y) \{ \theta(a-z) - \theta(-a-z) \},$$

$$(\square + m_V^2) \vec{A}'^8 = \frac{2\sqrt{3}\pi}{e} (\alpha - \gamma) (\vec{\nabla} \times \vec{e}_z) \delta(x) \delta(y) \{ \theta(a-z) - \theta(-a-z) \},$$

(4-1.10)

where $m_V^2 = (3/2)e^2 F^2$ ^{*}. All the other components of potentials can be set equal to zero, because they have no string sources, such as (4-1.7). The equations (4-1.10) are solved as follows.

$$\vec{A}'^3(x) = \frac{3\beta}{2e} (\vec{\nabla} \times \vec{e}_z) \int_{-a}^a dz' \frac{e^{-m_V |\vec{x} - \vec{x}'|}}{|\vec{x} - \vec{x}'|},$$

(4-1.11)

$$\vec{A}'^8(x) = \frac{\sqrt{3}}{2e} (\gamma - \alpha) (\vec{\nabla} \times \vec{e}_z) \int_{-a}^a dz' \frac{e^{-m_V |\vec{x} - \vec{x}'|}}{|\vec{x} - \vec{x}'|},$$

where $\vec{x}' = (0, 0, z')$. Note that the $A_\varphi'^3$ and $A_\varphi'^8$ of (4-1.11) have singular line at the interval $x = y = 0, -a \leq z \leq a$. When we gauge-transform A_μ' into the original A_μ by the U^{-1} , we see that this line singularity is cancelled by the pure gauge term

*) Any two of the three Higgs scalars (4-1.5) are sufficient to make all the octet components of A_μ^α massive. However they give unequal masses for A_μ^3 and A_μ^8 , while the three Higgs scalars (4-1.5) give an equal mass. This is one of the reasons for our choice of the three Higgs scalars (4-1.5).

$-(i/e)\partial_\mu U^{-1}\cdot U$. The gauge potential A_φ in the regular gauge have no Dirac string singularity.

The monopoles at the point \vec{a}_+ of vortices of A'^3 - and A'^8 -potentials have strengths

$$g_3 \equiv \frac{2\pi}{e} \times 3\beta, \quad g_8 \equiv \frac{2\sqrt{3}\pi}{e} (\gamma - \alpha), \quad (4-1.12)$$

for A'^3 and A'^8 respectively. The quantization conditions of A'^3 and A'^8 magnetic charges are obtained from the conditions

$$3\alpha, 3\beta, 3\gamma, \alpha - \beta, \beta - \gamma, \gamma - \alpha = \text{integers}, \quad (4-1.13)$$

which are derived from the single-valuedness of the Higgs scalars $\Phi^{(i)}$. Some of the nontrivial values of α , β and γ which fulfill (4-1.13) and the condition $\alpha + \beta + \gamma = 0$ are listed in Tables 1(a) and (b).

There is a difficulty that $A'_\mu{}^3$ and $A'_\mu{}^8$ vortices are mixed by gauge transformation, that is, they are not gauge invariant. In order to overcome this we define three gauge-invariant field strengths

$$a_{\mu\nu} = \text{Tr} \hat{\Phi}^{(1)2} F_{\mu\nu}, \quad b_{\mu\nu} = \text{Tr} \hat{\Phi}^{(2)2} F_{\mu\nu}, \quad c_{\mu\nu} = \text{Tr} \hat{\Phi}^{(3)2} F_{\mu\nu}. \quad (4-1.14)$$

These are not independent, because the sum of them vanishes:

$$a + b + c = 0. \quad (4-1.15)$$

The $\hat{\Phi}^{(i)}$ are normalized Higgs scalars as follows $\text{Tr} \hat{\Phi}^{(i)2} = 1/2$. From these three dependent fields, we define two independent field strengths $\mathcal{F}_{\mu\nu}^{\text{I}}$ and $\mathcal{F}_{\mu\nu}^{\text{II}}$ as follows¹³⁾

$$\mathcal{F}_{\mu\nu}^{\text{I}} = 2(b-c)_{\mu\nu}, \quad \mathcal{F}_{\mu\nu}^{\text{II}} = \frac{2}{\sqrt{3}}(2a-b-c)_{\mu\nu}, \quad (4-1.16a)$$

for the case (a) of Table 1 and

$$\mathcal{F}_{\mu\nu}^{\text{I}} = \frac{2}{\sqrt{3}}(2a-b-c)_{\mu\nu}, \quad \mathcal{F}_{\mu\nu}^{\text{II}} = 2(b-c)_{\mu\nu}, \quad (4-1.16b)$$

for the case (b) of Table 1, respectively. Through these field strengths $\mathcal{F}_{\mu\nu}^{\text{I}}$ and $\mathcal{F}_{\mu\nu}^{\text{II}}$, we can define two gauge-invariant magnetic fluxes Φ_{I} and Φ_{II} of the monopole at the point \vec{a}_+

$$\Phi_{\text{I}} = \int \vec{H}_{\text{I}} \cdot d\vec{S}, \quad \Phi_{\text{II}} = \int \vec{H}_{\text{II}} \cdot d\vec{S}, \quad (4-1.17)$$

where $\vec{H}_{\text{I(II)}} = (\mathcal{F}_{01}^*, \mathcal{F}_{02}^*, \mathcal{F}_{03}^*)^{\text{I(II)}}$ and S is the closed surface enclosing the point \vec{a}_+ . In our "vortex gauge", the $\Phi_{\text{I(II)}}$ and $\Phi_{\text{II(I)}}$ fluxes (4-1.17) coincides with the coefficients of $\lambda^3/2$ and $\lambda^8/2$ of (4-1.7) for the case (a) ((b)) of Table 1. The Φ_{I} and Φ_{II} are related to the parameters α , β and γ as follows

$$\Phi_{\text{I}} = -\frac{2\pi}{e} \times 3\beta, \quad \Phi_{\text{II}} = \frac{2\sqrt{3}\pi}{e} (\alpha - \gamma), \quad (4-1.18a)$$

for the case (a) and

$$\Phi_I = \frac{2\sqrt{3}\pi}{e}(\alpha-\gamma) \quad , \quad \Phi_{II} = -\frac{2\pi}{e} \times 3\beta \quad , \quad (4-1.18b)$$

for the case (b) of Table 1, respectively. More detail will be given in §5. We see from Tables 1 (a) and (b) that the smallest fluxes are

$$\Phi_I = \pm \frac{6\pi}{e} \quad , \quad \Phi_{II} = \pm \frac{2\sqrt{3}\pi}{e} \quad , \quad (4-1.19a)$$

for the case (a) and

$$\Phi_I = \pm \frac{2\sqrt{3}\pi}{e} \quad , \quad \Phi_{II} = \pm \frac{2\pi}{e} \quad , \quad (4-1.19b)$$

for the case (b) of Table 1, respectively.

The I and II magnetic vortex fluxes (4-1.17) with the values of α , β and γ of Tables 1 (a) and (b) defines the two magnetic charges $g_I = -\Phi_I$ and $g_{II} = -\Phi_{II}$ for red, blue and green quarks respectively, provided quarks are identified with monopoles attached to the ends of vortices (Fig.6). Red quark is defined by the one from which both vortices I and II originate. Blue and green quarks are defined similarly (see Tables 1 (a) and (b)). By this definition we can define 'color' chemical bonds between red, blue and green quarks. Thus we succeed in the construction of 'color' chemical bond model.⁵⁾ It is accidental that the 'color' of monopoles of Table 1 coincides with λ^3 and λ^8 of SU(3) group. The origin of this 'color' originates from the topology of the

fields. In what follows, we shall denote this 'color' by adding quotation marks in order to discriminate this from the conventional color.

§4-2. Y-shaped and Δ -shaped baryons

It is very interesting that our dynamical model enables us to construct Y-shaped (or Δ -shaped) baryon. We impose the boundary condition at $r=\infty$ analogous to finite monopole-vortex system:

$$\Phi^{(1)} = F S^{-1} \lambda^1 S, \quad \Phi^{(2)} = F S^{-1} \lambda^4 S, \quad \Phi^{(3)} = F S^{-1} \lambda^6 S. \quad (4-2.1)$$

Matrix S is defined by the unitary matrices U_1, U_2, U_3, Γ_1 and Γ_2 .

$$S = U_1 \Gamma_1 U_2 \Gamma_2 U_3. \quad (4-2.2)$$

$U_1, U_2,$ and U_3 are similar matrices as (4-1.6), which give the finite Dirac strings with orientations $\theta = 0, \mu, -\nu$ and lengths $2a, 2b,$ and $2c$ respectively (Fig.7). Γ_1 and Γ_2 are inserted so as to preserve the λ^3 and λ^8 forms of vortex line. Otherwise λ^3 and λ^8 would be changed into $A\lambda^3 A^{-1}$, and $A\lambda^8 A^{-1}$ with some $SU(3)$ matrix A . It will be also shown that Γ_1 and Γ_2 can be so chosen as to have no φ dependence, and thus give no Dirac string. Matrices U_i 's are characterized by angles $\delta^{(i)}$ and $\varphi^{(i)}$ as follows.

$$U_i = U(\delta^{(i)}, \varphi^{(i)}), \quad (4-2.3)$$

where

$$\delta^{(1)} = \tan^{-1} [2ap / \{x^2 + y^2 + (z-a)^2 - a^2\}], \quad \varphi^{(1)} = \tan^{-1}(y/x),$$

$$\delta^{(2)} = \tan^{-1} [2b \{ (x \cos \mu - z \sin \mu)^2 + y^2 \}^{1/2} / \{ (x \cos \mu - z \sin \mu)^2 + y^2 + (x \sin \mu + z \cos \mu - b)^2 - b^2 \}],$$

$$\varphi^{(2)} = \tan^{-1} \{ y / (x \cos \mu - z \sin \mu) \},$$

$$\delta^{(3)} = \tan^{-1} [2c \{ (x \cos \nu + z \sin \nu)^2 + y^2 \}^{1/2} / \{ (x \cos \nu + z \sin \nu)^2 + y^2 + (-x \sin \nu + z \cos \nu - c)^2 - c^2 \}],$$

$$\varphi^{(3)} = \tan^{-1} \{ y / (x \cos \nu + z \sin \nu) \}.$$

(4-2.4)

The angles $\delta^{(i)}$ and $\varphi^{(i)}$ are the vertex angle δ of the triangle formed by the observed point and the two end points of the (i) vortex line and the azimuthal angle around this (i) vortex line, respectively (Fig.7). From (4-2.2), (4-2.3) and (4-2.4), Dirac string is easily calculated as follows^{*})

$$\begin{aligned} ie G_{\mu\nu}^* &= S(\partial_\mu \partial_\nu - \partial_\nu \partial_\mu) S^{-1} \\ &= U_1 [\partial_\mu, \partial_\nu] U_1^{-1} + U_1 T_1 \{ U_2 [\partial_\mu, \partial_\nu] U_2^{-1} \} T_1^{-1} U_1^{-1} \\ &\quad + U_1 T_1 U_2 T_2 \{ U_3 [\partial_\mu, \partial_\nu] U_3^{-1} \} T_2^{-1} U_2^{-1} T_1^{-1} U_1^{-1}. \end{aligned} \quad (4-2.5)$$

*) It is to be remarked that the operation $[\partial_\mu, \partial_\nu]$ obeys the conventional rule of differentiation, namely $[\partial_\mu, \partial_\nu](AB) = [\partial_\mu, \partial_\nu]A \cdot B + A[\partial_\mu, \partial_\nu]B.$

Γ_1 is chosen so as to make $U_1 \Gamma_1 = \mathbb{1}$ on the axis (2), and Γ_2 is also chosen so as to make $U_1 \Gamma_1 U_2 \Gamma_2 = \mathbb{1}$ on the axis (3). We here choose them

$$T_1 = U^{-1}(\delta^{(1)}, \varphi^{(1)} = 0), \quad T_2 = U^{-1}(\delta^{(2)}, \varphi^{(2)} = 0). \quad (4-2.6)$$

These Γ_1 and Γ_2 have no $\varphi^{(i)}$ dependence, and thus give no Dirac string. The nonzero components of $G_{\mu\nu}^*$ are given by

$$\begin{aligned} G_{12}^*(x) &= -G_{21}^*(x) \\ &= M_1 \delta(x) \delta(y) \{ \theta(2a-z) - \theta(-z) \} \\ &\quad + M_2 \cos \mu \cdot \delta(x') \delta(y) \{ \theta(2b-z') - \theta(-z') \} \\ &\quad + M_3 \cos \nu \cdot \delta(x'') \delta(y) \{ \theta(2c-z'') - \theta(-z'') \}, \\ G_{23}^*(x) &= -G_{32}^*(x) \\ &= M_1 \sin \mu \cdot \delta(x') \delta(y) \{ \theta(2b-z') - \theta(-z') \} \\ &\quad - M_2 \sin \nu \cdot \delta(x'') \delta(y) \{ \theta(2c-z') - \theta(-z'') \}, \end{aligned} \quad (4-2.7)$$

where

$$M_i \equiv \left\{ \frac{2\pi}{e} (-3\beta_i) \frac{\lambda^3}{2} + \frac{2\sqrt{3}\pi}{e} (\alpha_i - \gamma_i) \frac{\lambda^8}{2} \right\}, \quad i=1, 2, 3,$$

$$x' = x \cos \mu - z \sin \mu, \quad z' = x \sin \mu + z \cos \mu,$$

$$x'' = x \cos \nu + z \sin \nu, \quad z'' = -x \sin \nu + z \cos \nu, \quad (4-2.8)$$

and α_i , β_i and γ_i are constant parameters which characterize the matrix U_i .

In Fig.7, at the junction of three vortices, the each sum of A^3 and A^8 magnetic fluxes is assumed to be zero. In order to fulfill this requirement, the parameters α_i , β_i and γ_i of (4-2.8) are restricted to certain values. We now derive these constraints by calculating the $\partial^i G_{i0}$ from which the positions and the strengths of monopoles are immediately seen. From (4-2.7) we obtain^{*})

$$\begin{aligned} \partial^i G_{i0}(x) = & M_1 \delta(x) \delta(y) \delta(z-2a) + M_2 \delta(x') \delta(y) \delta(z'-2b) \\ & + M_3 \delta(x'') \delta(y) \delta(z''-2c) - g_{\text{junc.}} \delta^3(x), \end{aligned} \quad (4-2.9)$$

where

$$\begin{aligned} g_{\text{junc.}} & \equiv \sum_{i=1}^3 M_i \\ & = \sum_{i=1}^3 \left\{ \frac{2\pi}{e} (-3\beta_i) \frac{\lambda^3}{2} + \frac{2\sqrt{3}\pi}{e} (\alpha_i - \gamma_i) \frac{\lambda^8}{2} \right\}. \end{aligned} \quad (4-2.10)$$

Note that the total magnetic flux (or charge) Φ_{tot} of this Y-shaped

^{*}) We here assume $(\partial_\mu \partial_\nu - \partial_\nu \partial_\mu) \delta^{(i)} = 0$, for simplicity.

system is automatically zero because of its construction, that is

$$\begin{aligned}\Phi_{tot} &= \sum_{i=1}^3 M_i - g_{junc}. \\ &\equiv 0.\end{aligned}\tag{4-2.11}$$

We also see that there is no magnetic monopole at the junction of three vortices if the following conditions are satisfied.

$$\sum_{i=1}^3 \alpha_i = 0, \quad \sum_{i=1}^3 \beta_i = 0, \quad \sum_{i=1}^3 \gamma_i = 0,\tag{4-2.12}$$

where we have used the relations

$$\alpha_i + \beta_i + \gamma_i = 0, \quad i=1, 2, 3.\tag{4-2.13}$$

We see that the parameters α , β and γ of Tables 1 (a) and (b) satisfy the conditions (4-2.12), provided we choose them as

$$\begin{aligned}(\alpha_1, \beta_1, \gamma_1) &= (-1, 1, 0), \\ (\alpha_2, \beta_2, \gamma_2) &= (0, -1, 1), \\ (\alpha_3, \beta_3, \gamma_3) &= (1, 0, -1),\end{aligned}\tag{4-2.14}$$

for the case (a) and as

$$\begin{aligned}(\alpha_1, \beta_1, \gamma_1) &= (\frac{1}{3}, \frac{1}{3}, -\frac{2}{3}), \\ (\alpha_2, \beta_2, \gamma_2) &= (-\frac{2}{3}, \frac{1}{3}, \frac{1}{3}), \\ (\alpha_3, \beta_3, \gamma_3) &= (\frac{1}{3}, -\frac{2}{3}, \frac{1}{3}),\end{aligned}\tag{4-2.15}$$

for the case (b), respectively. Thus the Y-shaped baryon may be imagined to be constructed from the three meson systems $R\bar{R}$, $B\bar{B}$ and $G\bar{G}$ of §4-1 by gathering their three antimonopoles \bar{R} , \bar{B} and \bar{G} at the junction of this baryon system, where the each sum of two magnetic charges of \bar{R} , \bar{B} and \bar{G} must vanish.

For the Δ -shaped baryon shown in Fig.8, singular $SU(3)$ matrix S is given by (4-2.2) where U_i 's are the matrices which give the finite Dirac strings with orientations $\theta = 0, \mu, \nu$ and lengths $2a, 2b$ and $2c$ respectively. Matrices U_i 's are characterized by $\delta^{(i)}$ and $\varphi^{(i)}$: the vertex angle of the triangle formed by the observed point and the two end points of the (i) vortex line and the azimuthal angle around this (i) vortex line, respectively. Γ_1 and Γ_2 can be chosen, analogously to the Y-shaped baryon, so as to preserve the λ^3 and λ^8 forms of vortex lines.

Note that in this Δ -shaped baryon none of the three vortices can have the unit fluxes of Tab.1(a) or (b) but they have at least two times of the unit fluxes. For example the monopoles at the three vertices of the Δ -shaped baryon of Fig.8, which we denote R' , B' and G' , have twice color fluxes of R , B and G . It may be concluded that Y-shaped baryon having junction is more preferable than Δ -shaped baryon with no junction. It is shown that our monopole-vortex model enables us to discuss hadrons of any shape by introducing appropriate matrix U and the junction.¹⁹⁾

It is quite an interesting problem to discuss the recently discovered resonances, i.e., baryoniums²⁰⁾ and dibaryons²¹⁾ from the view point of our vortex model.

§5. Gauss' theorem on the squeezed magnetic flux

Here we discuss Gauss' theorem for our squeezed magnetic flux with the magnetic charge at its end points. This is most easily examined in the "vortex gauge" of our models:

$$\mathcal{L} = \sum_{\alpha=diag.} \left\{ -\frac{1}{4} (\partial_\mu A'_\nu - \partial_\nu A'_\mu + G_{\mu\nu}^{*\alpha})^2 + \frac{1}{2} m_V^2 A_\mu'^2 \right\}, \quad (5.1a)$$

$$G_{\mu\nu}^\alpha(x) = g_\alpha \iint [y_\mu, y_\nu] \delta^4(x-y) d\tau d\sigma, \quad (5.1b)$$

which is obtained from the Higgs models of §§3 and 4 under the London approximation in our singular gauge, but the $G_{\mu\nu}^*$ is expressed by the gauge transformation U as follows

$$G_{\mu\nu}^* = -\frac{i}{e} U [\partial_\mu, \partial_\nu] U^{-1}. \quad (5.2)$$

First we consider the semi-infinite monopole-vortex system of §3-1, where $g(\equiv g_3) = -4\pi/e$ and the string variables y^μ of (5.1b) are given by the normal frame

$$y^0 = \tau, \quad y^1 = y^2 = 0, \quad y^3 = \sigma. \quad (5.3)$$

The Euler equation of $A_\mu \equiv A_\mu'^3$ is given by

$$\partial^\nu F_{\mu\nu} = m_V^2 A_\mu, \quad (5.4a)$$

$$F_{\mu\nu} \equiv \partial_\mu A_\nu - \partial_\nu A_\mu + G_{\mu\nu}^* . \quad (5.4b)$$

Solving this for A_μ , we obtain⁴⁾

$$\begin{aligned} A_\mu(x) &= -\int \Delta(x-x') \partial^\nu G_{\mu\nu}^*(x') d^4x', \\ (\square + m_V^2) \Delta(x-x') &= -\delta^4(x-x'). \end{aligned} \quad (5.5)$$

Here we shall express the dual tensor $F_{\mu\nu}^*$ in a transparent form for having a physical insight and for proving Gauss' theorem. From (5.1b), (5.4b) and (5.5) we obtain

$$\begin{aligned} F_{\mu\nu}^*(x) &= -\epsilon_{\mu\nu\rho\sigma} \partial^\rho A^\sigma(x) - G_{\mu\nu}(x) \\ &= -\frac{1}{2} \epsilon_{\mu\nu\rho\sigma} \epsilon^{\sigma\alpha\beta\gamma} \partial^\rho \partial_\alpha \int \Delta(x-x') G_{\beta\gamma}(x') d^4x' - G_{\mu\nu}(x) \\ &= \partial_\mu B_\nu(x) - \partial_\nu B_\mu(x) + m_V^2 K_{\mu\nu}(x), \end{aligned} \quad (5.6)$$

where

$$B_\mu(x) \equiv g \int \Delta(x-z) \frac{dz_\mu}{d\tau} d\tau, \quad z_\mu(\tau) \equiv y_\mu(\tau, 0), \quad (5.7)$$

$$K_{\mu\nu}(x) \equiv \int \Delta(x-x') G_{\mu\nu}(x') d^4x'. \quad (5.8)$$

We have used in (5.6) a calculation similar to Ref.6). The τ integration of (5.7) is taken along the world line of the monopole. Note that the expression (5.7) for the $B_\mu(x)$ is modified from the Dirac's one owing to the nonzero mass of A_μ and consequently it has short-range Yukawa-type behavior, e.g., for the monopole at rest

$$B_0(x) = \frac{(-g)}{4\pi} \cdot \frac{e^{-m_V r}}{r}, \quad (5.9)$$

in contrast to the long-range Coulomb potential in the Dirac monopole theory. The new term $m_V^2 K_{\mu\nu}$ in (5.6) which is absent in the Dirac monopole theory presents the confining force between the monopoles. This is easily seen by rewriting the action integral

$$\int \mathcal{L} d^4x = -\frac{1}{2} \int G_{\mu\nu} \partial^\mu B^\nu d^4x - \frac{1}{4} m_V^2 \int G_{\mu\nu} K^{\mu\nu} d^4x. \quad (5.10)$$

The second integral gives the short-range Yukawa interaction between the two surface elements of the world sheet swept out by the Dirac string (the nodal line of the vortex line):

$$-\frac{1}{4} m_V^2 g^2 \int dV dV' \sigma_{\mu\nu}(y) \Delta(y-y') \sigma^{\mu\nu}(y'),$$

$$dV \equiv d\tau d\sigma, \quad dV' \equiv d\tau' d\sigma', \quad \sigma_{\mu\nu}(y) \equiv [y_\mu, y_\nu], \quad (5.11)$$

which gives the confining force between the monopoles and furthermore the action for dual string model⁴⁾. On the other hand, the

first integral of (5.10) gives

$$\frac{1}{2}g^2 \int \dot{z}_\mu \Delta(\mathbf{x}-\mathbf{z}') \dot{z}'^\mu d\tau d\tau',$$

$$\dot{z}_\mu \equiv dz_\mu/d\tau, \quad \dot{z}'^\mu \equiv dz'^\mu/d\tau', \quad (5.12)$$

which is a Yukawa interaction between magnetic currents.

Now we shall discuss Gauss' theorem. In the same manner as the Dirac monopole theory, we obtain from the definition (5.4b) of $F_{\mu\nu}$

$$\partial^\nu F_{\nu\mu}^*(x) = -g \int \frac{dz_\mu}{d\tau} \delta^4(x-\mathbf{z}) d\tau. \quad (5.13)$$

Note that this equation is also derived from (5.6). By setting $\mu = 0$ in (5.13) we obtain

$$\vec{\nabla} \cdot \vec{H} = -g \delta^3(x), \quad (5.14)$$

where $\vec{H} \equiv (F_{01}^*, F_{02}^*, F_{03}^*)$. Thus magnetic Gauss' theorem takes the following form

$$\int_S \vec{H} \cdot d\vec{S} = -g, \quad (5.15)$$

where the surface S encloses the monopole at the origin. It is to be emphasized that any closed surface S enclosing the monopole at the origin can be taken. From (5.6), (5.8) and (5.9), the magnetic field \vec{H} is expressed as follows

$$\vec{H} = \frac{g}{4\pi} \vec{\nabla} \frac{e^{-m_V r}}{r} + \frac{g}{4\pi} \vec{e}_z m_V^2 \int_{-\infty}^0 dz' \frac{e^{-m_V \sqrt{\rho^2 + (z-z')^2}}}{\sqrt{\rho^2 + (z-z')^2}}, \quad (5.16)$$

from which (5.14) is again checked.

From the argument of §3-1 and the expression of \vec{H} in (5.16) we see that the magnetic flux originates from the monopole at the origin in two distinct forms. One with squeezed flux tube with radius m_V^{-1} along the negative z-axis extends to the infinity $z \rightarrow -\infty$. The other extends spherically like Yukawa force of range m_V^{-1} . The independence of (5.15) of the surface S is explicitly verified by evaluating the left-hand side of (5.15) about a small sphere S_ϵ and a large sphere S_R centered at the origin (Fig.9). For the sphere S_ϵ ($0 < \epsilon \ll m_V^{-1}$), we have

$$\begin{aligned} \int_{S_\epsilon} \vec{H} \cdot d\vec{S} &= \frac{g}{4\pi} \int \vec{\nabla} \frac{1}{r} \cdot d\vec{S} \\ &= -g. \end{aligned} \quad (5.17)$$

For the sphere S_R ($R \gg m_V^{-1}$), the first term of (5.16) can be neglected and we obtain

$$\int_{S_R} \vec{H} \cdot d\vec{S} = \frac{g}{4\pi} m_V^2 \int \vec{e}_z \cdot d\vec{S} \int_{-\infty}^0 dz' \frac{e^{-m_V \sqrt{\rho^2 + (z-z')^2}}}{\sqrt{\rho^2 + (z-z')^2}}. \quad (5.18)$$

Since the main contribution to the surface integral comes from the region $\pi \geq \theta \geq m_V^{-1}/R$ around the south pole of the S_R , we get

$$\int_{S_R} \vec{H} \cdot d\vec{S} = -\frac{g}{4\pi} m_V^2 \int_{0 \leq \rho \leq m_V^{-1}} dx dy \int_{-\infty}^R du \frac{e^{-m_V \sqrt{x^2 + y^2 + u^2}}}{\sqrt{x^2 + y^2 + u^2}}, \quad (5.19)$$

where we have legitimately replaced the surface integral on the S_R by the one on the plane $z = -R$ and introduced the new variable of the integration: $u = R + z'$. The integral of (5.19) is easily evaluated by extending the region of the integration to the whole region of the variables x, y and u . Finally we get

$$\begin{aligned} \int_{S_R} \vec{H} \cdot d\vec{S} &= -\frac{g}{4\pi} m_V^2 \int_{-\infty}^{+\infty} dx dy du \frac{e^{-m_V \sqrt{x^2 + y^2 + u^2}}}{\sqrt{x^2 + y^2 + u^2}} \\ &= -g. \end{aligned} \quad (5.20)$$

Thus we can justify that the flux originates from the monopole at the origin and extends along the negative z -axis to the infinity $z \rightarrow -\infty$ in the form of squeezed vortex line of radius m_V^{-1} . Similar result can be also obtained for the finite system of §3-2.

So far we have used the singular "vortex gauge". In order to make the gauge invariance of our argument manifest, an appropriate gauge-invariant field strength $\mathcal{F}_{\mu\nu}$ must be introduced and the magnetic flux should be defined with this gauge-invariant field strength. For the above $SU(2)$ case, the $\mathcal{F}_{\mu\nu}$ can be defined as

$$\mathcal{F}_{\mu\nu} = \hat{Q}^a F_{\mu\nu}^a, \quad \vec{\hat{Q}} \equiv \vec{\hat{\phi}} \times \vec{\hat{\psi}}, \quad (5.21)$$

which is reduced to $F_{\mu\nu}^{'3} = \partial_{\mu} A_{\nu}^{'3} - \partial_{\nu} A_{\mu}^{'3} + G_{\mu\nu}^{'3}$ in the "vortex gauge" of §3. The $A \times A$ term of $F_{\mu\nu}^{'3}$ vanishes, because only the diagonal component of the gauge potential $A_{\mu}^{'3}$ remains in this gauge. This term can not be neglected in the exact solution, however.

Next we discuss the SU(3) finite system of §4-1. We have obtained, in our "vortex gauge", the approximate solution (4-1.11) where only the diagonal components $A_{\mu}^{'3}$ and $A_{\mu}^{'8}$ remain. In this SU(3) case, two magnetic fluxes are defined in (4-1.17) through two gauge-invariant field strengths (see (4-1.14) and (4-1.16))

$$\begin{aligned} \mathcal{F}_{\mu\nu}^{\text{I}} &= 2 \text{Tr}(\hat{\Phi}^{(2)2} - \hat{\Phi}^{(3)2}) F_{\mu\nu}, \\ \mathcal{F}_{\mu\nu}^{\text{II}} &= \frac{2}{\sqrt{3}} \text{Tr}(2\hat{\Phi}^{(1)2} - \hat{\Phi}^{(2)2} - \hat{\Phi}^{(3)2}) F_{\mu\nu}, \end{aligned} \quad (5.22)$$

for the case (a) of Table 1 and the indices I and II are interchanged in (5.22) for the case (b) of Table 1. In what follows, we shall mention only the case (a) of Table 1 for simplicity. By $\mathcal{F}_{\mu\nu}^{\text{I}}$ and $\mathcal{F}_{\mu\nu}^{\text{II}}$ we define the 'color' magnetic charges $g_{\text{I}} = -\hat{\phi}_{\text{I}}$ and $g_{\text{II}} = -\hat{\phi}_{\text{II}}$ for red, blue and green quarks (see (4-1.17) and Table 1). When the Higgs scalars $\hat{\phi}^{(i)}$ take the values

$$\hat{\phi}^{(1)} = \frac{\lambda^1}{2}, \quad \hat{\phi}^{(2)} = \frac{\lambda^4}{2}, \quad \hat{\phi}^{(3)} = \frac{\lambda^6}{2}, \quad (5.23)$$

in the "vortex gauge", these fields $\mathcal{F}_{\mu\nu}^I$ and $\mathcal{F}_{\mu\nu}^{II}$ are reduced to

$$\begin{aligned}\mathcal{F}_{\mu\nu}^I &= F_{\mu\nu}^{\prime 3} = \partial_\mu A_\nu^{\prime 3} - \partial_\nu A_\mu^{\prime 3} + G_{\mu\nu}^{*3}, \\ \mathcal{F}_{\mu\nu}^{II} &= F_{\mu\nu}^{\prime 8} = \partial_\mu A_\nu^{\prime 8} - \partial_\nu A_\mu^{\prime 8} + G_{\mu\nu}^{*8},\end{aligned}\tag{5.24}$$

from which we obtain (4-1.18a).

The magnetic fields of the SU(3) finite system are

$$\begin{aligned}\vec{H}_I &= \frac{3\beta}{2e} \left[\vec{\nabla} \frac{\bar{e}^{-m_V r}}{r} + \vec{e}_z m_V^2 \int_{-a}^a dz' \frac{\bar{e}^{-m_V \sqrt{\rho^2 + (z-z')^2}}}{\sqrt{\rho^2 + (z-z')^2}} \right], \\ \vec{H}_{II} &= \frac{\sqrt{3}(\beta-\alpha)}{2e} \left[\vec{\nabla} \frac{\bar{e}^{-m_V r}}{r} + \vec{e}_z m_V^2 \int_{-a}^a dz' \frac{\bar{e}^{-m_V \sqrt{\rho^2 + (z-z')^2}}}{\sqrt{\rho^2 + (z-z')^2}} \right].\end{aligned}\tag{5.25}$$

From similar argument to the SU(2) case, we see that the two fluxes Φ_I and Φ_{II} originate from the monopole at \vec{a}_+ and are squeezed into the flux tube with radius m_V^{-1} along the interval $x = y = 0, -a \leq z \leq a$ and terminate at the antimonopole at \vec{a}_- .

In order to define the SU(3) gauge-invariant field strengths which can be reduced to $\partial_\mu A_\nu^{\prime\alpha} - \partial_\nu A_\mu^{\prime\alpha} + G_{\mu\nu}^{*\alpha}$, $\alpha = 3, 8$ without any approximation, we may add certain polynomial of $D_\mu \hat{\phi}^{(i)}$ to the right-hand side of the field strengths (5.22).¹⁷⁾

§6. The quark confinement in our SU(3) Higgs model

In the previous sections §§4-1 and 4-2, we have constructed the meson systems $R\bar{R}$, $B\bar{B}$ and $G\bar{G}$ and Y-shaped (or Δ -shaped) baryon system RBG. Two important properties for confinement by magnetic vortices are

- (i) vortices start from positive 'color' magnetic charge and terminate at negative 'color' magnetic charge.
- (ii) the energy stored in the magnetic vortices per unit length is constant.

From these properties of vortices, we can conclude that for the finite energy system (equivalently finite-size system) the two kinds of I and II vortices are 'closed' within its system. By what is 'closed', we mean that the vortices start from one quark (antiquark) with $+(-)$ 'color' charge and terminate at another quark (antiquark) with $-(+)$ 'color' charge in the same system. For $R\bar{R}$, $B\bar{B}$ and $G\bar{G}$ meson systems and Y-shaped (or Δ -shaped) RBG baryon system of §§4-1 and 4-2, the vortices are closed and the energies of these systems are finite. Contrary to these, however, the diquark and isolated quark systems have infinite energies, because at least one vortex must extend to infinity. For example in RB system, two II vortices start from R and B to infinite points, because both R and B have plus charge for II vortex. It can never be realized in any process of finite energy.

We thus see that our I and II vortex lines correspond to the vortex bonds of Nambu's phenomenological chemical bond model for hadrons.^{5),18)} These bonds allow only 'colorless' states such

as $R\bar{R}$, $B\bar{B}$ and $G\bar{G}$ meson states and RGB baryon state as finite-energy states. By 'colorless' states, we shall mean such systems as those with no magnetic 'color' charge. It should be noted that our model can allow some exotic states such as baryonium $R\bar{R}B\bar{B}$ (M_4^2) and dibaryon $R^2B^2G^2$ (D_6^4) (Fig.10). The finite-energy states are

- (i) 'colorless' mesons: $R\bar{R}$, $B\bar{B}$, $G\bar{G}$,
- (ii) 'colorless' baryons (antibaryons): $RGB(\bar{R}\bar{B}\bar{G})$,
- (iii) 'colorless' exotic states: $R\bar{R}B\bar{B}$, $R^2B^2G^2$ etc.,
- (iv) Pomeron⁵⁾ (Fig.11).

All other systems such as 'colored' mesons, 'colored' baryons, diquarks, isolated quarks, and 'colored' exotic states, e.g., $RRBB$ are excluded in our model. We see that the confinement of quarks, in this chemical vortex bond model, can be explained at least for 'colorless' states but does not necessarily select the 'color' singlet hadron states. It is interesting to study experimentally the difference between the 'colorless' states in our model and the color singlet states in the conventional color model. Further analysis is required on this point.

§7. Conclusion and final remarks

We have shown that Nambu's conjecture on color chemical bond can be justified by the vortex solution of SU(3) nonabelian gauge field with Higgs scalars. One of the important tasks to construct a chemical-bond-like model for hadron, is to find the vortex solution of finite length in the SU(3) nonabelian gauge field with Higgs scalars. We have succeeded in finding a vortex solution of finite length, though in London approximation. The first problem in constructing the vortex solution is to ask how to construct the supercurrent which preserves the magnetic vortex of finite size. We can construct such supercurrent by introducing a singular unitary matrix U , namely the supercurrent of Higgs scalars of the type $F^{(i)} U^{-1} T^{(i)} U$. One of the easiest way to find the vortex solution of Euler equations is to apply the unitary transformation U . The Euler equations become much simplified, and further a Dirac string singularity appears through the gauge term $U^{-1} [\partial_\mu, \partial_\nu] U$, which is a string source term for the vortex solution. This equation of gauge potential is just what Nambu has conjectured to derive his chemical-bond-like model. Thus our vortex solution gives the mathematically rigorous foundation to Nambu's conjecture. One of the advantages of our model is to derive the dual string action quite naturally. We introduce two gauge invariant 'color' fluxes $\text{Tr}(\hat{\Phi}^{(2)2} - \hat{\Phi}^{(3)2}) F_{\mu\nu}$ and $\text{Tr}(2\hat{\Phi}^{(1)2} - \hat{\Phi}^{(2)2} - \hat{\Phi}^{(3)2}) F_{\mu\nu}$. By these two 'color' (magnetic) fluxes we can define red, blue, and green quarks, and thus we have succeeded in constructing a 'color'-chemical-bond model.

One of the problems left unsolved is how to attach the fermion (anti-) quark at each end of magnetic vortex. Our model is quite different from other confinement models, in that our model selects only 'colorless' states in the sense defined in §4.

Note that the vortex lines of our meson and baryon systems of §§3 and 4 have no topological stability, because the monopoles (antimonopoles) at their ends have no Dirac string singularity in the regular gauge, and according to Tze and Ezawa's argument¹¹⁾, only the topologically unstable vortex lines admit singularity-free end points. This is also checked by evaluating explicitly the nonintegrable phase factor $\Omega_C(2\pi) = \text{Tr} \exp(i e \oint_C A_\mu dx^\mu)$, where C is the closed loop of the radius $\rho \gg m_V^{-1}$ encircling the vortex line. For the completely broken $SU(N)/Z_N$ gauge symmetry, the value of $\Omega_C(2\pi)$ is restricted to the discrete elements of the $SU(N)$ center Z_N and discriminates the topologically distinct classes of vortex lines. Especially $\Omega_C(2\pi) = \mathbb{1}$ corresponds to the topologically unstable class. Since we can obtain $\Omega_C(2\pi) = \mathbb{1}$ for the vortex lines of §§3 and 4, they belong to the topologically unstable class. In any case, however, the topological stability of our finite meson as a whole cannot be derived since the total topological charge of the system is always zero. Furthermore, for our baryon, we cannot obtain any nonzero total topological charge (e.g., the baryon number), and therefore their topological stability does not seem to exist. In this paper we have restricted ourselves only to the monopole-vortex systems in which no Dirac string singularity exists in the regular gauge. Consequently we have obtained the topologically unstable vortex lines. We can extend our argument to the case of topologically stable vortex lines by introducing explicitly

the Dirac string singularity which cannot be removed by any singular gauge transformations. For a more mathematically suitable treatment of these systems, we can use Wu and Yang's theory²²⁾ of magnetic monopoles based on the theory of fibre bundles,²³⁾ in which no string singularity is introduced.

Our model can be easily generalized to construct vortex solutions of any shape. We have only to find an appropriate singular unitary matrix U , which generates the supercurrent that preserves the vortex of given shape. These generalized solutions enable us to discuss the recently discovered resonances, i.e., baryoniums²⁰⁾ and dibaryons.²¹⁾ It is a very interesting problem to test whether our magnetic vortex model is more favorable than others, such as Susskind's lattice model.²⁴⁾

Our model is the only simple quark confinement model which can explain the dual string action. The lattice gauge model is a very promising one in this respect, but at present this model is not successful in explaining the dual string action.

Acknowledgement

The author is greatly indebted to Professor Y. Miyamoto for many invaluable suggestions and discussions on the whole stage of this work, and also for careful reading of the manuscript. The author also thanks Professor S. Kamefuchi, Professor Y. Hara, and Professor Y. Iwasaki for their valuable comments.

Appendix A: Notation

Our metric is $g_{00} = -g_{11} = -g_{22} = -g_{33} = 1$. Repeated Greek indices are summed from 0 to 3; Latin indices from 1 to 3. Generally, the indices i, j and k refer to ordinary space, a to SU(2) space, and α to SU(3) space. The total antisymmetric tensor ϵ_{ijk} is normalized as $\epsilon_{123} \equiv 1$. The dual of an antisymmetric tensor $A_{\mu\nu}$ is defined by $A_{\mu\nu}^* = -(1/2)\epsilon_{\mu\nu\rho\sigma}A^{\rho\sigma}$, with the total antisymmetric tensor $\epsilon_{0123} \equiv 1$. Magnetic field H is defined as $H^i = -(1/2)\epsilon_{ijk}F^{jk}$, i.e., $\vec{H} = (F_{01}^*, F_{02}^*, F_{03}^*) = (F_{32}, F_{13}, F_{21})$. In our notation, the magnetic flux Φ which originates from a monopole with strength g is given by $\Phi = -g$.

Appendix B: The unitary gauge of the SU(3) model of §4

In this appendix, we define the unitary gauge of the SU(3) model of §4. Because of the SU(3) symmetry, it is sufficient to restrict ourselves to the Higgs scalars

$$\Phi_0^{(1)} = F \frac{\lambda^1}{2}, \quad \Phi_0^{(2)} = F \frac{\lambda^4}{2}, \quad \Phi_0^{(3)} = F \frac{\lambda^6}{2}, \quad (\text{B-1})$$

instead of (4-1.5). Since $\Phi_0^{(i)}$'s of (B-1) satisfy the relations

$$\text{Tr} \Phi^{(i)2} = \frac{1}{2} F^2, \quad i = 1, 2, 3, \quad (\text{B-2})$$

and

$$\left\{ \Phi_0^{(i)}, \Phi_0^{(j)} \right\} = \frac{1}{2} F \Phi_0^{(k)} \quad (\text{B-3})$$

with $(i, j, k) = (1, 2, 3), (2, 3, 1),$ and $(3, 1, 2),$ we see that the $\Phi_0^{(i)}$'s give the minimum of the Higgs potential $V(\Phi)$ (≥ 0) of (4-1.2), i.e., $V(\Phi) = 0$. When we write the Higgs scalars around the minimum state $\Phi_0^{(i)}$'s as

$$\Phi^{(i)} = \Phi_0^{(i)} + \delta\Phi^{(i)}, \quad i = 1, 2, 3, \quad (\text{B-4})$$

we obtain $\delta V(\Phi) = 0$ and, for the second order variation, we obtain

$$\begin{aligned} \delta^2 V(\Phi) &= 4c_1 \sum_{i=1}^3 \left(\text{Tr} \Phi_0^{(i)} \delta\Phi^{(i)} \right)^2 \\ &+ c_2 \sum_{\text{cyclic}} \text{Tr} \left(\left\{ \Phi_0^{(i)}, \delta\Phi^{(j)} \right\} + \left\{ \Phi_0^{(j)}, \delta\Phi^{(i)} \right\} - \frac{1}{2} F \delta\Phi^{(k)} \right)^2 \geq 0. \end{aligned} \quad (\text{B-5})$$

Obviously, from the SU(3) invariance of the $V(\Phi)$, there always exist the nontrivial $\delta\Phi^{(i)}$'s which lead to $\delta^2 V = 0$. Conversely,

we can prove that the nontrivial $\delta\Phi^{(i)}$'s which lead to $\delta^2V = 0$ are restricted to those which are obtained by applying a suitable SU(3) transformation to the $\Phi_0^{(i)}$'s. This is seen as follows. From (B-5), the nontrivial $\delta\Phi^{(i)}$'s which lead to $\delta^2V = 0$ must satisfy the equations

$$\text{Tr} \Phi_0^{(i)} \delta\Phi^{(i)} = 0 \quad , \quad i = 1, 2, 3, \quad (\text{B-6})$$

$$\{\Phi_0^{(i)}, \delta\Phi^{(j)}\} + \{\Phi_0^{(j)}, \delta\Phi^{(i)}\} - \frac{1}{2} \text{Tr} \delta\Phi^{(k)} = 0 \quad , \quad (\text{B-7})$$

from which we obtain

$$\begin{aligned} \delta\Phi^{(1)1} &= 0 \quad , & \delta\Phi^{(2)1} &= -\delta\Phi^{(1)4} \quad , & \delta\Phi^{(3)1} &= -\delta\Phi^{(1)6} \quad , \\ \delta\Phi^{(1)8} &= 0 \quad , & \delta\Phi^{(2)2} &= \delta\Phi^{(1)5} \quad , & \delta\Phi^{(3)2} &= -\delta\Phi^{(1)7} \quad , \\ & & \delta\Phi^{(2)3} &= -\delta\Phi^{(1)6} \quad , & \delta\Phi^{(3)3} &= \delta\Phi^{(1)4} \quad , \\ & & \delta\Phi^{(2)4} &= 0 \quad , & \delta\Phi^{(3)4} &= \frac{1}{2} \delta\Phi^{(1)3} \quad , & (\text{B-8}) \\ & & \delta\Phi^{(2)6} &= -\frac{1}{2} \delta\Phi^{(1)3} \quad , & \delta\Phi^{(3)5} &= \delta\Phi^{(2)7} \quad , \\ & & \delta\Phi^{(2)8} &= -\sqrt{3} \delta\Phi^{(1)6} \quad , & \delta\Phi^{(3)6} &= 0 \quad , \\ & & & & \delta\Phi^{(3)7} &= -\delta\Phi^{(1)2} + \delta\Phi^{(2)5} \quad , \\ & & & & \delta\Phi^{(3)8} &= -\sqrt{3} \delta\Phi^{(1)4} \quad , \end{aligned}$$

where eight of the unknown components, i.e., $\delta\Phi^{(1)2-7}$ and $\delta\Phi^{(2)5,7}$, cannot be determined. It is easily seen that $\delta\Phi^{(i)}$'s of (B-8) are

obtained from the $\phi_0^{(i)}$'s through the SU(3) transformation

$$U = \exp\left(i \frac{\lambda^\alpha}{2} \theta^\alpha\right) \quad (\text{B-9a})$$

with

$$\begin{aligned} (\theta^\alpha) = & \left(-2\delta\Phi^{(2)7}, \delta\Phi^{(1)3}, -\delta\Phi^{(1)2}, 2\delta\Phi^{(1)7}, -2\delta\Phi^{(1)6}, 2\delta\Phi^{(1)5}, \right. \\ & \left. -2\delta\Phi^{(1)4}, \frac{1}{\sqrt{3}}\delta\Phi^{(1)2} - \frac{2}{\sqrt{3}}\delta\Phi^{(2)5} \right). \end{aligned} \quad (\text{B-9b})$$

In order to introduce the unitary gauge, we parametrize the Higgs scalars around the $\phi_0^{(i)}$'s as

$$\Phi^{(1)} = \frac{1}{2} F V(\xi) \left\{ \lambda^1 (1 + \eta^{(1)1}) + \lambda^8 \eta^{(1)8} \right\} V(\xi)^{-1},$$

$$\Phi^{(2)} = \frac{1}{2} F V(\xi) \left\{ \lambda^1 \eta^{(2)1} + \lambda^2 \eta^{(2)2} + \lambda^3 \eta^{(2)3} + \lambda^4 (1 + \eta^{(2)4}) + \lambda^6 \eta^{(2)6} + \lambda^8 \eta^{(2)8} \right\} V(\xi)^{-1} \quad (\text{B-10a})$$

$$\begin{aligned} \Phi^{(3)} = & \frac{1}{2} F V(\xi) \left\{ \lambda^1 \eta^{(3)1} + \lambda^2 \eta^{(3)2} + \lambda^3 \eta^{(3)3} + \lambda^4 \eta^{(3)4} + \lambda^5 \eta^{(3)5} + \lambda^6 (1 + \eta^{(3)6}) \right. \\ & \left. + \lambda^7 \eta^{(3)7} + \lambda^8 \eta^{(3)8} \right\} V(\xi)^{-1}, \end{aligned}$$

where

$$V(\xi) = \exp\left(i \frac{\lambda^\alpha}{2} \xi^\alpha\right). \quad (\text{B-10b})$$

The eight ξ 's and sixteen η 's denote the new independent fields which parametrize the Higgs scalars around the $\phi_0^{(i)}$'s. We now make the gauge transformation defined by

$$\Phi^{(i)'} = V^{-1} \Phi^{(i)} V, \quad i=1, 2, 3,$$

(B-11)

$$A_{\mu}' = V^{-1} A_{\mu} V - \frac{i}{e} \partial_{\mu} V^{-1} \cdot V .$$

In this unitary gauge, the fields ξ which correspond to the unphysical massless Goldstone bosons are gauged away and are absorbed into the longitudinal components of the gauge potentials A_{μ}^{α} . Furthermore all the η 's are massive, since we can obtain nonvanishing determinant for the mass matrix of η 's. There remain, therefore, only massive particles: eight massive vector fields and the sixteen massive scalars $\eta^{(1)\alpha}$, $\eta^{(2)\alpha}$, and $\eta^{(3)\alpha}$.

References

- 1) M-Y. Han and Y. Nambu, Phys. Rev. 139 (1965), B1006.
- 2) Y. Miyamoto, Prog. Theor. Phys. Suppl., Commemoration Issue for the 30th Anniversary of the Meson theory by Dr. H. Yukawa, (1965) 187.
- 3) H. B. Nielsen and P. Olesen, Nucl. Phys. B61 (1973), 45.
- 4) Y. Nambu, Phys. Rev. D10 (1974), 4262.
- 5) Y. Nambu, EFI preprint 74/03, Talk presented at the Johns Hopkins Workshop on Current Problems in High Energy Particle Theory, January, 1974.
- 6) P. A. M. Dirac, Phys. Rev. 74 (1948), 817.
- 7) R. Brout, F. Englert and W. Fischler, Phys. Rev. Letters 36 (1976), 649.
- 8) M. Kamata, Prog. Theor. Phys. 59 (1978), 1346.
- 9) G. 't Hooft, Nucl. Phys. B79 (1974), 276.
A. M. Polyakov, JETP Letters 20 (1974) 194.
- 10) J. Arafune, P. G. O. Freund and C. J. Goebel, J. Math. Phys. 16 (1975), 433.
- 11) H. C. Tze and Z. F. Ezawa, Phys. Rev. D14 (1976), 1006.
- 12) S. Coleman, Classical Lumps and their Quantum Descendants, Erice Lectures 1975.
- 13) S. Mandelstam, Phys. Letters 53B (1975), 476.
- 14) C. G. Bollini and J. J. Giambiagi, Nucl. Phys. B123 (1977), 311.
- 15) A. Patkós, Nucl. Phys. B97 (1975), 352.
A. Jevicki and P. Senjanović, Phys. Rev. D11 (1975), 860.
- 16) M. Wadati, H. Matsumoto and H. Umezawa, Phys. Rev. D18 (1978), 520.

- 17) A. Sinha, Phys. Rev. D14 (1976), 2016.
- 18) A. Patkós, Nucl. Phys. B129 (1977), 339.
- 19) M. Imachi, S. Otsuki and F. Toyoda, Progr. Theor. Phys. 55 (1976) 551, 57 (1977) 517.
F. Toyoda and M. Uehara, Progr. Theor. Phys. 58 (1977), 1456.
M. Imachi and S. Otsuki, Progr. Theor. Phys. 58 (1977) 1657, 1660.
G. C. Rossi and G. Veneziano, Nucl. Phys. B123 (1977), 507.
- 20) A. S. Carroll et al., Phys. Rev. Letters 32 (1974), 247.
V. Chaloupka et al., Phys. Letters 61B (1976), 487.
W. Brückner et al., Phys. Letters 67B (1977), 222.
- 21) I. P. Auer et al., Phys. Letters 67B (1977), 113, 70B (1977) 475 and 479.
- 22) T. T. Wu and C. N. Yang, Phys. Rev. D12 (1975), 3845.
- 23) N. Steenrod, The Topology of Fibre Bundles (Princeton Univ. Press, Princeton, N.J., 1951).
- 24) J. Kogut and L. Susskind, Phys. Rev. D11 (1975), 395.

Table Caption

Tables 1(a) and (b) . Typical values of α , β and γ which fulfill (4-1.13) with the condition $\alpha + \beta + \gamma = 0$, and the values of g_I and g_{II} for red, blue and green quarks (monopoles). The g_I and g_{II} of the case (a) ((b)) are equal to the $g_{3(8)}$ and $g_{8(3)}$ of (4-1.12) respectively.

Figure Captions

- Fig.1(a). Lines of magnetic force in the case of 't Hooft-Polyakov monopole.
- 1(b). Lines of magnetic force in the case of 't Hooft-Polyakov monopole-antimonopole system.
- Fig.2(a). Squeezed magnetic flux tube of semi-infinite length in a superconducting vacuum.
- 2(b). Squeezed magnetic flux tube of finite length in a superconducting vacuum.
- Fig.3. A semi-infinite monopole-vortex system.
- Fig.4. A finite monopole-antimonopole system.
- Fig.5. A relation between the semi-infinite system of Fig.3 and the finite system of Fig.4. The vertex angle δ approaches the zenith angle θ under the limit $a \rightarrow \infty$.
- Fig.6. 'Colorless' mesons $R\bar{R}$, $B\bar{B}$ and $G\bar{G}$. Solid and dashed lines represent I and II vortex lines, respectively.
- Fig.7. A Y-shaped baryon. (1)-vortex line consisting of both I and II vortex lines is taken to be parallel to the z-axis. The y-axis is perpendicular to the paper.
- Fig.8. A Δ -shaped baryon, where double arrows represent the vortex lines of the two units of magnetic fluxes.
- Fig.9. Small sphere S_ϵ ($0 < \epsilon \ll m_V^{-1}$) and large sphere S_R ($R \gg m_V^{-1}$) in the semi-infinite monopole-vortex system, where the solid lines represent the lines of magnetic force schematically.
- Fig.10. 'Colorless' exotic baryonium state $R\bar{R}B\bar{B}$ (M_4^2) and dibaryon state $R^2B^2G^2$ (D_6^4).
- Fig.11. A Pomeron.

(a)	'Color'	(α , β , γ)	g_I/g_{I_0}	g_{II}/g_{II_0}
	Red	(-1, 1, 0)	1	1
	Blue	(0, -1, 1)	-1	1
	Green	(1, 0, -1)	0	-2

$$g_{I_0} \equiv 6\pi/e, \quad g_{II_0} \equiv 2\sqrt{3}\pi/e$$

(b)	'Color'	(α , β , γ)	g_I/g_{I_0}	g_{II}/g_{II_0}
	Red	(1/3, 1/3, -2/3)	1	1
	Blue	(-2/3, 1/3, 1/3)	-1	1
	Green	(1/3, -2/3, 1/3)	0	-2

$$g_{I_0} \equiv 2\sqrt{3}\pi/e, \quad g_{II_0} \equiv 2\pi/e$$

Table 1

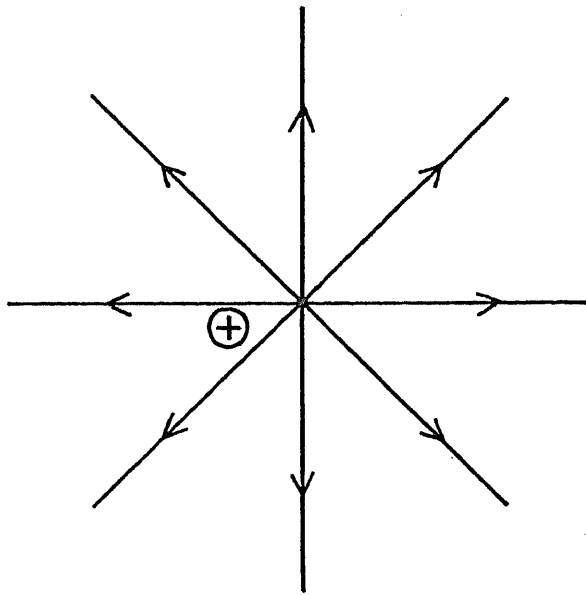

(a)

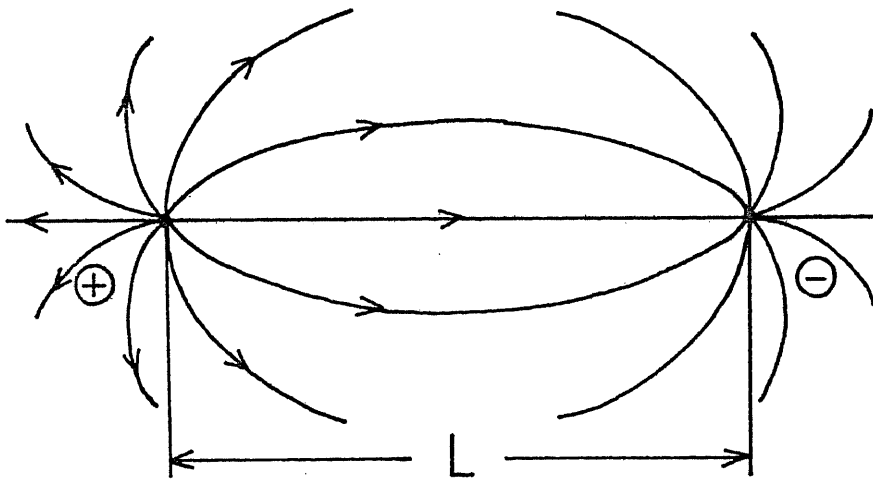

(b)

Fig.1

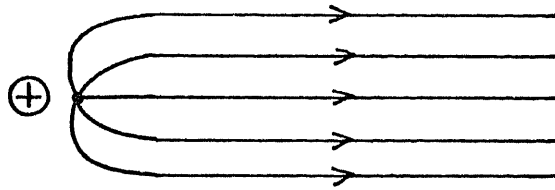

(a)

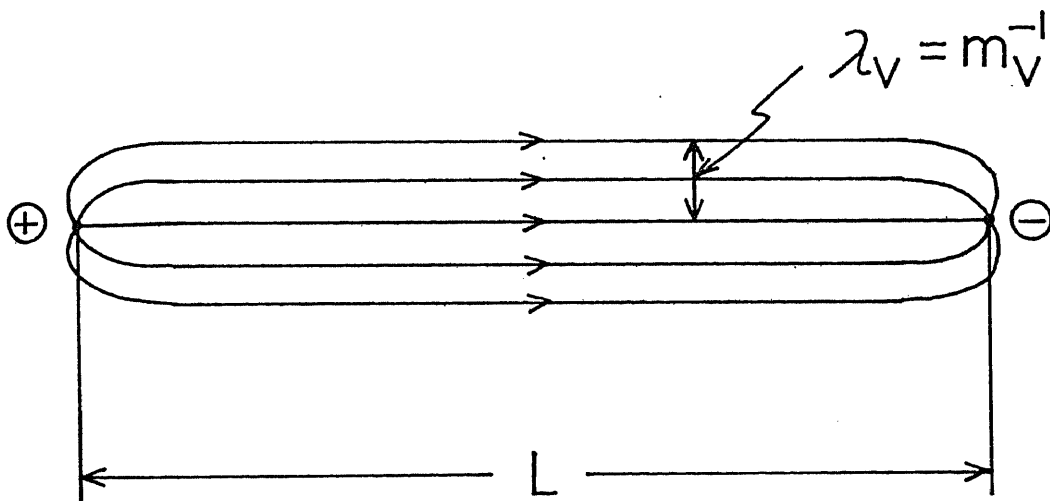

(b)

Fig. 2

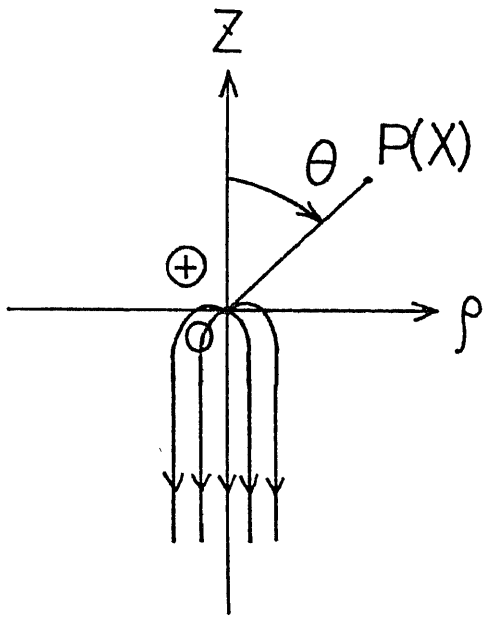

Fig. 3

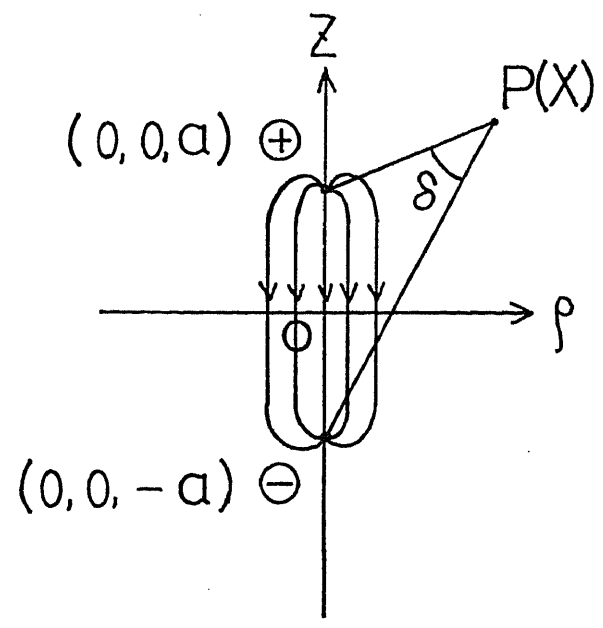

Fig. 4

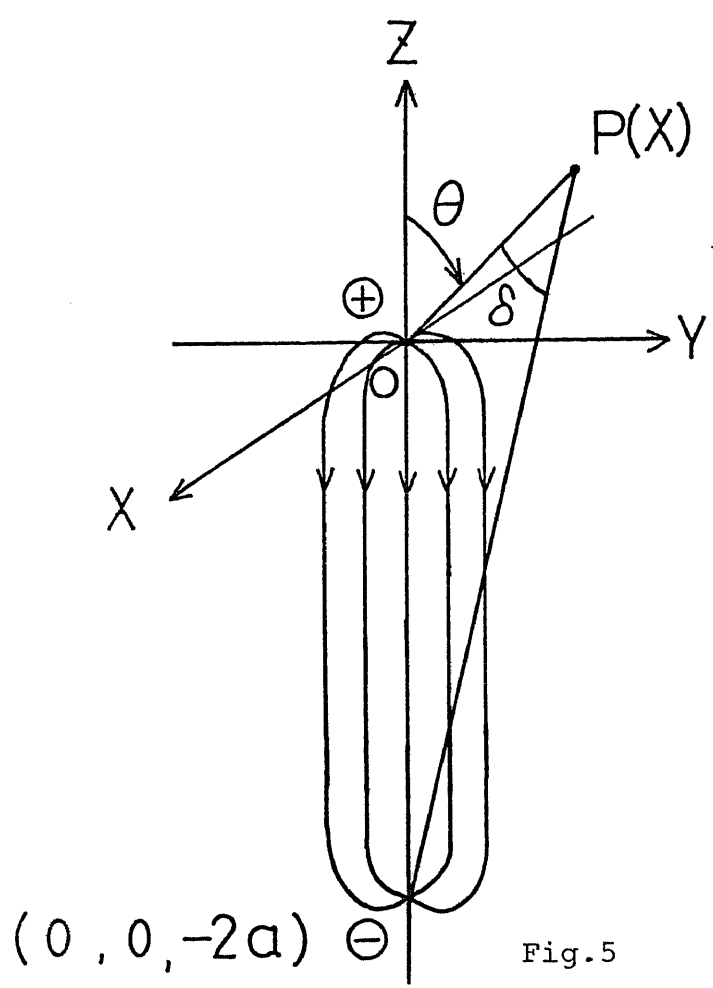

Fig. 5

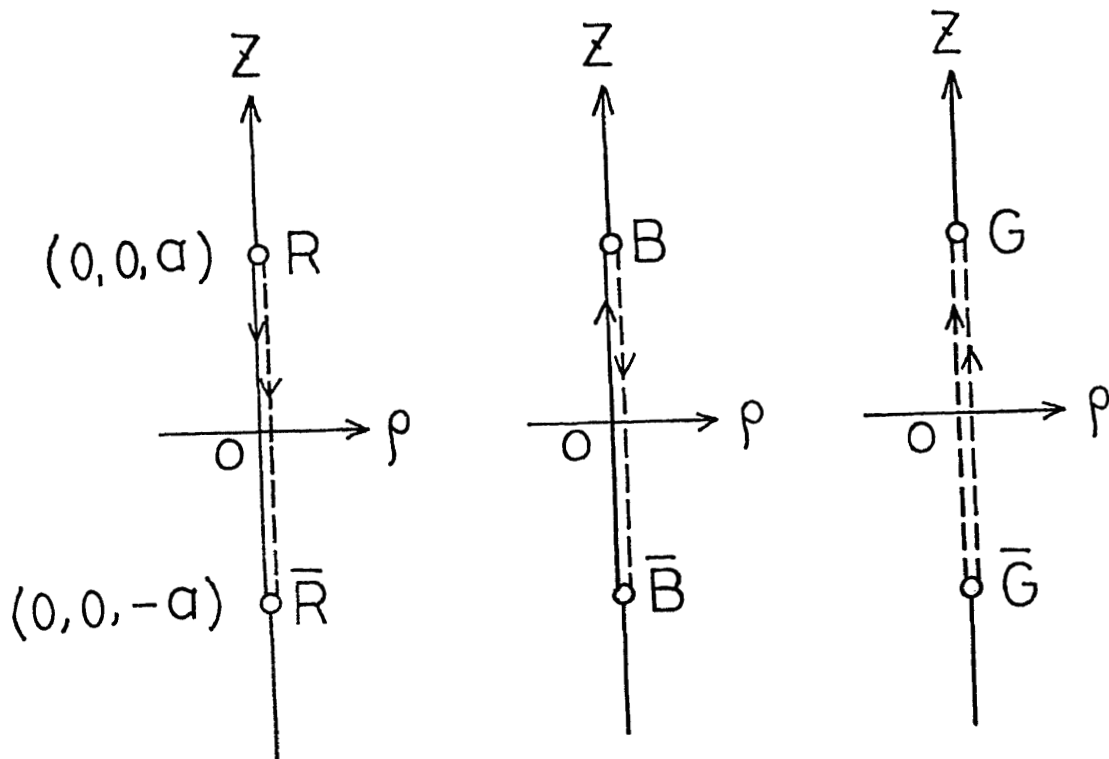

Fig. 6

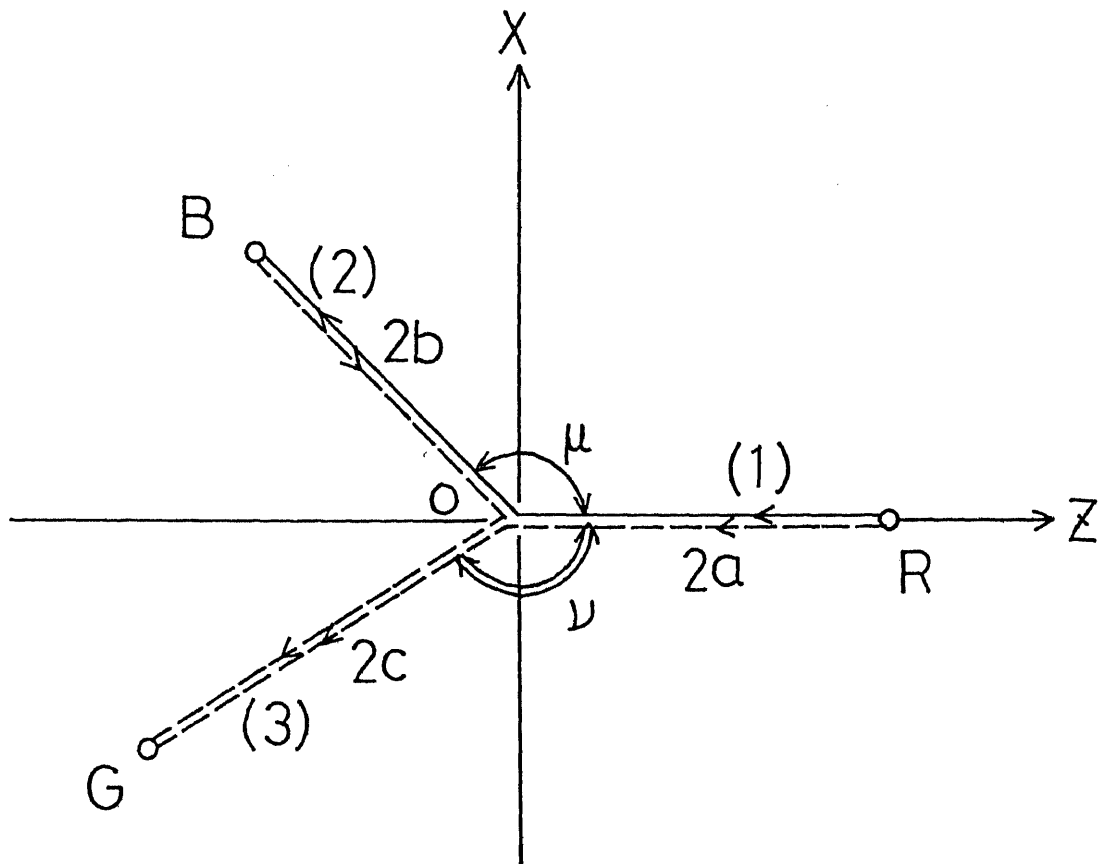

Fig. 7

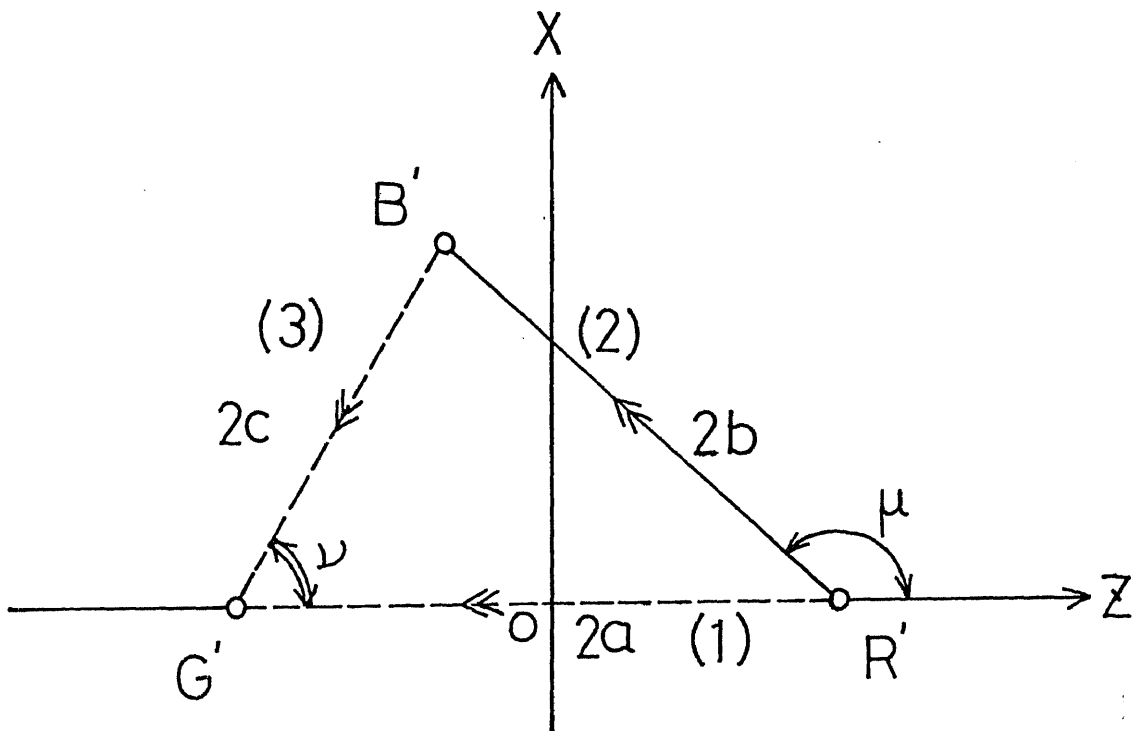

Fig. 8

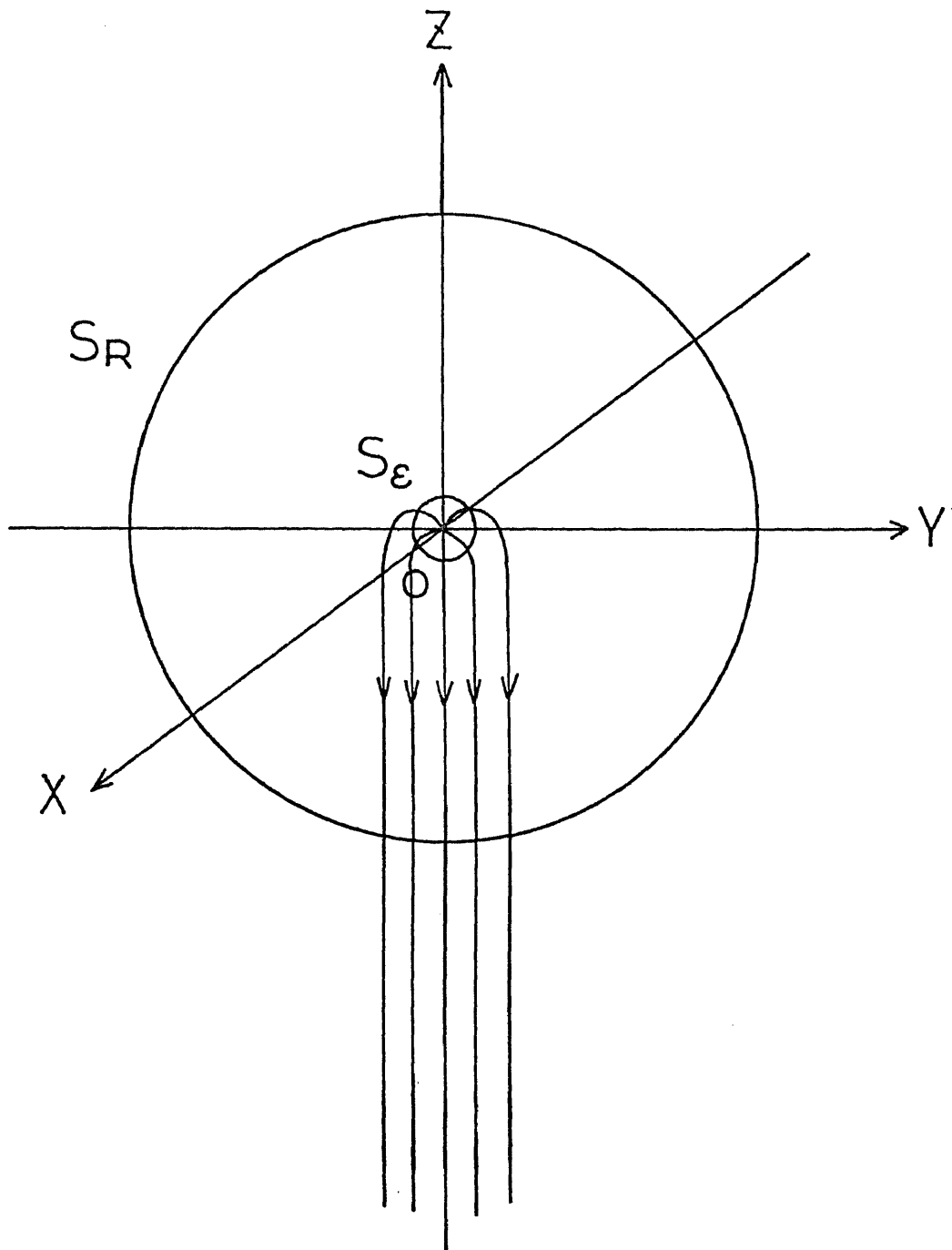

Fig.9

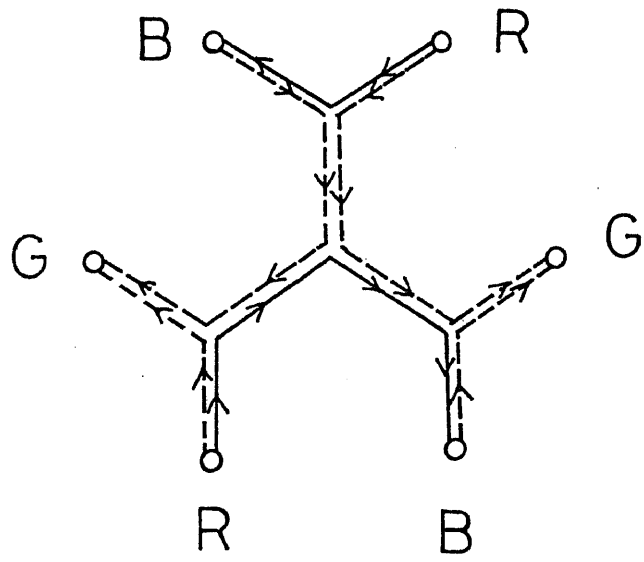
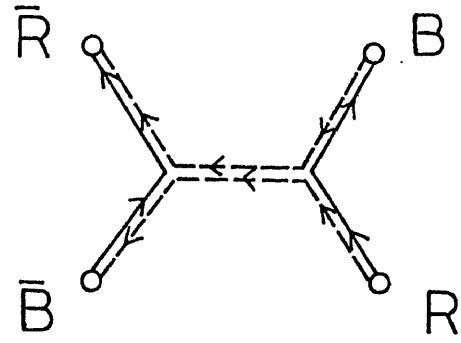

Fig.10

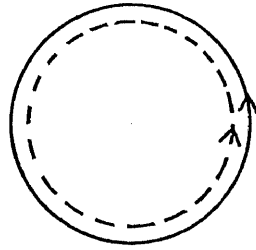

Fig.11