

The role of mindfulness in performance and mental health among Japanese athletes: An examination of the relationship between alexithymic tendencies, burnout, and performance

著者 (英)	Rei AMEMIYA, Yosuke SAKAIRI
journal or publication title	Journal of Human Sport and Exercise
volume	14
number	2
page range	456-468
year	2019-06
権利	(C) Faculty of Education. University of Alicante This work is licensed under a Attribution-NonCommercial-NoDerivatives 4.0 International(CC BY-NC-ND 4.0).
URL	http://hdl.handle.net/2241/00159182

doi: 10.14198/jhse.2019.142.17

The role of mindfulness in performance and mental health among Japanese athletes: An examination of the relationship between alexithymic tendencies, burnout, and performance

REI AMEMIYA , YOSUKE SAKAIRI

Faculty of Health and Sport Sciences, University of Tsukuba, Japan

ABSTRACT

The purpose of this study was to investigate the relationships between mindfulness, alexithymia, burnout, and performance efficacy among athletes by means of a longitudinal survey. Participants were 125 university athletes (74 men, 50 women, 1 unknown gender; mean age: 19.84 years, SD = 1.04) who completed a survey comprising the Athlete Mindfulness Questionnaire, Sport Alexithymia Scale, Burnout Scale for University Athletes, and Psychological Performance Efficacy Scale (on which they assessed both themselves and a teammate) at three time points separated by two-month intervals. Mindfulness was found to be negatively correlated with burnout, both directly and in an indirect relationship mediated by alexithymic tendencies; mindfulness was also positively and directly associated with self-evaluation of performance, and indirectly positively associated with performance as evaluated by a teammate, via burnout. Structural equation modeling showed that the hypothesized model represented an acceptable fit to the data, based on several indices. Our findings suggest that mindfulness may help to enhance performance and reduce future burnout among athletes. **Keywords:** Sport; Meditation; Emotion; Self-efficacy; Other-rated performance.

Cite this article as:

Amemiya, R., & Sakairi, Y. (2019). The role of mindfulness in performance and mental health among Japanese athletes: An examination of the relationship between alexithymic tendencies, burnout, and performance. *Journal of Human Sport and Exercise*, 14(2), 456-468. doi:<https://doi.org/10.14198/jhse.2019.142.17>

 **Corresponding author.** Faculty of Health and Sport Sciences, University of Tsukuba, 1-1-1, Tennodai, Tsukuba, Ibaraki, 305-8574, Japan. <https://orcid.org/0000-0002-1531-7639>

E-mail: r.amemiya01@gmail.com

Submitted for publication August 2018

Accepted for publication October 2018

Published June 2019 (*in press* November 2018)

JOURNAL OF HUMAN SPORT & EXERCISE ISSN 1988-5202

© Faculty of Education. University of Alicante

doi:10.14198/jhse.2019.142.17

INTRODUCTION

In recent decades, studies of psychological problems among athletes have identified burnout (e.g., Gustafsson et al., 2018), which is defined as “a psychological, emotional, and at times a physical withdrawal from a formerly pursued and enjoyable activity” (Smith, 1986, p.37) as not only a problem for psychological health but also one that leads to reduced performance self-efficacy and actual performance (Gustafsson et al., 2011; Raedeke, 1997). Thus, there is a need to investigate the underlying causes of the onset and progression of burnout among athletes, and to develop effective methods of controlling burnout and impaired performance.

Previous research has reported that multiple factors surrounding individuals are predictors of burnout (e.g., Gustafsson et al., 2011). As a key set of factors among these, individual tendencies such as aspects of personality have been highlighted as predictors of burnout (Gustafsson et al., 2017). In addition, intuition suggests that interpersonal conflict within the organization to which an athlete belongs, such as with their fellow team members, is also a predictor of burnout. According to a study by Isoard-Gautheur et al. (2016), athletes who receive an adequate amount of social support are not prone to burnout, whereas athletes with low levels of social support cannot cope with interpersonal and competitive stress, and as a result, they may score highly for burnout. Therefore, the above-mentioned psychosocial factors may also function as mediating variables between athletes' characteristics and burnout.

Based on previous work by Smith (1986) and Gustafsson et al. (2011) on the process by which burnout symptoms develop, burnout is more than an immediate stress reaction, and is evoked when athletes interpret a stressful situation as threatening or overwhelming; in this case, an emotional response occurs, which is associated with burnout symptoms. As a previous study has mentioned, such interpretations of a situation are also caused by differences in individuals' characteristics (Sherman et al., 2015). Therefore, based on previous research, it can be presumed that burnout in athletes is evoked by multi-dimensional factors, and may be triggered by individual characteristics. Therefore, it is important to clarify which individual traits are predictors of the initial or main symptoms of burnout among athletes, in order to provide effective support in the avoidance of burnout.

In recent years, alexithymic tendencies have been identified in individuals experiencing these sorts of difficulties with emotional awareness and expression, and such tendencies have been shown to be closely related to the onset of burnout (Amemiya and Sakairi, 2015; Pedersen et al., 2016). When alexithymia was first identified, it was treated as a set of personality tendencies characteristic of patients with psychosomatic illnesses. However, in recent decades, alexithymia is increasingly thought of as a cluster of individual characteristics that anyone may exhibit. Therefore, in the present article, the concept of alexithymia as a general tendency of one's personality is denoted by the expression “alexithymic tendencies,” following Gotow and Kodama (2000). Alexithymic tendencies include several problems with emotional control: difficulty in identifying and distinguishing one's own emotions and physical senses, difficulty in describing emotions, lack of imagination, and externally oriented thinking (Taylor et al., 1997). Individuals may have strong alexithymic tendencies as a result of both genetic influence and environmental factors, and those with such tendencies exhibit poor emotion regulation and a poor ability to deal with stress based on emotional and physical sensations (Hamidi et al., 2010; Taylor et al., 1997). Furthermore, they face problems in interpersonal relationships because they have difficulty expressing their own emotions to other people (Kojima et al., 2003). For these reasons, people with high levels of alexithymia easily obtain long-term exposure to several different stressors; as a result, they are prone to burnout, which leads to emotional and interpersonal exhaustion and reduced motivation (e.g., Pedersen et al., 2016).

Prior research on the relationship between burnout and alexithymic tendencies among athletes has shown that those with strong alexithymic tendencies are prone to falling into an over-adapted state without reflecting on their own condition or internal experience; furthermore, they face difficulties in acquiring social support (Amemiya and Sakairi, 2015). These studies have suggested that athletes with strong alexithymic tendencies are thus unable to appropriately manage their psychosocial (and sometimes physical) problems or to obtain support from others, and consequently, they experience burnout. In addition, although positive emotions lead to stronger motivation for one's activities (Saito et al., 2018), it is possible that motivation for training tends to decline in the case of athletes with high levels of alexithymia, because they have difficulty experiencing positive emotions, such as joy, in a sport setting. Therefore, performance self-efficacy should be expected to decline in such individuals, as a result of less training and fewer positive experience, and they can be expected to exhibit higher levels of burnout. Nevertheless, little research has been carried out to examine the relationship between alexithymia and burnout in athletes, and there is no evidence on how best to support athletes with strong alexithymic tendencies in order to prevent burnout.

An approach to therapy that focuses on the body, rather than general psychotherapy that uses verbal communication, is effective for individuals who have poor awareness of their own internal experiences, such as their own emotions and physical sensations (e.g., people with alexithymic tendencies, or the closely related alexisomia; Ikemi and Ikemi, 1986). Recently, programs that utilize physical and psychological techniques to increase mindfulness have been implemented in a wide range of areas to promote participants' awareness of their own physical and psychological sensations, such as emotions and thoughts. Mindfulness refers to a psychological skill that has been defined as "paying attention in a particular way, on purpose, in the present moment, and nonjudgmentally" (Kabat-Zinn, 1994, p4), and "nonjudgmental observation of the ongoing stream of internal and external stimuli as they arise" (Baer, 2003). Mindfulness also refers to psychological programs designed to improve this skill (Sugiura, 2008). According to Tran, Glück, and Nader (2013, p959), the elements that comprise mindfulness are "Self-regulated attention" and a "Orientation to experience." Thus, mindfulness is the ability to objectively observe oneself by focusing on the internal and external experiences occurring in the present moment (emotions, thoughts, and physical sensations) without judgment.

Although the role and efficacy of mindfulness was originally noted in the field of clinical psychology, the benefits of mindfulness and mindfulness programs have recently received attention in the areas of sports psychology, as elements of mindfulness are associated with increased performance and performance self-efficacy among athletes. For example, Gooding and Gardner (2009) observed a positive correlation between scores on a mindfulness questionnaire and free throw success rates in basketball players during matches in Division 1 of the National Collegiate Athletic Association. Furthermore, Blecharz et al. (2014) report that future soccer shot performance can be indirectly predicted by athletes' levels of mindfulness, mediated by self-efficacy. Therefore, it is possible that mindfulness increases athletes' self-efficacy, enhancing their performance as a result.

In order to explain why mindfulness is related to performance self-efficacy, it is necessary to return to the original theory of mindfulness. According to previous research, the concept of mindfulness encompasses two components, one of which is referred to as a non-judgmental attitude (Kabat-Zinn, 1994; Tran et al., 2013). This type of attitude is one undisturbed by internal reactions, such as thoughts and feelings. In the case of athletes, it is possible that such an attitude helps athletes to consider and regulate their own sporting performance without being affected by anxiety or anger during competition. In fact, Gardner and Moore (2007) note that athletes with high levels of mindfulness are able to focus on actions and thoughts relating to their performance without overreacting to their thoughts, emotional responses, physical sensations, or immediate

external stimuli that arise during competition. Furthermore, Kee and Wang (2008) report that mindfulness in athletes is positively associated with flow, the psychological state that produces high levels of concentration on a sporting task during practice or competition. Therefore, it is expected that mindfulness should help athletes to correctly evaluate the state of their own performance without self-criticism, which in turn should enhance their ability to concentrate on movement during play and increase their performance self-efficacy.

In studies of the relationship between athletic performance and mindfulness, the Mindfulness-Acceptance-Commitment Approach and Mindful Sport Performance Enhancement programs have been developed as methods for increasing athletes' mindfulness, and their effects are currently being investigated using both quantitative and qualitative methods. These approaches have been demonstrated to improve actual and objectively-rated performance, and to suppress psychological reactions that are closely related to decreased performance, such as competitive anxiety (Gardner and Moore, 2007; Gross et al., 2016; Kaufman et al., 2009).

Recent studies have also examined the relationship between mindfulness and burnout that arises in relation to competitive activities. For example, cross-sectional examination of the relationship between mindfulness and burnout among athletes has demonstrated that mindfulness is positively correlated with positive emotions and negatively correlated with negative emotions, suggesting that mindfulness directly and indirectly reduces burnout through emotion regulation athletes with high levels of mindfulness have low burnout scores (Gustafsson et al., 2015). In addition, mindfulness training has been reported to promote participants' skills in maintaining awareness of their internal reactions, such as emotions and thoughts. Therefore, it is possible that athletes with high levels of mindfulness are prone to positive experiences and emotions in competitive settings. Alternatively, they can regulate their psychological or physical state, based on their awareness of internal sensations, if they experience negative responses such as anxiety. The resulting positive emotions and self-regulation based on awareness of negative sensations may lead to suppression of burnout. Furthermore, athletes who have a strong sense of self-compassion, which is related to mindfulness, respond in healthier ways to emotionally difficult situations in the course of sporting activities (Reis et al., 2015).

The results of prior research suggest that increasing athletes' mindfulness is effective in improving both their performance and their mental health; however, there have been few examinations of the mechanisms by which such mindfulness programs work. Furthermore, although studies of alexithymia and burnout among athletes are rarely conducted, it is possible that athletes with high levels of alexithymia cannot regulate their own responses to unpleasant experiences effectively, in that they have difficulty maintaining awareness of their own psychological condition, and as a result, burnout is more likely to occur. Therefore, it is necessary to examine the role of mindfulness in the relationship between alexithymic tendencies and burnout among athletes. In order to demonstrate the effects and establish the safety of mindfulness programs, a detailed investigation of these mechanisms is required. Prior research has used cross-sectional techniques; no longitudinal investigation of the relationships among mindfulness, alexithymia, burnout, and performance variables in athletes has yet been carried out. Thus, the purpose of this study was to investigate the relationship between mindfulness and changes in burnout over time among athletes, as well as how this predicts athletes' future alexithymic tendencies, burnout, and performance efficacy, using self-report and objective assessments at three time points.

METHODS

Participants

The target participant group comprised 154 university athletes in Japan. Based on the listwise deletion method, the 125 participants who gave valid responses during all three periods of the longitudinal study were selected (full valid response rate: 59.62%; 74 men, 50 women, 1 unknown gender; average age: 19.84 years, $SD = 1.04$). The members of the target group belonged to one of eight sports clubs representing six different sports (tennis, soft tennis, dance, football, softball, and soccer) at levels ranging from recreational to international. This study was approved by the Research Ethics Committee of the organization with which the first author is affiliated.

Measures

Athlete Mindfulness Questionnaire

The Athlete Mindfulness Questionnaire (AMQ) developed by Amemiya et al. (2015b) was used to measure the athletes' levels of mindfulness. This scale was developed to assess athletes' mindfulness based on the Five Facet Mindfulness Questionnaire (FFMQ; Baer et al., 2006), which was developed to measure mindfulness in everyday life. The questionnaire comprised questions with their content adapted to the setting of athletes' experiences in competition, with 21 items on four subscales: "Acting with awareness," "Describing," "Non-judging," and "Observing and non-reactivity." In the previous study by Amemiya et al. (2015b), its reliability was confirmed by two analyses: computation of Cronbach's α , and a test-retest analysis with a two-week time interval. Furthermore, the results of structural equation modeling showed that the AMQ has good construct validity. Moreover, the prior research confirmed that the criterion validity of the questionnaire was good. Responses were made on a five-point scale from 0 (*Never*) to 4 (*Very often or always true*).

Sport Alexithymia Scale

The Sport Alexithymia Scale (SAS), developed by Amemiya et al. (2015a), was used to measure the alexithymic tendencies of the athletes. This scale measures the alexithymic tendencies of athletes in competition settings, and comprises 12 items on three subscales: "Difficulty identifying one's own feelings while playing," "Difficulty describing one's own feelings toward team members," and "Externally oriented thinking for sports." Its validity and reliability have been verified in prior research. Responses were made on a five-point scale from 1 (*Strongly disagree*) to 5 (*Strongly agree*).

Burnout Scale for University Athletes

The Burnout Scale for University Athletes (BOSA), developed by Amemiya et al. (2013), was used to measure burnout in the athletes. This scale consists of 20 items on four subscales: "Interpersonal exhaustion," "Lack of personal accomplishment," "Emotional exhaustion for athletic practice," and "Devaluation of team activities." This scale was developed in Japan with reference to Raedeck's (1997) definition of burnout, which is used in current research on athletes, and is original in that this questionnaire can assess athletes' levels of exhaustion, which is the key symptom of burnout, from both an emotional and an interpersonal perspective. Its validity and reliability have been verified in prior research. Responses were made on a five-point scale from 1 (*Strongly disagree*) to 5 (*Strongly agree*).

Psychological Performance Efficacy Scale

The Psychological Performance Efficacy Scale (PPES), developed by Arai et al. (2006) to measure self-efficacy regarding athletic performance, was used to measure several performance variables in the athletes. This scale has one item measuring self-efficacy in relation to each of the following attributes: patience,

aggression, desire for self-realization, desire to win, self-control, ability to relax, concentration, confidence, strategy, and cooperation. Its validity and reliability have been verified by prior research. Responses were made on a 11-point scale (0, 10, 20, etc.) ranging from 0 (*Not the case at all*) to 100 (*Always the case*). The total score was used as an indicator of psychological performance self-efficacy. This scale was developed based on the theory of psychological skills training, and each item represents one of the psychological skills needed in a competitive setting. Therefore, self-evaluative responses to this scale can provide a measure of self-efficacy in relation to performance. However, the scale can also be used as an objective evaluation of psychological skills when the respondent evaluates other people, such as their teammates. The scale was used in both ways in the present study, accompanied by different sets of instructions. The instructions for the self-rated PPES stated: "Please circle the one number from the following numbers (0–100) that most closely applies to your thoughts during a match." The instructions for the other-rated PPES asked about practice as well as matches: "Please circle the one number from the following numbers (0–100) that most closely applies to your thoughts about the other person in your pair during a match or practice."

Procedure

The study period comprised three intervals: from November 2015 until the end of December 2015 (referred to as Time 1 below), from January 2016 until the end of February 2016 (Time 2), and from March 2016 until the beginning of May 2016 (Time 3). During each interval, all participants completed all the measures described above. After the experimenter had explained the survey method, athletes from the same team were assigned to pairs, and each member of the pair completed the PPES with respect to his or her own performance (self-rated PPES) and also with respect to the psychological performance skills of the other member of the pair (other-rated PPES). The mutual pair assessment continued at each time point. If one member of the pair left the team, or if the pairing became difficult based on the organization of the team, a new pair was created at that time.

Statistical Analysis

To investigate the relationships between the athletes' levels of mindfulness at Time 1, alexithymic tendencies at Time 2, burnout at Time 3, and performance (both self-assessed and assessed by others) were examined for the 125 valid data sets. A Pearson product-moment correlation coefficient (r) was calculated between each of the variables included in this model, and the model was tested using structural equation modeling, with the GFI, the AGFI, the CFI, and the RMSEA used to indicate model fit. The criteria indicating a good fit were taken to be a GFI, AGFI, and CFI over .90, and RMSEA under .08. Additionally, indirect effects were tested using the bootstrap method (with 1000 resampling iterations); based on previous studies, p values of .05 or less were taken to represent significant direct and indirect paths. The software packages used to carry out these analyses were SPSS 21.0 and Amos 22.0.

RESULTS

Preliminary analyses

A preliminary analysis of the relationship between the variables showed that mindfulness at Time 1 was negatively correlated with alexithymic tendencies at Time 2 ($r = -.61, p < .01, 95\%$ confidence interval (CI) $[-.49, -.71]$) and with burnout at Time 3 ($r = -.39, p < .01, 95\%$ CI $[-.23, -.53]$). Mindfulness at Time 1 was positively correlated with self-rated PPES score ($r = .56, p < .01, 95\%$ CI $[.42, .67]$), but not with other-rated PPES score, at Time 3. Next, a positive correlation was observed between alexithymic tendencies at Time 2 and burnout at Time 3 ($r = .46, p < .01, 95\%$ CI $[.31, .59]$), and a negative correlation was observed between alexithymic tendencies at Time 2 and self-rated PPES score at Time 3 ($r = -.60, p < .01, 95\%$ CI $[-.47, -.70]$). A significant negative correlation was observed between burnout at Time 3 and self-rated PPES score

at Time 3 ($r = -.52, p < .01, 95\% \text{ CI } [-.38, -.64]$) as well as other-rated PPES score at Time 3 ($r = -.23, p < .01, 95\% \text{ CI } [-.05, -.39]$). Finally, a positive correlation was observed between self-rated and other-rated PPES scores at Time 3 ($r = .20, p < .05, 95\% \text{ CI } [.03, .36]$).

Table 1. Descriptive statistics and Pearson correlation coefficient

	1	95%CI	2	95%CI	3	95%CI	4	95%CI	5	95%CI	Mean	SD
1 Mindfulness at Time1	—		-.61	-.71 — -.49 **	-.39	-.53 — -.23 **	.56	.42 — .67 **	.12	-.06 — .29	47.05	14.08
2 Alexithymia at Time2			—		.46	.30 — .59 **	-.60	-.70 — -.47 **	.01	-.17 — .19	30.78	7.46
3 Burnout at Time3					—		-.52	-.64 — -.47 **	-.23	-.39 — -.05 *	48.49	14.50
4 Self-rated Performance Efficacy at Time3							—		.20	.03 — .36 *	69.15	15.09
5 Other-rated Performance Efficacy at Time3									—		74.06	14.47

* $p < .05$, ** $p < .01$

Structural Equation Modeling

Next, a longitudinal analysis of the relationship between mindfulness at Time 1, alexithymic tendencies at Time 2, and burnout and performance at Time 3 was conducted using structural equation modeling. Mindfulness at Time 1 was treated as the independent variable, alexithymic tendencies at Time 2 and burnout at Time 3 as mediating variables, and PPES scores (both self- and other-rated) at Time 3 as the dependent variables. The path from mindfulness at Time 1, via alexithymic tendencies at Time 2, to other-rated PPES score at Time 3 was not significant; when this path was eliminated and the analysis was repeated, fit indices for the model were as follows: $\chi^2 = 30.555, df = 17, p = .023$; GFI = .944; AGFI = .882; CFI = .974; RMSEA = .080; accordingly, this model was confirmed to be a good fit by the criteria outlined above. Standardized regression coefficients (β) indicated that mindfulness at Time 1 was negatively correlated with alexithymic tendencies at Time 2 ($\beta = -0.61, p < .001, 95\% \text{ CI } [-0.51, -0.70]$) and with burnout at Time 3 ($\beta = -0.23, p < .05, 95\% \text{ CI } [-0.05, -0.37]$). Additionally, mindfulness at Time 1 was positively correlated with self-rated PPES score at Time 3 ($\beta = 0.23, p < .01, 95\% \text{ CI } [0.08, 0.39]$), and alexithymic tendencies at Time 2 were positively correlated with burnout at Time 3 ($\beta = 0.31, p < .01, 95\% \text{ CI } [0.06, 0.49]$) and negatively correlated with self-rated PPES scores at Time 3 ($\beta = -0.31, p < .001, 95\% \text{ CI } [-0.16, -0.49]$). Burnout at Time 3 exhibited a direct negative correlation with self-rated PPES score ($\beta = -0.52, p < .001, 95\% \text{ CI } [-0.16, -0.45]$) and other-rated PPES score ($\beta = -.25, p < .01, 95\% \text{ CI } [-.08, -.40]$) at the same time point. Moreover, mindfulness had a negative indirect effect ($p < .01$) on burnout, mediated by alexithymic tendencies, and a positive indirect effect on self-rated PPES score ($p < .01$) mediated by alexithymia and burnout. Mindfulness was further confirmed to have had a positive indirect effect ($p < .01$) on other-rated PPES score via burnout. The coefficient of determination (R^2) for each of the dependent variables in the model was as follows: $R^2 = .38$ for alexithymic tendencies at Time 2, $R^2 = .23$ for burnout at Time 3, $R^2 = .49$ for self-rated PPES score at Time 3, and $R^2 = .06$ for other-rated PPES score at Time 3. This suggests that this model explains between 6% and 49% of the variance in each of the variables (Fig. 2).

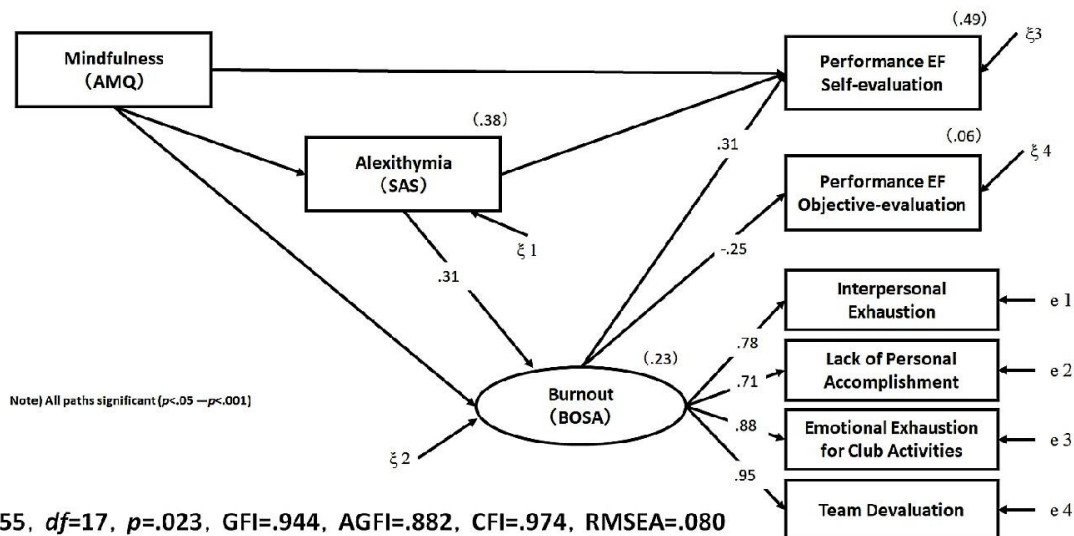

Figure 2. The result of the relationships between mindfulness, alexithymia, burnout, and self-objective performance evaluation in SEM

DISCUSSION

To investigate the mechanisms that relate mindfulness to future burnout and performance, a longitudinal examination of the relationship between burnout and alexithymic tendencies, one factor assumed to underlie this mechanism, was undertaken. The results confirmed that there was a direct negative correlation of the athletes' levels of mindfulness with their alexithymic tendencies two months later and with their burnout scores four months later. Furthermore, an indirect effect was observed, in which mindfulness, mediated by alexithymic tendencies two months later, was negatively associated with burnout scores four months later. Therefore, the longitudinal approach of the present study supports a temporal relationship between mindfulness among athletes and their alexithymic tendencies and burnout scores.

Prior research has suggested that burnout in athletes can be mitigated when positive emotions counteract the negative emotions that function as a source of burnout (Tanaka and Mizuochi, 2013). Accordingly, creating positive emotions in athletes should be effective for the prevention or reduction of burnout (Gustafsson et al., 2015). However, difficulty with emotional awareness and discernment mediates the relationship between alexithymic tendencies and emotional control (Silva et al., 2017). People with these characteristics are prone to behaviors that are influenced by the external environment and stimuli, leading to over-adaptation (Nemiah, 1978). Individuals with strong alexithymic tendencies have a propensity to channel the nervousness evoked by unpleasant emotional experiences into over-adaptation (Taylor et al., 1997). Therefore, athletes with strong alexithymic tendencies may over-adapt to environments without being aware of their own internal sensations, such as emotional and physical exhaustion, resulting in lower motivation for competitive activities and leading to burnout.

The impairments to emotional processing and regulation that may underlie alexithymic tendencies (Taylor et al., 1997) may be reduced by efforts to increase contact with one's emotional experiences or awareness of one's emotions, such as by undergoing cognitive control training (Cameron et al., 2014; Lundblad et al., 2015) or obtaining exposure to emotional experiences and training in experiencing emotions (Lumley, 2004). Simultaneously, methods of increasing mindfulness that enhance people's awareness of their immediate

sensations have been suggested as means of emotional control (Haydicky et al., 2017). Others have proposed mindfulness meditation as a means of increasing regulation of aspects of one's own cognition, including attention, emotion regulation, and self-awareness (Hölzel et al., 2011; Tang et al., 2015). In fact, psychological programs for increasing mindfulness among athletes have been shown to reduce problems with emotional control to a greater extent than traditional support methods (Gross et al., 2016). Because mindfulness has an indirect negative correlation with burnout among athletes, mediated by positive emotions (Gustafsson et al., 2015), attempts to increase those aspects of mindfulness that facilitate cognitive functions such as emotion regulation and self-awareness should result in increased awareness of positive emotions and a reduction in alexithymic tendencies. This, in turn, reduces burnout.

Self-rated PPES scores at Time 3 were directly associated with athletes' mindfulness at Time 1, and there was also an indirect connection between these variables via alexithymic tendencies at Time 2. The functions of emotions include providing input to individuals' choices and cognitive decisions, meaning that they lead to behaviors (Oatley, 1987). Furthermore, as noted by a previous study, strong intrinsic motivation for training can impact performance (Tabassi et al., 2012). Based on prior research and the present findings, it is possible that positive emotions such as pride or joy may increase intrinsic motivation, and motivation allows athletes to commit to practicing, thereby enhancing their performance. Therefore, awareness of one's internal experience of emotions seems to increase motivation for an activity and to promote commitment to practicing in sport; as a result, such awareness leads to high performance and strong performance self-efficacy.

Prior research has reported that strong mindfulness tendencies result in actions based on autonomous motivation (Levesque and Brown, 2007) as well as attitudes that do not attach value judgments (Tran et al., 2013). Thus, athletes with strong mindfulness characteristics should have fewer negative self-assessments of their performance that would lower their self-confidence about their performance. In fact, one prior research proves that conducting four weeks mindfulness training toward athletes reduce their performance anxiety (Thompson et al., 2011). Furthermore, in our present study, the relationship between mindfulness and positive self-evaluation of sporting performance was confirmed. However, there was no significant direct path from mindfulness to other-rated PPES; rather, the relationship between these variables was mediated by burnout four months after the initial mindfulness score was recorded. Previous research has suggested that regulation of mental health affects performance: for example, previous studies suggest that athletes whose psychological state is suboptimal face barriers that have a negative impact on their performance (Gardner and Moore, 2006). Therefore, prior research and the present results thus indicate that strong tendencies to mindfulness contribute to a reduction in mental health problems, such as burnout and alexithymic tendencies, and that well-regulated mental health predicts improvement in sporting performance, as measured by objective as well as subjective performance variables.

The present study confirmed that mindfulness is directly and indirectly related to future burnout and performance efficacy. However, several limitations of the present study should be noted. First, causal relationships between variables were hypothesized and investigated by means of a longitudinal survey method. However, a more rigorous examination of the causal relationships is required: for example, using an experimental design involving trial administration of interventions that increase mindfulness to athletes and evaluation of the effects of such interventions on mental health and performance. Second, although the results showed a positive correlation between mindfulness and performance self-efficacy, this allows for inferences about the relationship between mindfulness and actual performance only to a limited extent. Therefore, further research is required to establish how mindfulness (via self-efficacy) is associated with measures of actual performance, such as running times or shooting scores.

Although these points still remain at issue, the present study found that mindfulness reduced alexithymic tendencies and burnout among athletes, and also promoted performance efficacy. A more multifaceted investigation of the relationship of mindfulness with performance and other psychological characteristics should be carried out on the strength of the present study's findings.

FUNDING

This work was supported by the Japanese Society for Promotion of Science via Grant-in-Aid for JSPS Research Fellow (15J00604).

REFERENCES

- Amemiya, R., & Sakairi, Y. (2015). The Role of Athletes' Mindfulness in Alexithymia and Burnout. *Japanese Journal of Sport Psychology*, 42 (2), 81-92. <https://doi.org/10.4146/jjspopsy.2015-1416>
- Amemiya, R. Ueno, Y., & Shimizu, U. (2013). The study of athletic burnout for university athletes: Development of a new university athletes' burnout scale. *Japanese Journal of Sports Psychiatry*, 10, 51-61, 2013.
- Amemiya, R. Ueno, Y., & Shimizu, U. (2015a). Development of new alexithymia tendency scale for athletes: The relationship between athletes' alexithymia and burnout. *Stress management research*, 11(1), 8-19, 2015.
- Amemiya, R. Yusa, Y., & Sakairi, Y. (2015b). Development of a mindfulness questionnaire for athletes. *Japanese Journal of Cognitive Therapy*, 8(1), 106-115.
- Arai, H. Oba, Y., & Oka, K. (2006). Self-efficacy for psychological performance among university athletes. *Japanese Journal of Test and Measurement in Health and Physical Education*, 6, 31-38, 2006.
- Baer, R. A. (2003). Mindfulness training as a clinical intervention: A conceptual and empirical review. *Clinical psychology: Science and Practice*, 10(2), 125-143. <https://doi.org/10.1093/clipsy.bpg015>
- Baer, R. A., Smith, G. T., Hopkins, J., Krietemeyer, J., & Toney, L. (2006). Using self-report assessment methods to explore facets of mindfulness. *Assessment*, 13(1), 27-45. <https://doi.org/10.1177/1073191105283504>
- Blecharz, J., Luszczynska, A., Scholz, U., Schwarzer, R., Siekanska, M., & Cieslak, R. (2014). Predicting performance and performance satisfaction: Mindfulness and beliefs about the ability to deal with social barriers in sport. *Anxiety, Stress, & Coping*, 27, 270-287. <https://doi.org/10.1080/10615806.2013.839989>
- Cameron, K., Ogrodniczuk, J., & Hadjipavlou, G. (2014). Changes in alexithymia following psychological intervention: A review. *Harvard Review of Psychiatry*, 22(3), 162-178. <https://doi.org/10.1097/HRP.0000000000000036>
- Gardner, F., & Moore, Z. E. (2006). *Clinical sport psychology*. Champaign, IL: Human kinetics.
- Gardner, F. L., & Moore, Z. E. (2007). *The psychology of enhancing human performance: The mindfulness-acceptance-commitment (MAC) approach*. New York, USA: Springer Publishing Company. <https://doi.org/10.1891/9780826103369>
- Gooding, A., & Gardner, F. L. (2009). An investigation of the relationship between mindfulness, pre-shot routine, and basketball free throw percentage. *Journal of Clinical Sport Psychology*, 3(4), 303-319. <https://doi.org/10.1123/jcsp.3.4.303>
- Gotow, K., & Kodama, M. (2000). Alexithymia personality and verbalization of inner experience on dream experience. *Japanese Journal of Counseling Science*, 33, 256-264.
- Gross, M., Moore, Z. E., Gardner, F. L., Wolanin, A. T., Pess, R., & Marks, D. R. (2016). An empirical examination comparing the mindfulness-acceptance-commitment approach and psychological skills

- training for the mental health and sport performance of female student athletes. *International Journal of Sport and Exercise Psychology*, 1-21.
- Gustafsson, H., DeFreese, J. D., & Madigan, D. J. (2017). Athlete burnout: Review and recommendations. *Current Opinion in Psychology*, 16, 109-113. <https://doi.org/10.1016/j.copsyc.2017.05.002>
- Gustafsson, H., Kenttä, G., & Hassmén, P. (2011). Athlete burnout: An integrated model and future research directions. *International Review of Sport and Exercise Psychology*, 4(1), 3-24. <https://doi.org/10.1080/1750984X.2010.541927>
- Gustafsson, H., Madigan, D. J., & Lundkvist, E. (2018). Gustafsson, H., Madigan, D. J., & Lundkvist, E. (2018). Burnout in athletes. In *Handbuch Stress-regulation und Sport* (pp. 489-504). Springer, Berlin, Heidelberg. https://doi.org/10.1007/978-3-662-49322-9_24
- Gustafsson, H., Skoog, T., Davis, P., Kenttä, G., & Haberl, P. (2015). Mindfulness and its relationship with perceived stress, affect, and burnout in elite junior athletes. *Journal of Clinical Sport Psychology*, 9(3), 263-281. <https://doi.org/10.1123/jcsp.2014-0051>
- Hamidi, S., Rostami, R., Farhoodi, F., & Abdolmanafi, A. (2010). A study and comparison of alexithymia among patients with substance use disorder and normal people. *Social and Behavioral Sciences*, 5, 1367-1370. <https://doi.org/10.1016/j.sbspro.2010.07.289>
- Haydicky, J., Wiener, J., & Shecter, C. (2017). Mechanisms of action in concurrent parent-child mindfulness training: A qualitative exploration. *Mindfulness*, 8, 1-18. <https://doi.org/10.1007/s12671-017-0678-1>
- Hölzel, B. K., Lazar, S. W., Gard, T., Schuman-Olivier, Z., Vago, D. R., & Ott, U. (2011). How does mindfulness meditation work? Proposing mechanisms of action from a conceptual and neural perspective. *Perspectives on Psychological Science*, 6(6), 537-559. <https://doi.org/10.1177/1745691611419671>
- Ikemi, Y., & Ikemi, A. (1986). An oriental point of view in psychosomatic medicine. *Psychotherapy and Psychosomatics*, 45, 118-126. <https://doi.org/10.1159/000287937>
- Isoard-Gauthier, S., Trouilloud, D., Gustafsson, H., & Guillet-Descas, E. (2016). Associations between the perceived quality of the coach-athlete relationship and athlete burnout: An examination of the mediating role of achievement goals. *Psychology of Sport and Exercise*, 22, 210-217. <https://doi.org/10.1016/j.psychsport.2015.08.003>
- Kabat-Zinn, J. (1994). *Wherever you go. There you are: Mindfulness meditation in everyday Life*. New York, USA: Hyperion Books.
- Kaufman, K. A., Glass, C. R., & Arnkoff, D. B. (2009). Evaluation of Mindful Sport Performance Enhancement (MSPE): A new approach to promoting flow in athletes. *Journal of Clinical Sports Psychology*, 3, 334-356. <https://doi.org/10.1123/jcsp.3.4.334>
- Kee, Y. H., & Wang, C. J. (2008). Relationships between mindfulness, flow dispositions and mental skills adoption: A cluster analytic approach. *Psychology of Sport and Exercise*, 9(4), 393-411. <https://doi.org/10.1016/j.psychsport.2007.07.001>
- Kojima, M., Senda, Y., Nagaya, T., Tokudome, S., & Furukawa, T. A. (2003). Alexithymia, depression and social support among Japanese workers. *Psychotherapy and Psychosomatics*, 72(6), 307-314. <https://doi.org/10.1159/000073027>
- Levesque, C., & Brown, K. W. (2007). Mindfulness as a moderator of the effect of implicit motivational self-concept on day-to-day behavioral motivation. *Motivation and Emotion*, 31(4), 284-299. <https://doi.org/10.1007/s11031-007-9075-8>
- Lumley, M. A. (2004). Alexithymia, emotional disclosure, and health: A program of research. *Journal of Personality*, 72(6), 1271-1300. <https://doi.org/10.1111/j.1467-6494.2004.00297.x>

- Lundblad, S., Garcia, D., Hansson, B., & Archer, T. (2015). Emotional well-being in anorexia nervosa: Negative affect, sleeping problems, use of mood-enhancing drugs and exercise frequency. *Archives of Depression and Anxiety*, 1(1), 1-5. <https://doi.org/10.17352/2455-5460.000001>
- Nemiah, J. C. (1978). Alexithymia and psychosomatic illness. *Journal of Continuing Education in Psychiatry*, 39, 25-37.
- Oatley, K. (1987). Cognitive science and the understanding of emotions. *Cognition and Emotion*, 1(3), 209-216. <https://doi.org/10.1080/02699938708408048>
- Pedersen, A. F., Sørensen, J. K., Bruun, N. H., Christensen, B., & Vedsted, P. (2016). Risky alcohol use in Danish physicians: Associated with alexithymia and burnout?. *Drug and Alcohol Dependence*, 160, 119-126. <https://doi.org/10.1016/j.drugalcdep.2015.12.038>
- Raedeke, T. D. (1997). Is athlete burnout more than just stress?: A sport commitment perspective. *Journal of Sport and Exercise Psychology*, 19(4), 396-417. <https://doi.org/10.1123/jsep.19.4.396>
- Reis, N. A., Kowalski, K. C., Ferguson, L. J., Sabiston, C. M., Sedgwick, W. A., & Crocker, P. R. (2015). Self-compassion and women athletes' responses to emotionally difficult sport situations: An evaluation of a brief induction. *Psychology of Sport and Exercise*, 16, 18-25. <https://doi.org/10.1016/j.psychsport.2014.08.011>
- Saito, K., Dewaele, J. M., Abe, M., & In'nami, Y. (2018). Motivation, emotion, learning experience and second language comprehensibility development in classroom settings: a cross-sectional and longitudinal study. *Language Learning*. <https://doi.org/10.1111/lang.12297>
- Sherman, R. A., Rauthmann, J. F., Brown, N. A., Serfass, D. G., & Jones, A. B. (2015). The independent effects of personality and situations on real-time expressions of behavior and emotion. *Journal of Personality and Social Psychology*, 109(5), 872-888. <https://doi.org/10.1037/pspp0000036>
- Silva, A. N., Vasco, A. B., & Watson, J. C. (2017). Alexithymia and emotional processing: A mediation model. *Journal of Clinical Psychology*, 73(9), 1196-1205. <https://doi.org/10.1002/jclp.22422>
- Smith, R. E. (1986). Toward a cognitive-affective model of athletic burnout. *Journal of Sport Psychology*, 8(1), 36-50. <https://doi.org/10.1123/jsp.8.1.36>
- Sugiura, Y. (2008). New directions for research of emotion regulation and psychological treatments: Potential benefits of mindfulness construct. *Japanese Journal of Research on Emotions*, 16 (2), 167-177. <https://doi.org/10.4092/jsre.16.167>
- Tabassi, A. A., Ramli, M., & Bakar, A. H. A. (2012). Effects of training and motivation practices on teamwork improvement and task efficiency: The case of construction firms. *International Journal of Project Management*, 30(2), 213-224. <https://doi.org/10.1016/j.ijproman.2011.05.009>
- Tanaka, T., & Mizuochi, F. (2013). Relation of the positive affect in coping with an aggravating burnout tendency in male athletes. *Japanese Journal of Sport Psychology*, 40 (1), 43-57. <https://doi.org/10.4146/jjspopsy.2012-1216>
- Tang, Y. Y., Hölzel, B. K., & Posner, M. I. (2015). The neuroscience of mindfulness meditation. *Nature Reviews Neuroscience*, 16(4), 213-225. <https://doi.org/10.1038/nrn3916>
- Taylor, G. J., Bagby, R. M., & Parker, J. D. A. (1997). Disorders of affect regulation: Alexithymia in medical and psychiatric illness. Cambridge, CA: University Press. <https://doi.org/10.1017/CBO9780511526831>
- Thompson, R. W., Kaufman, K. A., De Petrillo, L. A., Glass, C. R., & Arnkoff, D. B. (2011). One year follow-up of mindful sport performance enhancement (mspe) with archers, golfers, and runners. *Journal of Clinical Sport Psychology*, 5(2), 99-116. <https://doi.org/10.1123/jcsp.5.2.99>
- Tran, U. S., Glück, T. M., & Nader, I. W. (2013). Investigating the five facet mindfulness questionnaire (FFMQ): Construction of a short form and evidence of a two-factor higher order structure of mindfulness. *Journal of Clinical Psychology*, 69(9), 951-965. <https://doi.org/10.1002/jclp.21996>



This work is licensed under a [Attribution-NonCommercial-NoDerivatives 4.0 International](https://creativecommons.org/licenses/by-nc-nd/4.0/) (CC BY-NC-ND 4.0).