



Development of a laser amplification system for the multi-pass Thomson scattering system for GAMMA 10/PDX

| | |
|------------------------------|---|
| 著者 (英) | M. Yoshikawa, J. Kohagura, M. Chikatsu, Y. Shima, M. Sakamoto, Y. Nakashima, N. Ezumi, R. Minami, R. Yasuhara, I. Yamada, H. Funaba, T. Minami, N. Kenmochi |
| journal or publication title | Review of scientific instruments |
| volume | 89 |
| number | 10 |
| page range | 10C102 |
| year | 2018-10 |
| 権利 | This article may be downloaded for personal use only. Any other use requires prior permission of the author and AIP Publishing. The following article appeared in Review of Scientific Instruments 89, 10C102 (2018) and may be found at https://aip.scitation.org/doi/10.1063/1.5032224 |
| URL | http://hdl.handle.net/2241/00154689 |

Development of a laser amplification system for the multi-pass Thomson scattering system for GAMMA 10/PDX

Cite as: Rev. Sci. Instrum. **89**, 10C102 (2018); <https://doi.org/10.1063/1.5032224>

Submitted: 03 April 2018 . Accepted: 07 May 2018 . Published Online: 10 July 2018

M. Yoshikawa, J. Kohagura, M. Chikatsu, Y. Shima, M. Sakamoto, Y. Nakashima, N. Ezumi, R. Minami, R. Yasuhara , I. Yamada , H. Funaba, T. Minami, and N. Kenmochi



View Online



Export Citation



CrossMark

ARTICLES YOU MAY BE INTERESTED IN

[Nd:YAG laser Thomson scattering diagnostics for a laboratory magnetosphere](#)

Review of Scientific Instruments **89**, 10C101 (2018); <https://doi.org/10.1063/1.5037473>

[Observation and evaluation of the alignment of Thomson scattering systems](#)

Review of Scientific Instruments **89**, 10C105 (2018); <https://doi.org/10.1063/1.5038772>

[Helium line ratio spectroscopy for high spatiotemporal resolution plasma edge profile measurements at ASDEX Upgrade \(invited\)](#)

Review of Scientific Instruments **89**, 10D102 (2018); <https://doi.org/10.1063/1.5034446>



Development of a laser amplification system for the multi-pass Thomson scattering system for GAMMA 10/PDX

M. Yoshikawa,^{1,a)} J. Kohagura,¹ M. Chikatsu,¹ Y. Shima,¹ M. Sakamoto,¹ Y. Nakashima,¹ N. Ezumi,¹ R. Minami,¹ R. Yasuhara,² I. Yamada,² H. Funaba,² T. Minami,³ and N. Kenmochi⁴

¹Plasma Research Center, University of Tsukuba, 1-1-1 Tennodai, Tsukuba, Ibaraki 305-8577, Japan

²National Institute for Fusion Science, 322-6 Oroshi-cho, Toki, Gifu 509-5292, Japan

³Institute of Advanced Energy, Kyoto University, Gokasho, Uji, Kyoto 611-0011, Japan

⁴Graduate School of Frontier Sciences, University of Tokyo, Kashiwa, Chiba 277-8561, Japan

(Presented 16 April 2018; received 3 April 2018; accepted 7 May 2018;

published online 10 July 2018)

The multi-pass Thomson scattering (MPTS) system is a useful technique for increasing the Thomson scattering (TS) signal intensities and improving the TS diagnostic time resolution. The MPTS system developed in GAMMA 10/PDX has a polarization-based configuration with an image relaying system. The MPTS system has been constructed for enhancing the Thomson scattered signals for the improvement of measurement accuracy and the megahertz sampling time resolution. However, in the normal MPTS system, the MPTS signal intensities decrease with the pass number because of the damping due to the optical components. Subsequently, we have developed a new MPTS system with the laser amplification system. The laser amplification system can improve the degraded laser power after six passes in the multi-pass system to the initial laser power. For the first time worldwide, we successfully obtained the continued multi-pass signals after the laser amplification system in the gas scattering experiments. *Published by AIP Publishing.* <https://doi.org/10.1063/1.5032224>

I. INTRODUCTION

The Thomson scattering (TS) diagnostics is one of the most reliable diagnostic methods for measuring the electron temperature and density of plasmas.^{1–8} However, the time resolution of TS measurement is limited by the probing laser oscillation frequency. In the high-frequency fluctuation plasma experiments, such as the Alfvén ion cyclotron (AIC) modes, electron cyclotron heating experiments, edge localized mode simulation experiments, and pellet injection experiments, the higher time-resolved TS measurements are required. Multi-pass (MP) TS systems were proposed for increasing both the TS signal intensity and time resolution. The multi-pass Thomson scattering (MPTS) scheme effectively increases the scattering signal intensity from plasmas by the probing laser pulse to be focused multiple times onto the scattering volume. MPTS systems have been developed in several fusion plasma devices.^{9–13} In GAMMA 10/PDX (Potential-control and Divertor-simulator eXperiments), the MPTS system of the polarization-based system with image-relaying optics has been developed.^{14–19} GAMMA 10/PDX is an effectively axisymmetric minimum-B anchored tandem mirror with a thermal barrier at both end mirrors.²⁰ The plasma is created by plasma guns, and it is then heated and sustained using ion cyclotron heating (ICH) systems. In addition to ICH, the electron cyclotron heating is applied to produce the electron and ion confinement potential in the

plug and barrier cells. In the end region, we installed a divertor-simulation experimental module to perform the divertor simulation experiments. In our MPTS system, the MP configuration scheme can be easily implemented by modifying the basic single-pass TS system with the addition of polarization devices, a high-reflection mirror, and lenses for the image relaying of the laser beam. The configuration of the MPTS system in GAMMA 10/PDX can be used to realize perfect coaxial multi-passing on each pass. In GAMMA 10/PDX, a double-pass TS system was constructed, doubling the TS signal intensity, and this improved the resolution of the electron temperature measurements.^{14,15} In LHD, the double-pass TS system, which has the same design as the GAMMA 10/PDX double-pass TS system, was operated.¹⁶ By adding a polarization control device, a polarizer, and a high-reflection mirror to the double-pass TS system, we previously successfully constructed over three passing MPTS systems.^{17–19} We achieved approximately 3.6 times increased TS signals by the first to the sixth passing probing lasers through the plasma in a single laser shot.¹⁷ Moreover, the time-dependent electron temperature measurement every 65 ns was successfully obtained.^{18,19} However, in the normal MPTS system, the MPTS signal intensities decrease with the pass number because of the laser power damping due to the optical components. Subsequently, we have developed a new MPTS system by adding the laser amplification system. The laser amplification system can increase the degraded laser power after it is multi-passed in the normal MP system up to the initial laser power. For the first time worldwide, we successfully obtained the continued MP signals after the laser amplification system in the gas scattering experiments. In laser-aided diagnostic systems, it is the first time that the already used laser beam for plasma diagnostics is used

Note: Paper published as part of the Proceedings of the 22nd Topical Conference on High-Temperature Plasma Diagnostics, San Diego, California, April 2018.

^{a)}Author to whom correspondence should be addressed: yosikawa@prc.tsukuba.ac.jp

after passing through the amplification system. Because the normal laser beam degrades its beam quality, it is highly challenging to use laser-aided plasma diagnostics after injecting the laser amplification system.

We herein present the new MPTS system with the laser amplification system, which can obtain more MPTS signals for the first time. The laser amplification system can improve the degraded laser power after six passes in the MP system up to the initial laser power. We demonstrate the continued MP signals after the laser amplification system in the gas scattering experiments.

II. MPTS SYSTEM WITH AMPLIFICATION SYSTEM

A schematic diagram of the new MP system with the amplification system is shown in Fig. 1. This system is based on the GAMMA 10/PDX-MPTS system, which has been used to successfully observe the electron temperature and density of the GAMMA 10/PDX plasma.^{6,7} A horizontally polarized laser beam from the yttrium-aluminum-garnet (YAG) laser (Continuum, Powerlite 9010, 2 J/pulse, and 10 Hz) is focused onto the plasma center by the first convex lens (CVI, $f = 2229$ mm, $\phi = 50.8$ mm) from the downside port window after passing a short-pass mirror, two Faraday rotators for isolation, two half-wave plates, two polarizers, a Pockels cell (Gooch & Housego, QX1630, aperture of 15 mm), mirrors, and irises. After interacting with the plasma, the laser beam is emitted from the upper-side port window and is collimated by the second convex lens (CVI, $f = 2229$ mm, $\phi = 50.8$ mm). These lenses maintain the laser beam quality during the MP propagation through the image-relaying optical system from the iris to reflection mirror ①. In Fig. 1, the bold red lines with arrows show the first passing laser trajectory. The laser beam is reflected by reflection mirror ① for the second pass and is focused again onto the plasma. The blue lines with arrows show

the second passing laser trajectory in Fig. 1. The Pockels cell switches the polarization of the laser beam from the horizontal to the vertical for the reflected passes during the gate pulse (peak-to-peak of 10 kV and duration of ~ 500 ns). We added the second Pockels cell (FastPulse, CF1043SG-1064, aperture of 16 mm) and polarizer before introducing reflection mirror ② to allow the third laser to pass. The laser light is confined between reflection mirrors ① and ② for the MP propagation when the second Pockels cell is off. For the TS light collection optics, we used an Al:SiO₂-coated spherical mirror with a curvature radius of 1.2 m and a diameter of 0.6 m. The scattered light is collected and reflected by the spherical mirrors, after which it reaches an optical fiber bundle with a cross section of 2 mm \times 7 mm. The scattering angle is 90°. The measurable radial positions are $X = 0, \pm 5, \pm 10, \pm 15,$ and ± 20 cm. Each channel of 6.67-m-long optical fiber bundle is connected to a five-channel polychromator. The fiber aperture is located at approximately 0.873 m away from the spherical mirror. The polychromator is comprised of five relay and collection lenses, five interference filters, and five silicon avalanche photodiodes with preamplifiers. The measured wavelengths of the polychromator are 1059 ± 2 nm (CH. 1), 1055 ± 2 nm (CH. 2), 1050 ± 3 nm (CH. 3), 1040 ± 7 nm (CH. 4), and 1020 ± 14 nm (CH. 5). Four-channel high-speed oscilloscopes (IWATSU, DS5524A) are used to measure four wavelength channels with a bandwidth of 200 MHz and a sampling rate of 1.0 GS/s. The signals are recorded by Windows personal computers using the IWATSU multi-oscilloscope control software (IWATSU, MultiVControl V2.23). The electron temperatures are calculated by the chi-squared method.^{8,19} To increase the degraded MP laser beam power, we newly added the laser amplification system onto the normal MP configuration. We switched on the second Pockels cell to change the laser beam trajectory to the laser amplification system after passing through the polarizer, half-wave plate,

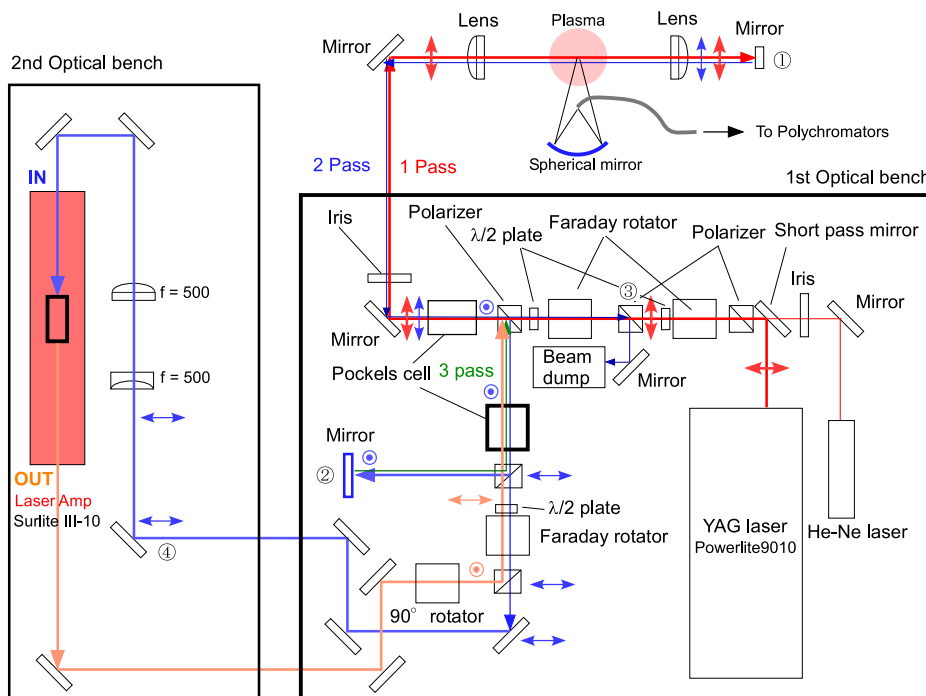

FIG. 1. Schematic diagram of the MPTS system with the amplification system.

Faraday rotator, and mirrors. In the laser amplification system, we set the beam profile adjuster, the amplifier (Continuum, Surelite-III amplifier system), and the 90° rotator. During the switching of the second Pockels cell (peak-to-peak of 10 kV and duration of ~100 ns), the laser amplification system functioned as intended. Subsequently, the amplified laser beam went back to the normal MP system through the polarizer. In Fig. 1, the orange line shows the amplified laser trajectory to the normal MPTS system. We have constructed the new MPTS system with an amplification system.

III. EXPERIMENTAL RESULTS

Initially, we checked the characteristics of the laser amplification system, such as the best timing to inject the laser beam to the amplification system and its increase rate. We directly injected the base laser from the laser beam pass from ③ to ④ shown in Fig. 1 to the amplification system. Figure 2 shows the laser amplification against the delay time after triggering the base YAG laser system, in which the input base YAG laser

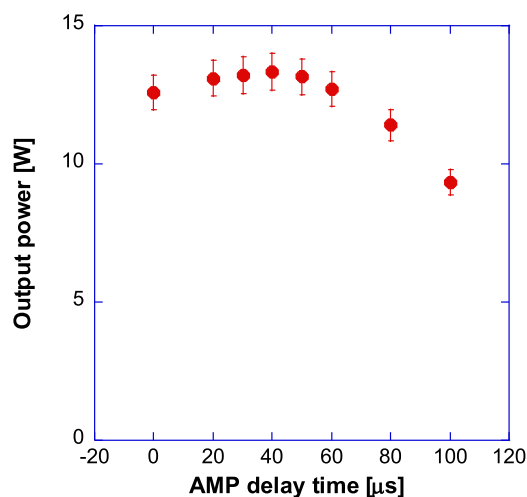

FIG. 2. Laser amplification power against delay time after triggering the base YAG laser.

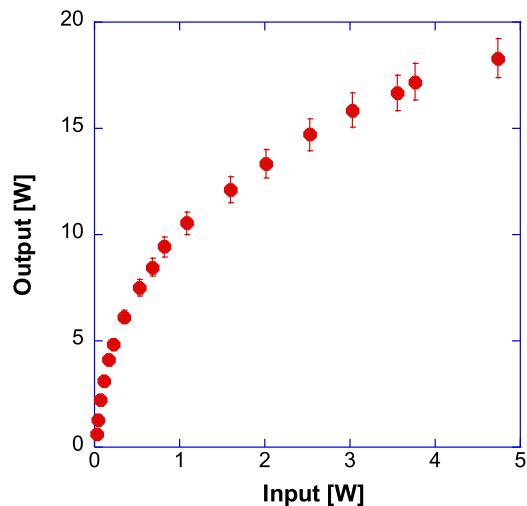

FIG. 3. Laser amplification power against injected laser power at the delay time of 40 μs.

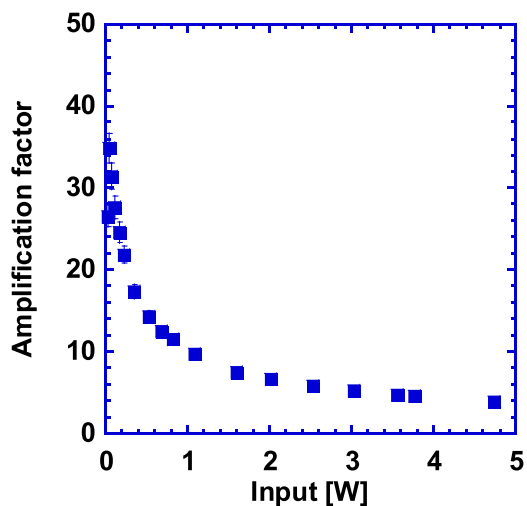

FIG. 4. Laser amplification factor of the laser amplification system.

power was 2.01 W. The maximum output laser power was observed at the delay time of 40 μs after triggering the base YAG laser system. Figure 3 shows the laser amplified output power against the injected laser power at the best laser injection delay timing of 40 μs. The injection laser power of approximately 4 W to the amplification system was increased up to 16 W, which was the initial laser power of approximately 16 W in our typical TS experiments. The power of the laser amplification system could increase up to the initial laser power by a single-pass amplification. Figure 4 shows the laser amplification factor of the laser amplification system. The laser amplification rate is approximately 4 at the input laser power of 4–5 W. It is thought that the laser amplification system is useful for a long-time MP system.

We applied the new MPTS system to the Rayleigh gas scattering experiments. Nitrogen gas of 6.8 kPa is filled in the GAMMA 10/PDX device. Figure 5 shows the measured MP signals with the new MPTS system in the gas scattering experiments. We indicated the MP signal pass numbers and

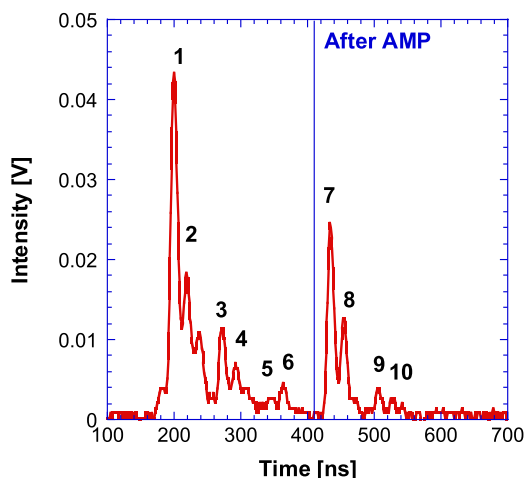

FIG. 5. MP signals with a new MPTS system in the Rayleigh gas scattering experiments. We indicated the pass numbers and the MP signals after injection of the amplification system.

the MP signals after the amplification system. The laser beam after six passes was injected to the amplification system. At this time, the delay time of the amplification system is 100 μ s. The signal intensity at pass seven is lower than that at the first pass. We successfully obtained the MP signals from the 7th to the 10th passes after the amplification system. We successfully constructed the new MPTS system with an amplification system to obtain the long duration of the MP signals.

IV. SUMMARY

We constructed a new MPTS system with an amplification system, which can obtain more MPTS signals. The laser amplification system can improve the degraded laser power after multi-passing in the MP system up to the initial laser power. We successfully obtained the continued MP signals after the laser amplification system in the gas scattering experiments.

ACKNOWLEDGMENTS

The authors thank the members of the GAMMA 10 group of the University of Tsukuba for their collaboration.

This work is performed with the support and under the auspices of the NIFS Collaborative Research Program (Nos. NIFS14KUGM088 and NIFS16KOA035).

- ¹K. Narihara *et al.*, *Fusion Eng. Des.* **34-35**, 67 (1997).
- ²K. Narihara, I. Yamada, H. Hayashi, and K. Yamauchi, *Rev. Sci. Instrum.* **72**, 1122 (2001).
- ³S. Kainaga *et al.*, *Plasma Fusion Res.* **3**, 027 (2008).
- ⁴H. G. Lee *et al.*, *Rev. Sci. Instrum.* **72**, 1425 (2001).
- ⁵A. Mase *et al.*, in *Proceedings of Kyushu International Symposium on Laser-Aided Plasma Diagnostics, 1–3 November 1983* (IOP Publishing, Fukuoka, Japan, 1983), p. 319, KIS-LAPD-83/1p-3.
- ⁶M. Yoshikawa *et al.*, *Plasma Fusion Res.* **6**, 1202095 (2011).
- ⁷M. Yoshikawa *et al.*, *J. Instrum.* **7**, C03003 (2012).
- ⁸J. H. Lee *et al.*, *J. Instrum.* **7**, C02026 (2012).
- ⁹M. Tsalas *et al.*, *J. Instrum.* **7**, C03015 (2012).
- ¹⁰J. Hiratsuka *et al.*, *Plasma Fusion Res.* **5**, 044 (2010).
- ¹¹H. Togashi *et al.*, *Plasma Fusion Res.* **9**, 1202005 (2014).
- ¹²M. Yu Kantor *et al.*, *Plasma Phys. Controlled Fusion* **51**, 055002 (2009).
- ¹³T. Hatae *et al.*, *Rev. Sci. Instrum.* **70**, 772 (1999).
- ¹⁴R. Yasuhara *et al.*, *Rev. Sci. Instrum.* **83**, 10E326 (2012).
- ¹⁵M. Yoshikawa *et al.*, *Rev. Sci. Instrum.* **83**, 10E333 (2012).
- ¹⁶I. Yamada *et al.*, *Rev. Sci. Instrum.* **83**, 10E340 (2012).
- ¹⁷M. Yoshikawa *et al.*, *J. Instrum.* **10**, T08003 (2015).
- ¹⁸M. Yoshikawa *et al.*, *Rev. Sci. Instrum.* **87**, 11D617 (2016).
- ¹⁹K. Ohta *et al.*, *Rev. Sci. Instrum.* **87**, 11E730 (2016).
- ²⁰Y. Nakashima *et al.*, *Nucl. Fusion* **57**, 116033 (2017).